

Programming Procedures:

The correct programming procedure is as follows: Allow the controller to come on as often as possible (except maybe the night before, or morning of, the mowing day). This means the controller is frequently “asking” the moisture sensors if irrigation is needed. It will operate ONLY when the sensors say it is necessary. Set the valve cycle timer (duration/run time) for short cycles. This prevents the runoff you often see with longer cycles. The soil can absorb the water only so fast, and long cycles usually don’t permit all the water to penetrate the soil where it is needed. With the short cycles, you’ll need to have several repeat cycles, or start times, each day. You may want to seek the advice of a professional irrigation consultant to help you set up a program of this type to meet peak consumptive use based on your specific system and plant material.

Since this program can be used year-round (except in freezing climates) with your moisture sensor control, you will eliminate the need for seasonal program adjustments. The sensors will automatically adjust the irrigation to whatever is needed, regardless of the weather. Monitor your system and plant material to fine tune your moisture settings for proper balance and correct plant response.

You can fine tune your settings by:

1. Adjusting the moisture setting for a wetter or dryer control.
2. Changing the programmed cycle duration to prevent excessive runoff.
3. Changing the repeat cycles, or start times, to increase or decrease total irrigation “potential” to meet the peak consumptive use of the turf or plants.

Once you have established a balanced program, further adjustments become less necessary. All you need to do is monitor the results, thus eliminating the constant programming of the controller for seasonal needs.

A free software program is available to assist you in creating the optimum schedule for your landscape. You can download our WaterPerfect program by visiting our website at www.IRROMETER.com, go to “downloads”, select “WaterPerfect”. When prompted, use the word “conserve” for both the user name and password. If you perform an irrigation audit on your landscape, you will have all the data necessary to input into the program, which will then generate a recommended schedule to be programmed into the controller.

Creating a Set Point:

Water Switch default set point is position 3. This should be adjusted to suit your irrigation needs. Rotate dial to desired position. Leave in position for at least 5 seconds. Wait for Long Red LED Flash. This creates set point.

LED Light Interpretation:

RED LED = Allowing Irrigation (Dry)
GREEN LED = Not Allowing Irrigation (Wet)

During Irrigation Runtime:

2 Quick Green LED flashes = Timed Bypass mode
Red and then Green LED Sequence = sensor wire short
Green and then Red LED Sequence = sensor wire open

Timed Bypass:

When the dial is turned to BYPASS, it will switch to allowing irrigation regardless of moisture status for 60 minutes. After it is timed out, then it will operate according to the previously selected preset position, regardless of whether the dial is rotated back. If not turned back to the preset position manually, then next time a BYPASS is needed, the dial will have to be rotated to the preset position until it flashes and then can be turned back to BYPASS for another 60 minutes. This feature avoids having the system uncontrolled by mistake. If BYPASS is needed for an extended period of time, such as plant establishment, the WaterSwitch wiring will need to be temporarily modified to remove power from the module. Without power the module will default to allow irrigation.

Testing Your System:

Set Moisture Control dial to “BYPASS” position. All valves should operate on a manual controller/time clock sequence. Set Moisture Control dial to a “DRY” position. Sensor will override valve (prevent operation) when soil is wet. Set Moisture Control dial in the “WET” range. When soil has been allowed to dry sufficiently, sensor will allow valves to operate on the programmed controller/time clock sequence. Verify soil water status in sensor area with a soil probe.

WARRANTY: The IRROMETER COMPANY warrants its products against defective workmanship or materials under normal use for one year from date of purchase. Defective parts will be replaced at no charge for either labor or parts if returned to the manufacturer during the warranty period. The seller’s or manufacturer’s only obligation shall be to replace the defective part and neither seller nor manufacturer shall be liable for any injury, loss or damage, direct or consequential, arising out of the use of or inability to use the product. This warranty does not protect against abuse, shipping damage, neglect, tampering or vandalism, freezing or other damage whether intentionally or inadvertently caused by the user.

IRROMETER®
1425 Palmyrita Ave., Riverside, CA 92507
951-682-9505 • FAX 951-682-9501
techsupport@irrometer.com
www.IRROMETER.com

(2/21) #725
LITHO U.S.A.

INSTALLATION AND OPERATING INSTRUCTIONS



WS-AC
The WaterSwitch-AC
Automates Conventional
24 VAC Irrigation
Controller/Valves to Water
ONLY when Necessary



The WaterSwitch and Watermark Sensor can be used to control irrigation on individual valves, a group of valves, or all valves on a controller.

WATERMARKSENSORS

The WATERMARK Soil Moisture Sensor should be installed in an active root system area representative of the plant material which is being used as the control point for the individual valve or the Hydrozone area. If used to control an entire controller, select the area of greatest water demand. In selecting the site, factors such as sprinkler distribution, topography, appearance of the turf or plant material and the amount of sun exposure should be considered. It would be preferable to locate the sensor in a drier area, avoiding low spots which may be on the wetter side due to runoff and drainage. Wires from the sensor are run back to the location where the WaterSwitch is mounted.

Step 1 - Soak the WATERMARK sensor in water before the installation. **Always install a “wet” sensor.**

Step 2 - WATERMARK sensor should be in the active root system of the turf or plant being monitored. Therefore, determine the sensor placement based on rooting depth of the plant material.



Typical Installation Depths:

- Cool Season Turf 2" to 5" deep (in root system)
- Warm Season Turf 6" to 8" deep (in root system)
- Shrubs/Ground Cover 8" to 14" deep (in root system)
- Trees 16" to 24" deep (in root system)

Step 3 - Install a splice box (Ametek #182001/2 Econo Box or equal) within 2-3 feet (61-91cm) of the sensor location and cut a trench from the splice box to the sensor location to bury the sensor wire.

NOTE: The sensor wires can be run in conduit if desired. The top of the sensor will socket inside 1/2" (13mm) class 315 PVC or 3/4" (19mm) SDR 11 CPVC pipe, and can be attached with a transition solvent PVC to ABS cement.

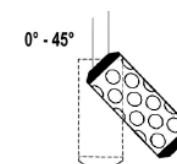

Step 4 - At the end of the trench, excavate a hole to the depth required for the sensor to be installed. Fill the bottom of the hole with a thick slurry made of soil removed from the hole and water, then firmly push the sensor down into the mud

in the bottom of the hole. This will “grout in” the sensor to ensure maximum surface contact between the sensor surface and the surrounding soil. Alternately the sensor can be firmly pushed to the bottom of the access hole as long as it is a tight enough fit to ensure adequate contact; a snug fit is absolutely necessary. A piece of 1/2" PVC pipe (class 315) can be used as an insertion tool to push the sensor in, being careful not to pinch the wires. Be sure the sensors are installed in the active root system of the turf, shrubs or trees. Sensors should be installed vertically or to a 45° downward angle into the soil. For deeper placement, a vertical borehole can be made with a piece of pipe and the sensor inserted to the bottom of the hole, into the thick slurry mixture. Sensor **MUST** be firmly packed in the soil.

Step 5 - Backfill the sensors firmly to ensure a snug fit and run the sensor wires to the splice box. Backfill the sensor wire trench.

Step 6 - Separate the two sensor wires and strip insulation for making the waterproof splices. Then splice the wire to the wires running back to the site where the WaterSwitch is located. Refer to *Sensor Wire Sizing Chart*.

Figure 1

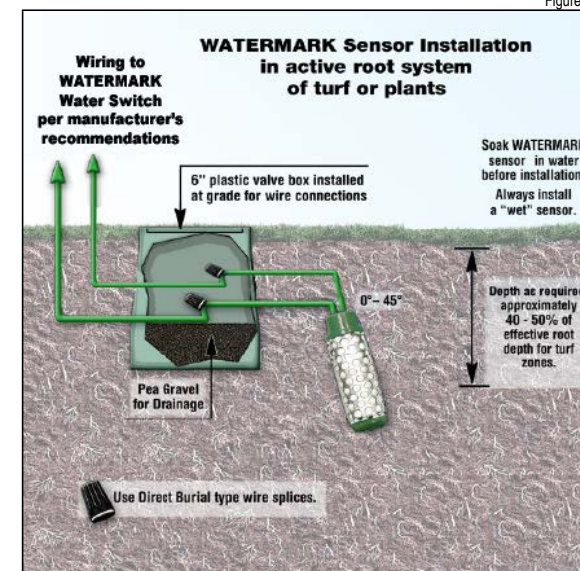

Sensor Wire Sizing Chart

- Up to 1000' #18 AWG-UF Valve Wire
- 1000' to 2000' #16 AWG-UF Valve Wire
- 2000' to 3000' #14 AWG-UF Valve Wire

PLEASE NOTE: Sensors must be installed in the area irrigated by the last valve to run in each valve “group”. Re-sequence valves to accomplish this as necessary. All valves must have the opportunity to irrigate before the area where the sensor is located is watered.

Wiring WaterSwitch directly to Valve(s)

If controlling an individual valve, the WS-AC is best mounted near the valve it is to control and in the area irrigated by that valve. Take care to ensure the module does not become submerged in a flooded valve box. Mounting the WS-AC to the underside of the lid of the valve box or the splice box usually works well. Run wires from the valve(s) being controlled to the WS-AC and make waterproof connections as shown in (Figure 2)

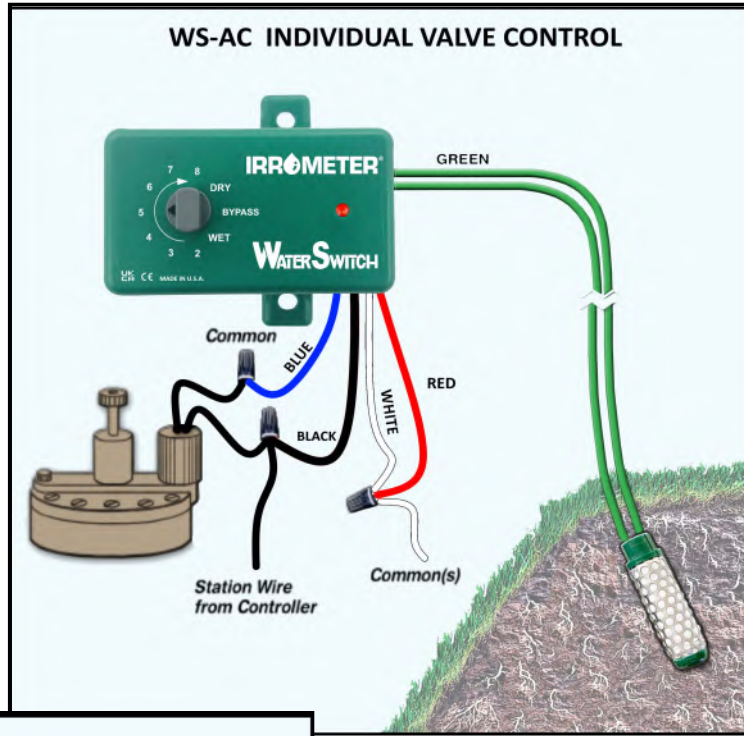
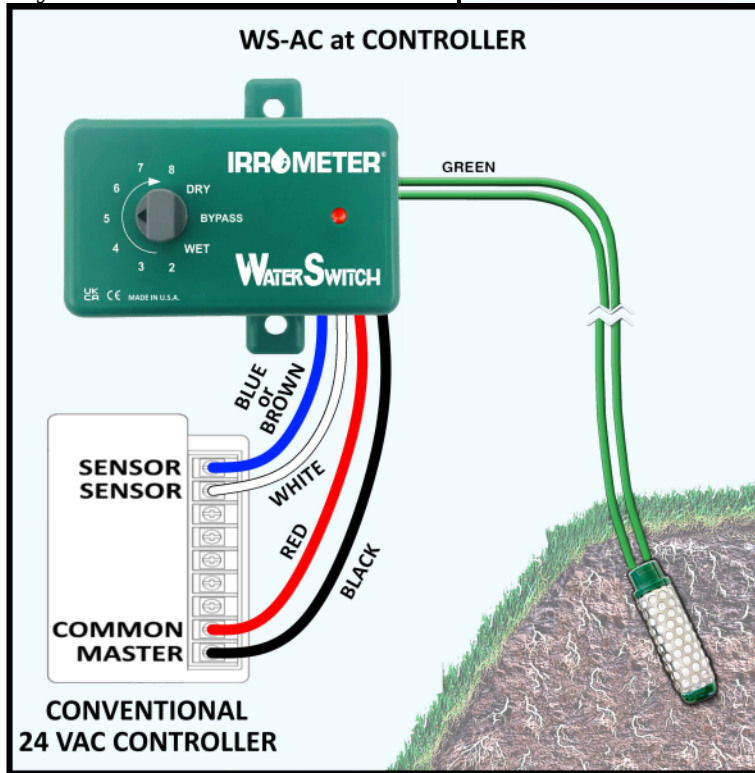

Figure 2

Figure 3



Wiring WaterSwitch to Controller Sensor Input

Attach switch wires to the sensor connections on the controller (may be labeled rain sensor) (Figure 3).

Blue & White = closed switch to irrigate, Brown & White = open switch to irrigate.

NOTE The Water Switch is capable of interfacing with a rainfall or other device by wiring in series to the sensor connections.

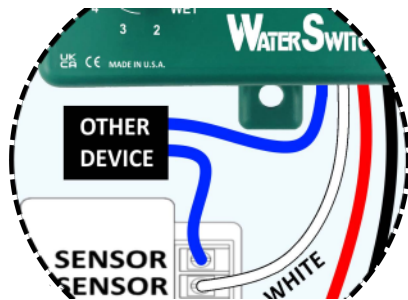

Wiring Multiple WaterSwitches to a Controller

If controlling multiple valves, the WS-AC switches the common of one or more valves and is powered by the master valve circuit. Run wires from the valve(s) being controlled to the WS-AC and make waterproof connections as shown in (Figure 4).

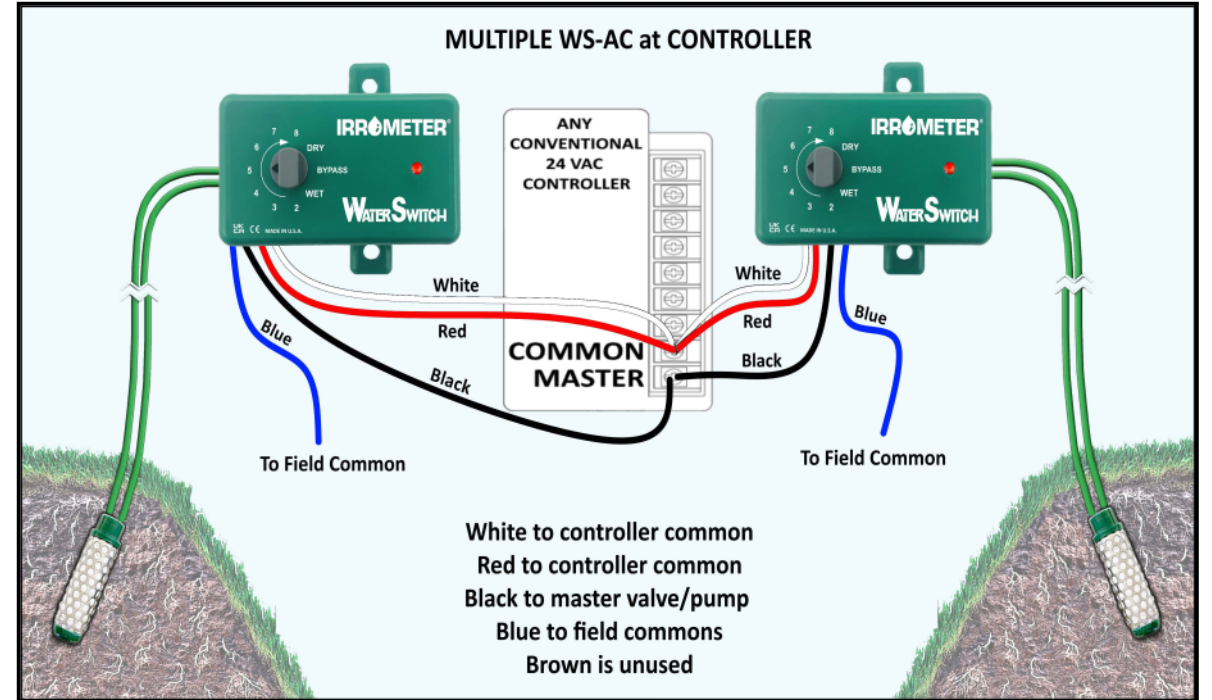

Figure 4

Operation Information

Each valve or group can be set for different soil moisture levels. The WaterSwitch is adjustable from 10 to 85 centibars and has a BYPASS position for temporarily overriding the sensors.

The adjustment dial gives you from very WET(Position#1) to very DRY(Position#9):
 Positions #1 to #4 (approximately 10 centibars to 25 centibars): This is the normal range for most water sensitive turf and shallow rooted plant material.
 Positions #5 to #8 (approximately 35 centibars to 70 centibars): This is the intermediate to drier soil moisture and is useful for most shrubs and ground cover.
 Position #9 (approximately 85 centibars): This is the very dry end of the soil moisture range and should be used with caution. Some deep-rooted, drought tolerant plant material may be able to tolerate this level of dryness.

Keep in mind that the Soil Moisture Sensor only serves to override your irrigation controller/time clock to prevent excessive or unnecessary irrigation and must be watered by the last valve in sequence. The irrigation controller is still "in control" and determines "when" irrigation can occur and "how long" a given valve can run. Thus, the key to successful use of this entire system depends on properly programming your irrigation controller.