

LWS Direct Starter Pump Start

Direct starter for a 1 single phase-electric pump

Specification

model	kW	Hp	Current
Pump Start Pro	0,37-2,2	0,5 - 3	2-18A

Please note that these 'quick start' notes are a summary of key points only, please read the manufactures manual for full information, features and guidelines.



Key Features

Remote Starting of single phase pumps using one of the following:

- 24V AC Signal from irrigation controller master/pump start terminal
- Rollerball Floatswitch (no voltage required)
- Pressure Switch (no voltage required)
- Low Voltage Probes (not included)

Adjustable overload up to 18 amps and 2.2kw (requires adjustment to suit pump)

Dry run protection via float switch terminals

Options

- Bluetooth module & App for setting up
- Large enclosure version
- 3 phase version
- Alarm audio / visual indicator

Dry run Protection - Using Probes

Probes can be used in one of several ways, most common application is to protect a borehole pump from dry running. In any event two probes will be required. To protect the pump from low water level in the borehole, position one probe at the lowest level and the second probe slightly higher at the low level protection level (this is the actual pump protection switch off level).

The common level probe is wired back to COM and the low level probe wired back to MAX.

System is then controlled by irrigation controller, float switch or pressure switch on G/P1

To set delay start when using probes use bottom left trimmer pot which has a white label surrounding it

Fault Finding key

- STEADY green led mains power ON
- FLASHING green led failure or incorrect phase sequence
- Green led OFF device not powered
- STEADY green led electric pump operating
- QUICK FLASHING green led (1 sec) min current control enabled
- Green led OFF pump on standby
- STEADY red led motor temp overload alarm with man reset
- FLASHING red led motor temp overload alarm with auto reset
- STEADY red led motor thermal cut-out trip
- SLOW Flashing red led minimum current alarm
- QUICK FLASHING red led (1 sec) min current control disabled
- AUT button auto mode
- AUT button for alarm reset (when pressed for 2 seconds)
- STEADY green led automatic mode active
- SLOW FLASHING green led motor current cal mode (Min/Max)
- Green led OFF auto mode disabled
- 0 button motor operation stop or standby
- STEADY red led level alarm from sensor input
- FLASHING red led alarm from GA input
- MAN button manual mode

LWS Direct Starter Pump Start

Direct starter for a 1 single phase-electric pump

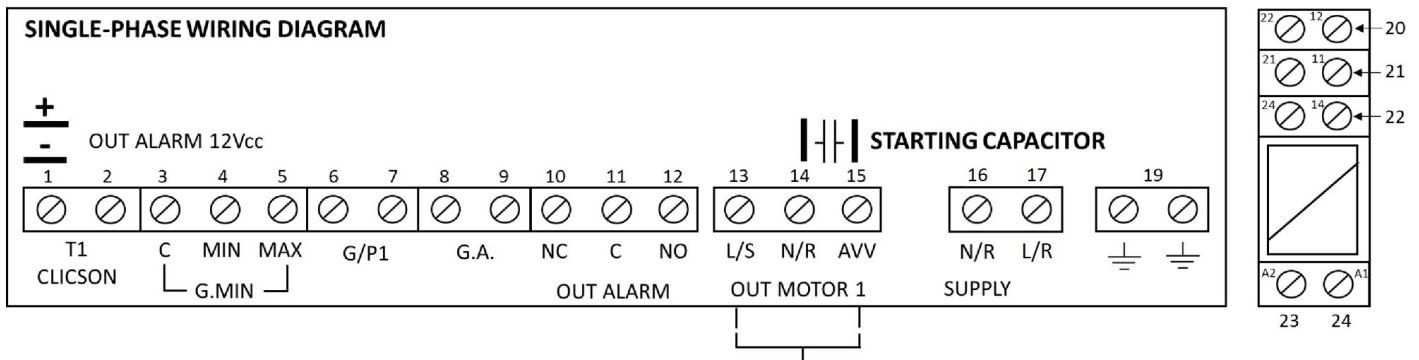

Basic guide to connections

- 1 Leave as found
- 2 Leave as found

- 3 COM Used for probes only (or leave as found)
- 4 Used only for 3 probe operation
- 5 MAX Used for probes only (or leave as found)

If additional float or pressure switch used connect across 3 & 5 (COM & MAX)

If 2 probes used connect across 3 & 5 (COM & MAX) Set timer for re-start - MIN time default

- 6 Connection from additional Pressure Switch or Floatswitch (or leave as found)
- 7 Connection from additional Pressure Switch or Floatswitch (or leave as found)

NB. IF NO IRRIGATION CONTROLLER CONNECTED:

Remove connections at 6 & 7 and use these terminals for the float or pressure switch. All other terminal instructions remain the same. This will also mean terminals 23 & 24 are no longer working.

- 8 Alarm float or switch (volt free)
- 9 Alarm float or switch (volt free)
- 10 NC Alarm Contact (volt free)
- 11 COM Alarm Contact (volt free)
- 12 NO Alarm Contact (volt free)

- 13 Live from pump (for borehole pumps see key on connection drawing) L/S BLACK
- 14 Neutral from pump (for borehole pumps see key on connection drawing) N/R GREY
- 15 AVV Start Winding (if capacitor not in pump – leave empty if 2 wire system) AVV BROWN
Capacitor terminals located above these terminals

- 16 NEUTRAL from Main Supply Input
- 17 LIVE from Main Supply Input
- 18 Not used or not present
- 19 EARTH Pump & SUPPLY Input

- 20 Leave as found
- 21 Leave as found
- 22 Leave as found

- 23 Connection from Common on Irrigation controller (24VAC)
- 24 Connection from Master/Pump start terminal on Irrigation controller (24VAC)
- 25 Connection for pressure switch of floatswitch (zero voltage). Otherwise - leave as found.

MOTOR OUTPUT

- L/S – BLACK
- N/R – GREY
- AVV – BROWN

DEFAULT DIP SWITCH SETTINGS

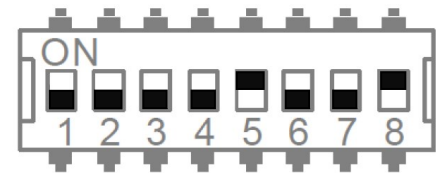

CURRENT AND DELAY SETTINGS - REFER TO MAIN INSTRUCTIONS - SECTION 8