

# 300-PESB Valve

## PESB Performance and Value

TECHNICAL SPECIFICATIONS

### MODEL:



300-PESB Valve

Rain Bird's 3" PESB valve is built tough to offer long life and efficient, trouble-free performance - even under harsh conditions. This valve is designed to withstand extreme pressure surges, effluent water and clogging debris. The PESB model is equipped with a patented scrubber mechanism to actively fight dirt and particles.

### FEATURES:

- Globe and angle configuration for flexibility in design and installation
- Manual internal and external bleed
- External bleed does not allow debris to go through the solenoid ports when system is flushed. Internal bleed operates the valve without allowing water into the valve box; allows pressure regulator to be adjusted without turning the valve on at the controller first
- Slow closing to prevent water hammer and subsequent system damage
- Highly efficient operation with extremely low pressure loss
- Flow control handle adjusts water flows as needed
- Nylon scrubber scrapes its stainless steel screen clean to break down grit and plant material. Prevents debris build-up and clogging

### OPERATING RANGE:

#### Pressure

20 to 200 psi (1.38 to 13.80 bar)

#### Flow with/without PRS-D

60 to 300 gpm (13.62 to 68.10 m<sup>3</sup>/h; 227 to 1136 l/m)

#### Temperature

up to 150°F (66°C)

### OPTIONS (ORDER SEPARATELY):

- Accommodates optional, field-installed PRS-D pressure regulating module to ensure optimum sprinkler performance
- Optional purple flow control handle for non-potable water applications (BPE-NP-HAN)
- Accepts latching solenoid for use with Rain Bird battery-operated controllers up to 150 psi (10.35 bar)
- Compatible with ESP-LXD decoders/IVM

### ELECTRICAL SPECIFICATIONS:

#### Power

24 VAC 50/60 Hz (cycle/sec) solenoid

#### Inrush current

0.41 A (9.84VA) at 60 Hz

#### Holding current

0.28 A (6.72VA) at 60 Hz

### DIMENSIONS:

#### Size

300

#### Height

13 1/4" (34.61 cm)

#### Length

8" (20.32 cm)

#### Width

7" (17.78 cm)

### MODEL:

300PESB 3"

*BSP threads available, specify when ordering.*

### HOW TO SPECIFY:

## 300 - PESB - PRS-D

Size	Model	Optional Feature
300: 3"	PESB: scrubber model	PRS-Dial: pressure regulating module (must be ordered separately)

### Note:

*Valve and PRS-Dial module must be ordered separately. For non-U.S. applications, it is necessary to specify NPT or BSP thread type.*



**SPECIFICATIONS:**

The electric remote control valve shall be a normally closed 24 VAC 50/60 Hz (cycle/sec) solenoid actuated globe/angle pattern design. The valve pressure rating shall not be less than 200 psi (13.80 bar). The valve shall have the following characteristics (circle one):

Flow rate: \_\_\_\_\_ gpm    m<sup>3</sup>/h    l/m

Pressure loss not to exceed: \_\_\_\_\_ psi    bar

The valve body and bonnet shall be heavy-duty glass-filled UV-resistant nylon and have stainless steel bolts. The diaphragm shall be of nylon reinforced nitrile rubber.

The valve shall have both internal and external manual open/close control (internal and external bleed) to manually open and close the valve without electrically energizing the solenoid. The valves internal bleed shall prevent flooding of the valve box.

The solenoid shall require 24 VAC 50/60 Hz power and open with 19.6 VAC minimum at 200 psi (13.80 bar). At 24VAC, average inrush current shall not exceed 0.41 amps. Average holding current shall not exceed 0.28 amps.

The valve shall have a brass flow control stem for accurate manual regulation and/or shut-off of outlet flow. The valve must open or close in less than 1 minute at 200 psi (13.80 bar) and less than 30 seconds at 20 psi (1.38 bar).

The PESB valve shall have a self-cleaning stainless steel screen designed for use in dirty water applications.

The valve construction shall be such as to provide for all internal parts to be removable from the top of the valve without disturbing the valve installation.

**Heavy Duty 3" Remote Control Valve Angle Installation**

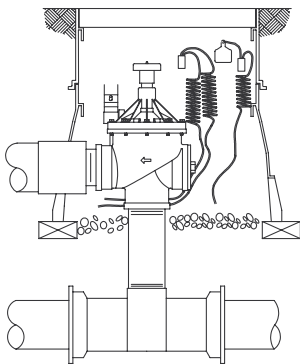

**Heavy Duty 3" Remote Control Valve Globe Installation**

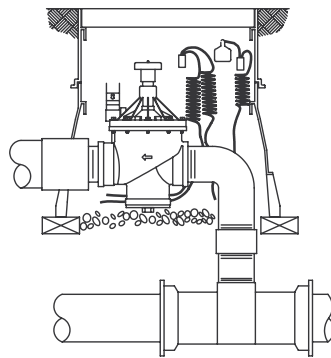

**OPTIONAL FEATURE SPECIFICATION:**

**PRS-D Pressure Regulating Module, 300 PESB-PRS**

When so indicated on the design, the 3" electric remote control valve shall have a pressure regulating module (PRS-D) capable of regulating outlet pressure between 15 and 100 psi (±3 psi) (1.04 and 6.90 bar (±0.21 bar)).

The PRS-D module shall have an adjusting knob for setting pressure and Schrader valve connection for monitoring pressure. The pressure shall be adjustable from the PRS-D when the valve is internally manually bled or electrically activated.

**Non-Potable Flow Control Handle, BPE-NP-HAN**

When so indicated on the design, the valve shall have a purple flow control handle to indicate to the user that non-potable water is being used. There shall be no difference between the black and purple handles except for the color.

PESB 3" Valve Pressure Loss (psi)		
FLOW GPM	GLOBE	ANGLE
60	6.6	6.8
80	5.1	5.9
100	3.2	3.5
120	1.8	1.8
140	1.8	2.1
160	2	2.1
180	2.2	2
200	2.7	2.5
250	4	3.4
300	4.9	4.5

PESB 3" Valve Pressure Loss (bar)			
FLOW m <sup>3</sup> /h	FLOW l/m	GLOBE	ANGLE
13.63	227.12	0.46	0.47
18.17	302.83	0.35	0.41
22.71	378.54	0.22	0.24
27.25	454.25	0.12	0.12
31.80	529.96	0.12	0.14
36.34	605.66	0.14	0.14
40.88	681.37	0.15	0.14
45.42	757.08	0.19	0.17
56.78	946.35	0.28	0.23
68.14	1135.62	0.34	0.31

**Notes**

1. Loss values are with flow control fully open
2. PRS-D module recommended for all flow rates.

**Recommendations**

1. Rain Bird recommends flow rates in the supply line not to exceed 7.5 ft./sec. (2.29 m/s) in order to reduce the effects of water hammer
2. For flows below 5 gpm (1.14 m<sup>3</sup>/h; 19.21 l/m), Rain Bird recommends use of upstream filtration to prevent debris from collecting below the diaphragm.
3. For flows below 10 gpm (2.27 m<sup>3</sup>/h; 37.8 l/m) Rain Bird recommends the flow control stem be turned down two full turns from the fully open position.

**Rain Bird Corporation**

6991 East Southpoint Road  
Tucson, AZ 85756

**Ph:** (520) 741-6100

**F:** (520) 741-6522

**Rain Bird Technical Services**

(800) RAINBIRD (1-800-724-6247)

U.S. & Canada

**Rain Bird Corporation**

970 West Sierra Madre Avenue  
Azusa, CA 91702

**Ph:** (626) 812-3400

**F:** (626) 812-3411

**Specifications Hotline**

800-458-3005

U.S. & Canada

**Rain Bird International, Inc.**

1000 West Sierra Madre Avenue  
Azusa, CA 91702

**Ph:** (626) 963-9311

**F:** (626) 852-7343

**The Intelligent Use of Water™**

www.rainbird.com