

TORO

570Z & 570S SERIES SPRAY AND SHRUB BODIES

**WATER
SMART**

RUGGED – FLEXIBLE – VERSITILE – RELIABLE: Toro® 570Z Series pop-up spray bodies and 570S Series shrub adapters and shrub risers provide a durable, professional-grade solution for residential and commercial contractors to satisfy all new installation and retrofit requirements. In combination with Toro fixed spray and rotating nozzles, 570Z and 570S Series spray and shrub models can be configured in hundreds of combinations and present an unparalleled range of flexibility. Available in bottom-inlet shrub versions and pop-up body heights of 2", 3", 4", 6" and 12" models (side inlet thread options on 6" and 12"). 570Z and 570S Series spray and shrub models are further available with water-saving factory-installed X-Flow® Technology, and/or integrated Pressure Regulating features. Trusted for over 25 years, 570Z and 570S Series spray and shrub models are the ideal choice.

FEATURES & BENEFITS

Zero Flush Wiper Seal & Ratcheting Riser

Wiper Seal helps eliminate flushing on pop-up (allows more sprinklers per zone). Ratcheting Riser for quick and precise arc adjustment on all pop-up models.

X-Flow Technology

X-Flow in-stem flow shut-off technology built into the riser restricts water loss by 99% should the nozzle be removed or damaged. The exclusive X-Flow technology reduces water waste, landscape erosion, and wet hardscape safety concerns. X-Flow also allows for 'dry' nozzle and filter replacement or system maintenance while the system is running.

Pressure Regulator

Built in pressure regulation to a consistent 30 PSI is available on 570Z and 570S shrub models. WaterSense® certified to prevent water waste due to misting and fogging caused by high-pressure environments.

One-Piece Check Valve (570CV)

One-piece check valve prevents low-head drainage on elevation changes of up to 10 feet. Available factory pre-installed or field install.



Effluent
Options
Available



Check
Valve
Options
Available



Enhanced Zero Flush Seal

No Water Wasted at System Start

System start up is a critical time when water waste can occur. The Toro 570Z Series spray head's wiper seal is pressure-activated and prevents flow-by at start up, meaning no water is wasted and more heads can be installed on the same line.

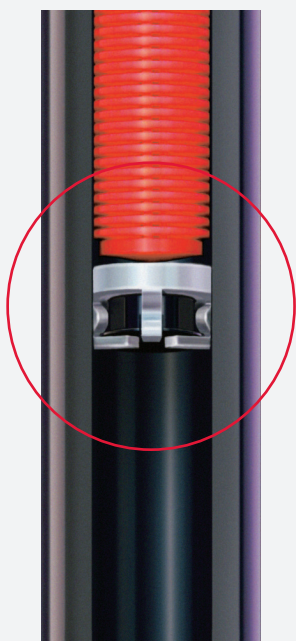

X-Flow® Shut-off Technology

X-Flow® Technology Cuts Off Water Waste

Up to 40 gallons of water per minute can escape through a spray head that has a missing or damaged nozzle. This wasted water can lead to landscape erosion, property damage, or unsafe conditions due to wet hardscapes. X-Flow is factory installed in the riser and holds back over 99% of the water that would otherwise be wasted in cases where the nozzle has been compromised through unintentional accidents or vandalism. Furthermore, X-Flow Technology allows for spray head maintenance or component replacement without the need to turn off the system.



Without X-Flow



With X-Flow

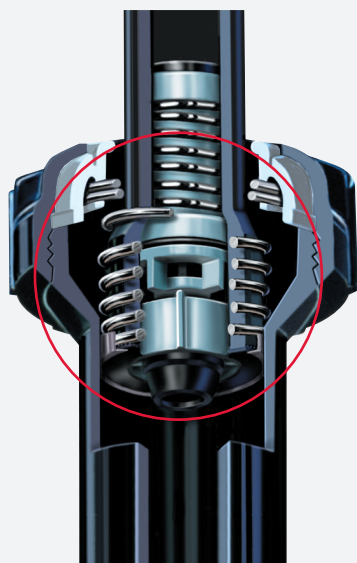

Pressure Regulator

Reliability thanks to Built-in Pressure Regulation

Available for both 570Z (SPRAY) and 570S (SHRUB) models, Toro's factory-installed pressure regulator eliminates water misting and fogging at the nozzle that can lead to rapid evaporation or water being blown away from the intended irrigation area. From the first to the last head, the in-stem pressure regulator provides a steady outlet pressure of 30 PSI and consistent spray head performance across the zone.



Without Pressure Regulation



With Pressure Regulation



570Z & 570ZLP

570S
Shrub Adapter

570Z-2P 2" Spray Head

570Z-2LP 2" Spray Head,
Low Pressure

570Z-3P 3" Spray Head

570Z-3LP 3" Spray Head,
Low Pressure

570Z-4P 4" Spray Head

570Z-4LP 4" Spray Head,
Low Pressure

570Z-6P 6" Spray Head

570Z-6LP 6" Spray Head,
Low Pressure

570Z-6SI 6" Spray Head,
Side Inlet body

570Z-6LPSI 6" Spray Head,
Low Pressure, Side Inlet body

570Z-12P 12" Spray Head

570Z-12LP 12" Spray Head,
Low Pressure

570Z-12SI 12" Spray Head,
Side Inlet body

570Z-12LPSI 12" Spray
Head, Low Pressure, Side
Inlet body

570Z-4P-COM 4" Spray Head
with Check Valve

570Z-6P-COM 6" Spray Head
with Check Valve

570Z-12P-COM 12" Spray Head
with Check Valve



570ZXF

570S-XF
Shrub Riser
with X-Flow

570Z-4P-XF
4" XF Spray Head

570Z-6P-XF
6" XF Spray Head

570Z-6SI-XF
6" XF Spray Head,
Side Inlet Body

570Z-12P-XF
12" XF Spray Head

570Z-12SI-XF
12" XF Spray Head,
Side Inlet Body

570Z-4P-XFCOM
4" XF Spray Head
with Check Valve

570Z-6P-XFCOM
6" XF Spray Head
with Check Valve

570Z-12P-XFCOM
12" XF Spray Head
with Check Valve



570ZPR

570S-PR
PR Shrub Riser

570Z-4P-PR
4" PR Spray Head

570Z-6P-PR
6" PR Spray Head

570Z-12P-PR
12" PR Spray Head

570Z-4P-PRCOM
4" PR Spray Head
with Check Valve

570Z-6P-PRCOM
6" PR Spray Head
with Check Valve

570Z-12P-PRCOM
12" PR Spray Head
with Check Valve



570ZPRX

570S-PRX
PRX Shrub Riser

570Z-4P-PRX
4" PRX Spray Head

570Z-6P-PRX
6" PRX Spray Head

570Z-6SI-PRX
6" PRX Spray Head,
Side Inlet Body

570Z-12P-PRX
12" PRX Spray Head

570Z-12SI-PRX
12" PRX Spray Head,
Side Inlet Body

570Z-4P-PRXCOM
4" PRX Spray Head
with Check Valve

570Z-6P-PRXCOM
6" PRX Spray Head
with Check Valve

570Z-12P-PRXCOM
12" PRX Spray Head
with Check Valve





SPECIFICATIONS

Operational

- Radius: 2 feet to 26 feet
- Operating pressure range: 20-75 psi (15-75 psi for Low Pressure models)
- Recommended operating pressure for spray nozzles: 30 psi
- Recommended operating pressure for rotating nozzles: 45 psi
- Flow rate: 0.5 – 4.5 gpm

Dimensions

- Body diameters:
 - 1 3/8" on 2", 3", 4", 6" and 6" Side Inlet
 - 1 5/8" on 12"
 - 1 3/4" on 12" Side Inlet
- Cap diameter: 2"
- Inlet thread: 1/2" Female
- Side inlet location: 4 3/4" (measured from the top of spray head to center of the side inlet port)

Warranty

- Five years on all models

Additional Features

- ✓ Corrosion-resistant stainless steel retraction spring
- ✓ All models shipped with installed flush plug

Options Available

- ✓ Serviceable Check Valve (570CV) prevents low-head drainage on elevation changes of up to 10 feet (not compatible with Side Inlet or Shrub models)
- ✓ Replacement Zero-Flush seal (570SEAL)
- ✓ Effluent water indicators:
 - Effluent Shrub Adapter (102-1231)
 - Effluent snap-on cap cover (89-9752)
 - Effluent Cap with seal (102-1211)
- ✓ 6" Riser Extender (570-6X)
- ✓ 6" Stationary Riser (570-SR-6) [1/2" male-threaded inlet]
- ✓ 18" Stationary Riser (570-SR-18) [1/2" male-threaded inlet]
- ✓ Riser Pull-up Tool (89-6395)
- ✓ Nozzle Adjustment Key (89-7350)

Pressure Regulating Shrub Risers

Toro 570S Series shrub risers with Pressure Regulation and X-Flow® Technology.

- 570S-XF (Shrub Riser with X-Flow)
- 570S-PR (Shrub Riser with Pressure Regulation)
- 570S-PRX (Shrub Riser with Pressure Regulation and X-Flow)

(Add "E" for Effluent Models)

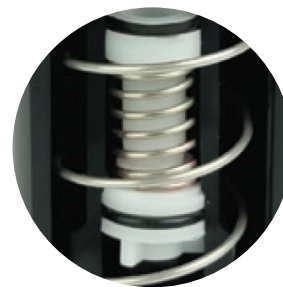

Pressure Regulation



Specifying Information—570Z Series

570X-XXXXX-XXXXXXX					
Base Model	Pop-Up Height	Spring and Inlet	Optional	Optional	Optional
570X	XX	XXX-	XXX	XXX	X
S — Shrub Z — Lawn Pop-up	2 — 2" 3 — 3" 4 — 4" 6 — 6" 12 — 12"	P — Standard LP — Low Pressure SI — Std. Side Inlet* LPSI — Low Pressure SI	XF — X-Flow® Technology PR — Pressure Regulator PRX — Pressure Regulator with XF	COM — Check Valve**	E — Effluent

Example: A 570Z PRX Series Sprinkler with a 6" pop-up height, side inlet would be specified as: **570Z-6SI-PRX**

*Available for 6" and 12" models. **Not compatible with Side Inlet or Shrub models.



www.toro.com

The Toro Company • Irrigation Business • 5825 Jasmine St. • Riverside, CA • 92504 • 877-345-8676

Specifications subject to change without notice. For more information, contact your local Toro distributor. ©2021 The Toro Company. All rights reserved. 21-1021-IRC