

# Keraflo

## Aylesbury KB Valve

### Installation Guide

For valve sizes (DN):

**2" (50) HF**

**2½" (65) SF**

**3" (80) RB**

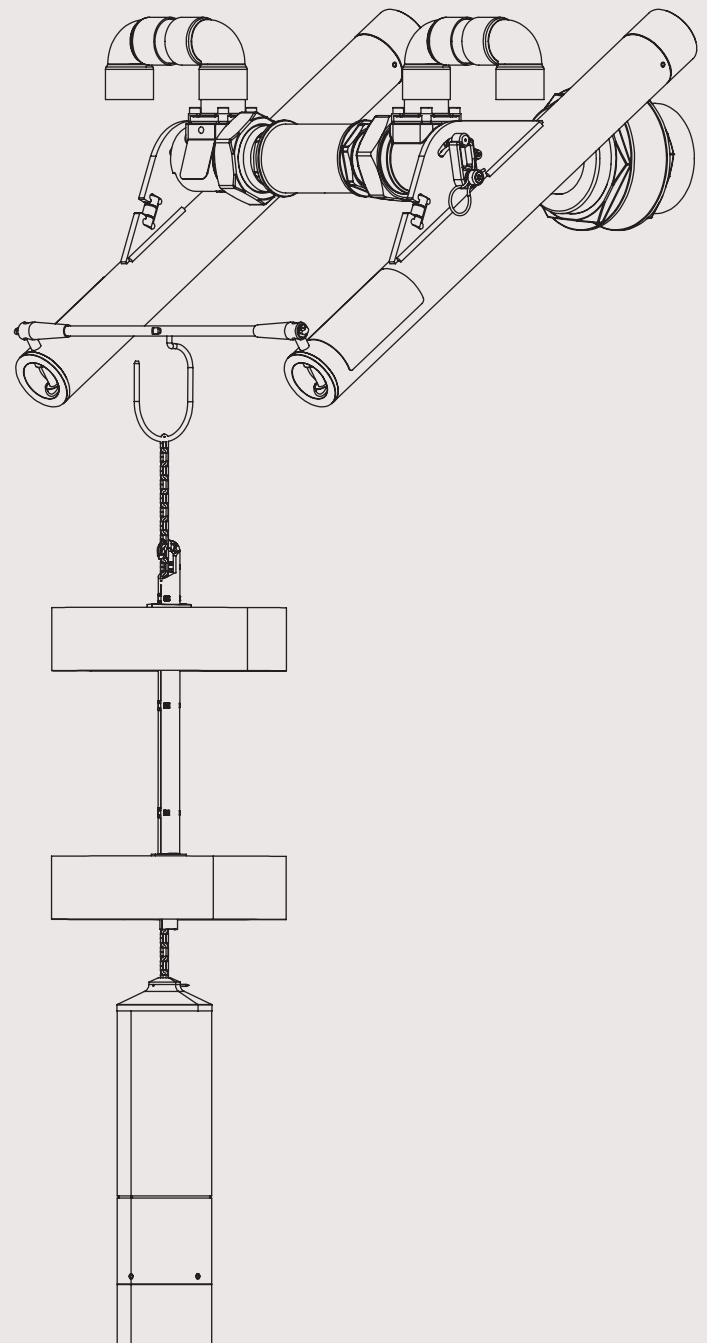

#### **⚠ IMPORTANT**

**Please keep for future reference.**

**Please read these instructions carefully and refer to any diagrams before installation.**

These instructions contain important information which will help you install your **KERAFLO** delayed action float valve correctly and ensure safe use and maintenance.

For further assistance please ring our customer helpline: **0118 921 9920**.

# Keraflo Aylesbury Valves are unlike any other float operated valve, ballcock or float valve.

**KERAFLO** Aylesbury delayed action float valves contain a pair of maintenance free ceramic discs.

## ⚠ IMPORTANT

Please read these instructions carefully and refer to any diagrams before installation.

Installation of valves should be in accordance with the Water Supply (Water Fittings) Regulations 1999 and BS 8558:2015.

Tanks and pipes should be disinfected using the procedures in BS EN 806-4:2010 Section 6: Commissioning.

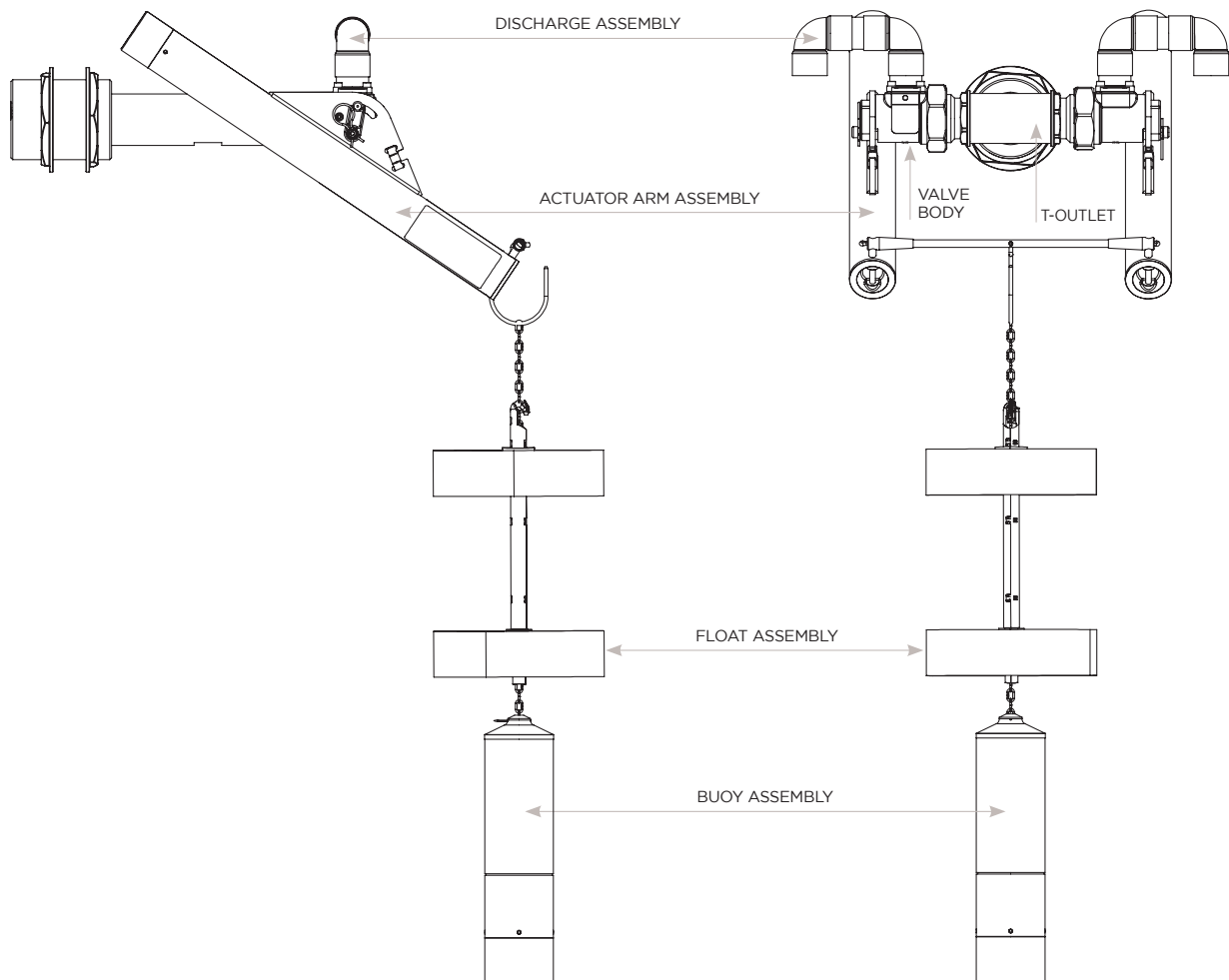

Once the valve has been installed and tested, complete and apply the tank label to the tank and send a photograph of the label in place to [warranties@keraflo.co.uk](mailto:warranties@keraflo.co.uk) in order to receive a full five years' extended warranty for the valve. See warranty sheets for full details.

# Pre-Installation Checks

<b>MINIMUM TANK DEPTH:</b>	A KB Type valve can only be used in a tank that is at least 1.3m deep.								
<b>RAISED VALVE CHAMBERS:</b>	A KB or KAX Type valve can be used in tanks with a raised valve chamber. <b>DO NOT USE A K TYPE VALVE FOR THESE TANKS.</b>								
<b>OPERATING SPACE:</b>	Check for sufficient clearance. The working dimensions are shown on the attached drawings on page 9 & 10.								
<b>OVERFLOW/WARNING PIPES:</b>	Check the position of the overflow and warning pipe (where fitted). See drawing on page 10.								
<b>TURBULENT WATER:</b>	Exceptionally turbulent waters, such as in cooling towers, should be avoided directly beneath the float. Calming measures such as baffle plates, still ponds etc. should be used in these installations.								
<b>FLANGED TANKS:</b>	The design of the valves, allows sufficient clearance between the actuator arm assembly and most internal tank flanges and ribs (see drawing on page 10). The valve backnuts may be adjusted to enable fitting to tanks with large flanges, provided a minimum of 20mm exists between the actuator arm and buoy assembly and the tank wall throughout the arc of the arm.								
<b>ROUND TANKS:</b>	Minimum tank diameters required.								
	<table border="1"> <thead> <tr> <th>VALVE</th> <th>2"HF</th> <th>2½"SF</th> <th>3"RB</th> </tr> </thead> <tbody> <tr> <td>MIN TANK DIAMETER (M)</td> <td>1.8M</td> <td>1.8M</td> <td>1.8M</td> </tr> </tbody> </table>	VALVE	2"HF	2½"SF	3"RB	MIN TANK DIAMETER (M)	1.8M	1.8M	1.8M
VALVE	2"HF	2½"SF	3"RB						
MIN TANK DIAMETER (M)	1.8M	1.8M	1.8M						
	<b>NOTE: TO ENSURE SUFFICIENT OPERATING CLEARANCE IT MAY BE NECESSARY TO EXTEND THE PIPEWORK TO POSITION THE VALVE ASSEMBLY IN THE CENTRE OF THE TANK CHAMBER.</b>								
<b>SLOPING TANK WALL:</b>	The wall to which the Aylesbury KB Valve is to be attached must be vertical. If the wall around the fixing hole is sloped, tapered washers must be used. These should be available from the tank supplier.								
<b>PIPEWORK SUPPORT:</b>	<b>KERAFLO</b> Aylesbury valves create minimal tank wall stress. It is therefore not necessary to provide additional support to the pipework as long as the Code of Practice for the Support of Pipework is met.								
<b>ISOLATING VALVE:</b>	An isolating valve must be fitted as near as is reasonably practicable to the <b>KERAFLO</b> valve.								

# Installation Instructions

The valve is supplied with the actuator arm and discharge assemblies detached. To avoid damage it is recommended, for most installations, to fit both of these assemblies **AFTER** installing the valve in the tank.

- 1** Before fitting the valve, flush the supply pipes to clear all debris.
- 2** Remove and retain the double-R clips and actuator levers from both bodies.
- 3** Remove and retain the backnut closest to the end of the tail.
- 4** Insert the valve tail through the hole in the tank wall observing the side of the T-outlet marked "TOP". The outlet for fitting the discharge should be uppermost.
- 5** Replace the backnut with the flanged side against the tank wall (Diagram 2).
- 6** Connect the supply pipe, then hand tighten the backnut to hold the valve in place.
- 7** To prevent the valve assemblies from turning when tightening the pipe fitting, use either a wrench or a spanner on the valve tail where indicated in Diagram 2.

**DO NOT USE A WRENCH ON ANY OTHER VALVE. THE VALVE ASSEMBLY MUST BE POSITIONED ABSOLUTELY HORIZONTALLY.**

## ⚠ WARNING!

The built-in spirit level must be used to align this valve. Failure to follow the procedure listed below will prevent the valve operating correctly.

Installation of valves should be in accordance with the Water Supply (Water Fittings) Regulations 1999 and BS 8558:2015.

Tanks and pipes should be disinfected using the procedures in BS EN 806-4:2010 Section 6: Commissioning.

DIAGRAM 1

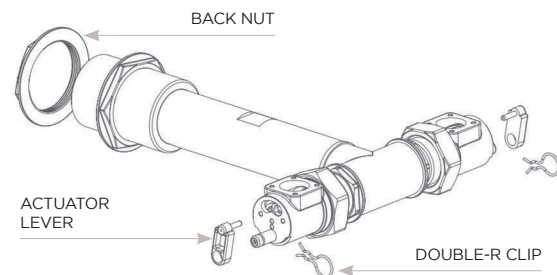
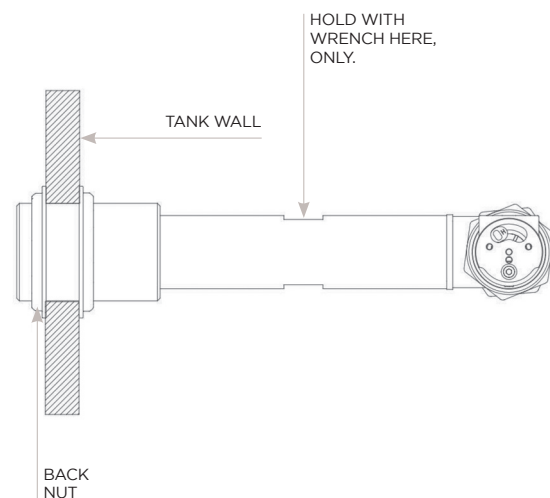

DIAGRAM 2



**8** Level the two valves on the T-outlet by placing a spirit level across the T-outlet, parallel to the tank wall on which it is mounted and twisting the whole assembly to bring the valves level.



**9** Fit the actuator arms over the spigots and push their pins through their respective brackets and into the hole in the actuator located within the valve body (Diagram 3).

**THE ACTUATOR TUBE WITH THE RED DOT SHOULD BE FITTED TO THE VALVE WITH THE RED DOT.**

**THE CAP SCREW HEADS ON THE ACTUATOR ARM BRACKETS SHOULD FACE AWAY FROM THE VALVE ASSEMBLY.**

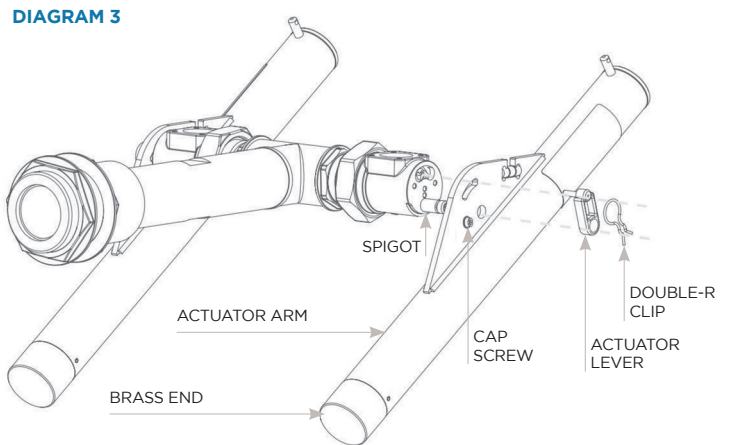

**10** Refit the actuator levers and double-R clips on the spigots (Diagram 3).

**11** The actuator tube should be tilting down towards the tank wall (brass end lowest) as Diagram 3. **NOTE: NEITHER THE LINK TUBE ASSEMBLY NOR THE CHAIN SHOULD BE CONNECTED AT THIS STAGE.**

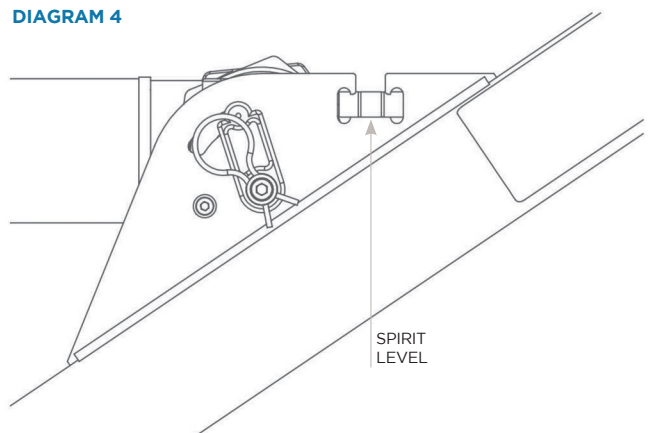

**12** The spirit levels should indicate that the valves are level. The bubble must be **EXACTLY** between the black lines.

**13** If the valves are not level, each individual valve can be rotated at its screwed connection into the T-outlet. This joint is sealed by an “o”-ring so can be moved without fear of a leak.

**14** Loosen the locknut at the T-outlet, as indicated in Diagram 5, and rotate each valve until the bubble in the spirit level is precisely between the black lines.

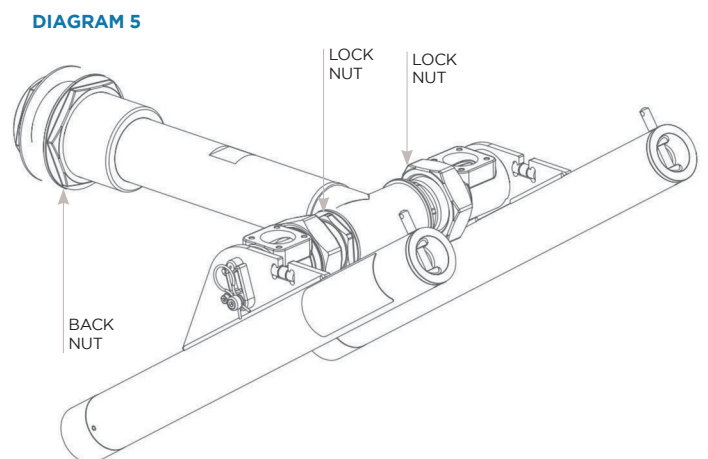

- 15** Align each valve, tighten the locknuts, and re-check the alignment.
- 16** When the clearance and the levels are correctly set, fully tighten the backnuts holding the assembly to the tank wall.
- 17** One end of the link tube assembly is already fitted to the stud of one actuator tube.
- 18** Locate the other end of the link tube assembly over the other actuator stud before inserting and deforming the split cotter pin, to hold link tube assembly in place.  
**NOTE: TO AVOID STRAINING THE LINK TUBE ASSEMBLY DURING INSTALLATION, PUSH THE END OF THE ACTUATOR TUBE DOWN.**
- 19** Hang the chain on the hanger. **DO NOT CUT OR REMOVE ANY PART OF THE CHAIN; IT IS CRITICAL TO THE CORRECT OPERATION OF THE VALVE.**
- 20** The length of this chain determines the opening water level and the position of the float on the chain determines the closing level and the delay.
- 21** Using the 4mm Allen key supplied, fit the discharge assembly referring to Diagram 7 for the direction.
- 22** **CLOSING WATER LEVEL (TWL)**  
 When the actuator tube is held horizontal, the closing water level is indicated by the base of the closing float. Identify the desired maximum water level and measure the distance from the centre line of the valve; this is X.

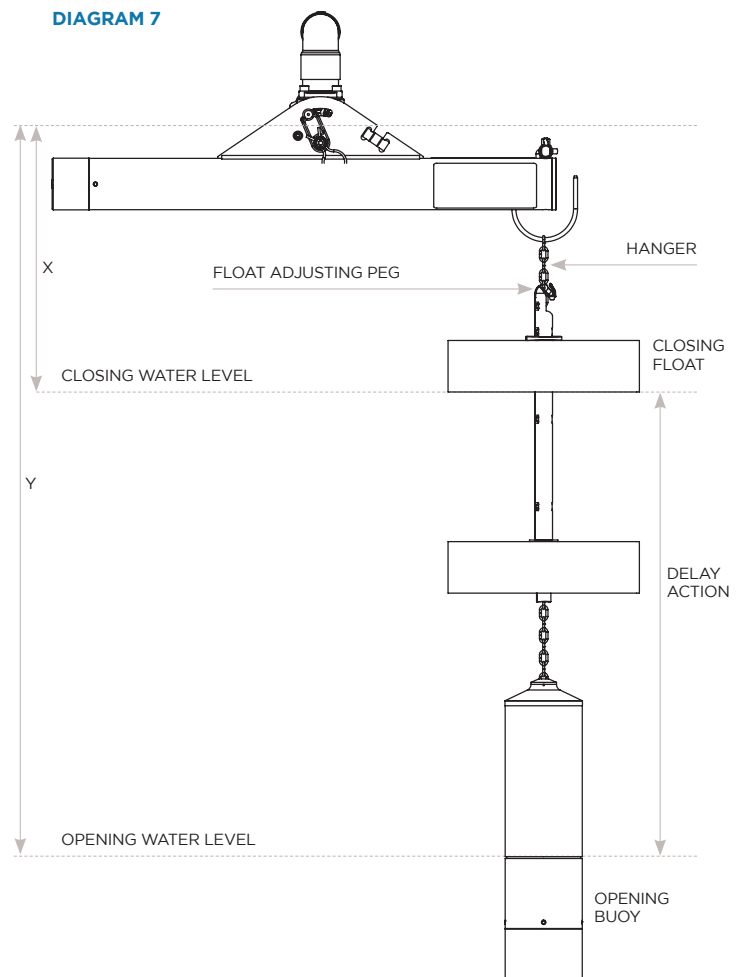
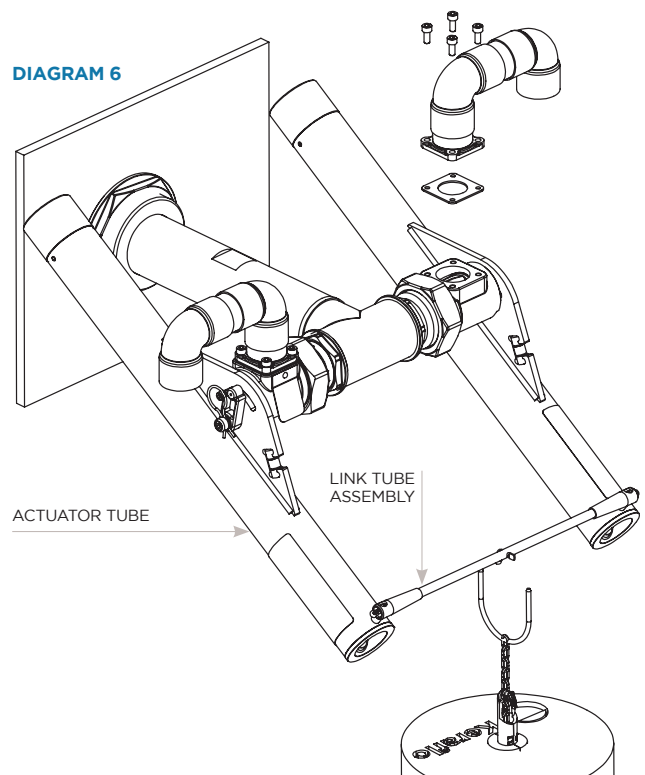

**23** **OPENING WATER LEVEL (LWL)**  
When the actuator tube is held horizontal, the opening water level is indicated by a line on the opening buoy. Identify the desired minimum water level and measure the distance from the centre line of the valve; this is Y.

**24** Adjust the length of the chain from the buoy to the hanger to match the following:

**Chain length = Y - 274mm**

Do not cut the chain, loop any excess chain on to the hanger.

**25** Unhook the Float Adjusting Peg and move the float along the chain so the distance from the Hanger to the Float Peg is as follows:

**X - 190mm**

**26** The highest closing water level (X = 210) can be achieved by having no spare chain links between the hanger and the float adjusting peg. The lowest closing water level (X = 1610) can be achieved by having the float touching the top of the opening buoy whilst using all of the available chain (last link on hanger).

**27** Applications where the top water level (TWL) can rise after the valve has closed will cause the chain to become slack. A cable tie/ratchet strap should be fitted over the float adjusting peg in such a way as to prevent the chain from slipping off. Ensure the chain cannot become entangled with tank tie bars etc.

**IT MAY BE EASIER TO ADJUST THE CHAIN LENGTH BEFORE INSTALLATION.**

## Testing

Before leaving the installation, manually move the valves to test operation a number of times, ensuring that they move freely from the open to the closed position and from the closed to the open position.

Where a valve has not been in operation for one month it is also recommended that the above procedure is carried out.

**28 DELAYED ACTION (LEVEL DIFFERENTIAL)**

The delayed action is the distance the water level will drop from before the valve opens i.e. the difference between opening and closing water levels. This is adjustable between 390mm (Float touching top of Opening Buoy) and 1815mm (Float Adjusting Peg almost touching Hanger whilst using all of the available chain); see page 10.

**⚠ ALIGNMENT WARNING!**

The Actuator Arms must be fitted in the tilted position when the valves are fully closed and the spirit level aligned. This is critical to the operation of the valves.



Once the valve has been installed and tested, complete and apply the tank label to the tank and send a photograph of the label in place to [warranties@keraflo.co.uk](mailto:warranties@keraflo.co.uk) in order to receive a full five years' extended warranty for the valve. See warranty sheets for full details.



# Sizes (DN):

2”(50)HF 2½”(65)SF 3”(80)RB

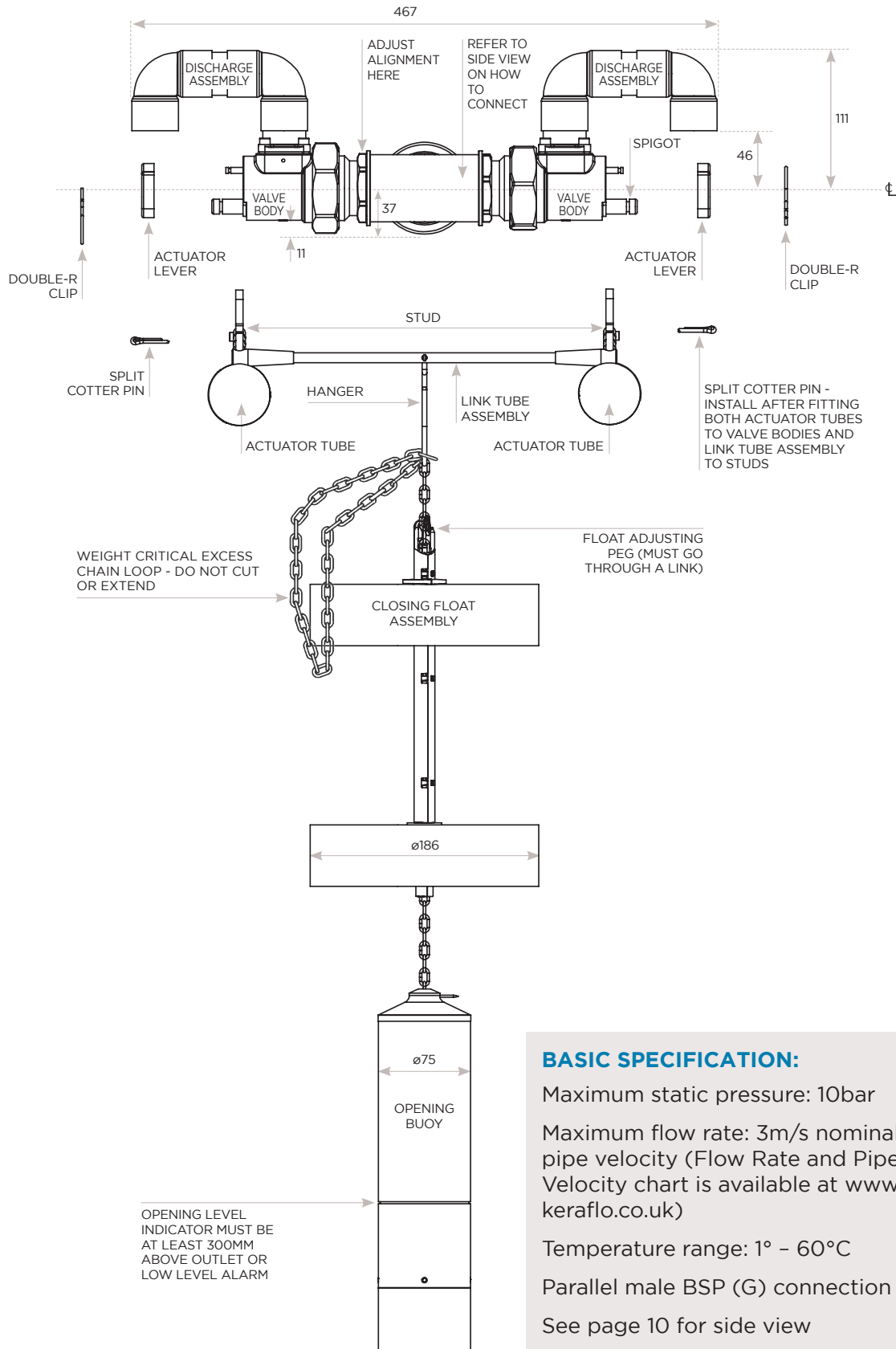

## BASIC SPECIFICATION:

Maximum static pressure: 10bar

Maximum flow rate: 3m/s nominal pipe velocity (Flow Rate and Pipe Velocity chart is available at [www.keraflo.co.uk](http://www.keraflo.co.uk))

Temperature range: 1° - 60°C

Parallel male BSP (G) connection

See page 10 for side view

# Sizes (DN):

- 2”(50)HF**
- 2½”(65)SF**
- 3”(80)RB**

## ⚠ WARNING!

The Warning Pipe and Overflow Outlet should be available above the highest water level achieved before the valve closes.

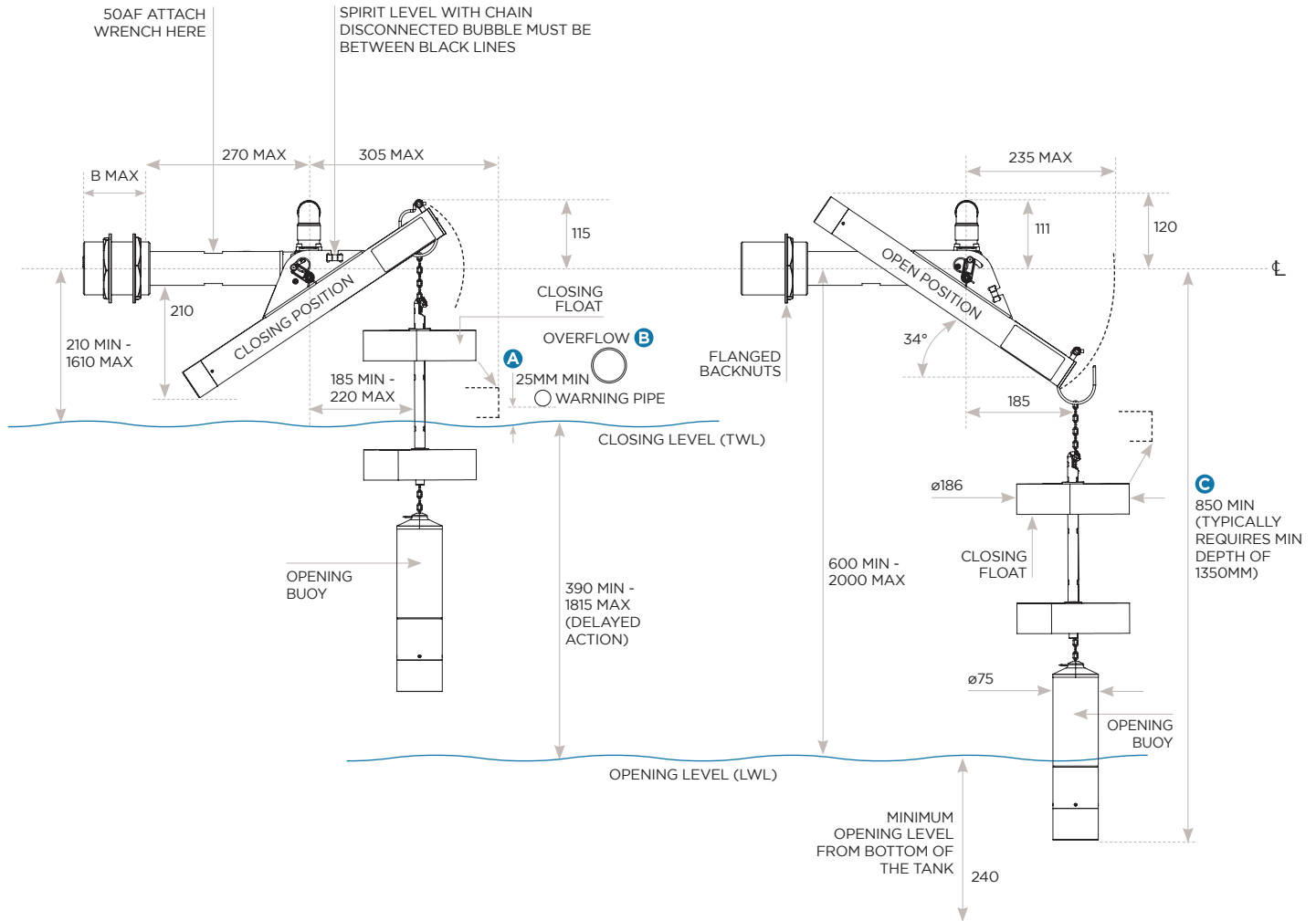

DN	50HF	65SF	80RB
SIZE	2”HF	2½”SF	3”RB
B MAX	95	100	99
ØE	60	75.5	89

### NOTES:

- A** SCHD2, G16.4 Water Regs. Gaps should be more if water is turbulent - especially if near valve discharge.
- B** Typically twice inlet bore. SCHD2, G16.4 Water Regs. Warning/overflow pipes should be capable of taking any possible flow in the pipe arising from inlet valve failure.
- C** When opening level - 575mm  
See page 9 for front view.

# Notes

Lined area for notes, consisting of multiple horizontal dotted lines.



Unit 1  
Woodley Park Estate  
59-69 Reading Road  
Woodley, Berkshire RG5 3AN

0118 921 9920 | [info@keraflo.co.uk](mailto:info@keraflo.co.uk) | [www.keraflo.co.uk](http://www.keraflo.co.uk)



*There are rare occasions when it may be necessary to partially disassemble the valve, for example, to clear a blockage or to replace some parts.*

*If the problem you are experiencing cannot be solved by using a spares kit contact **KERAFLO** or your supplier.*

