

**COLD WATER
STORAGE CONTROL**



Keraflo
OUR WORLD IS WATER

AYLESBURY™

DELAYED ACTION FLOAT-ACTIVATED VALVES



Keraflo have been manufacturing top quality, delayed action float valves in the UK for over 30 years. The Aylesbury™ range is synonymous with mechanical float valve excellence, with tens of thousands of products in continuous use in demanding domestic, commercial and industrial applications throughout the UK and around the world.

The Aylesbury™ Delayed Action Float Valve Range

Aylesbury valves are designed to provide an accurate and efficient method of controlling the level of stored cold water in tanks with and without raised float valve chambers. All Keraflo valves are manufactured under Quality Management Systems certified to ISO.9001:2015 and designed to operate for long periods of time without maintenance. All valves come with a one year warranty which can be extended to five years at no cost.

The valves are easy to install with an 'up and over' discharge arrangement which assists in facilitating Type AA, AB, AF, or AG air gap requirements under the Water Regulations.

The Aylesbury range is ideal for pumped systems because the open to closed 'on/off' valve operation avoids pump hunting and water hammer. The selected water level is unaffected by pressure fluctuation and the patented ceramic disc sealing mechanism means that there is no seat or washer to wear.



The Aylesbury Delayed Action Float Valve Range

Non adjustable opening / closing operating differential of approximately 75mm.

K Type Page 4
KAX Type Page 5

Fully variable opening and closing operating differential of up to 1,820mm and longer on request.

KB Type Page 6
KP Type Page 8

Benefits of Keraflo Aylesbury Valves

Maintenance Free:

Designed to operate for long periods without maintenance.

Backsiphonage Protection:

'Up and Over discharge' to BS1212 Part 2 - helps to facilitate air gap compliance.

Virtually Indestructible:

The heart of the valve incorporates pressure compensated rotating ceramic discs which are aligned in the open position.

Extended Durability:

Non-wearing ceramic disc seal in a DZR brass housing.

Reduces Tank Wall Stress:

The Aylesbury valve's radical design reduces stress on the tank wall fixing point.

Revolutionary Shaped Puncture Proof Float:

Made from polyethylene closed cell foam which is CFC-free, air retardant and chemically and biologically inert.

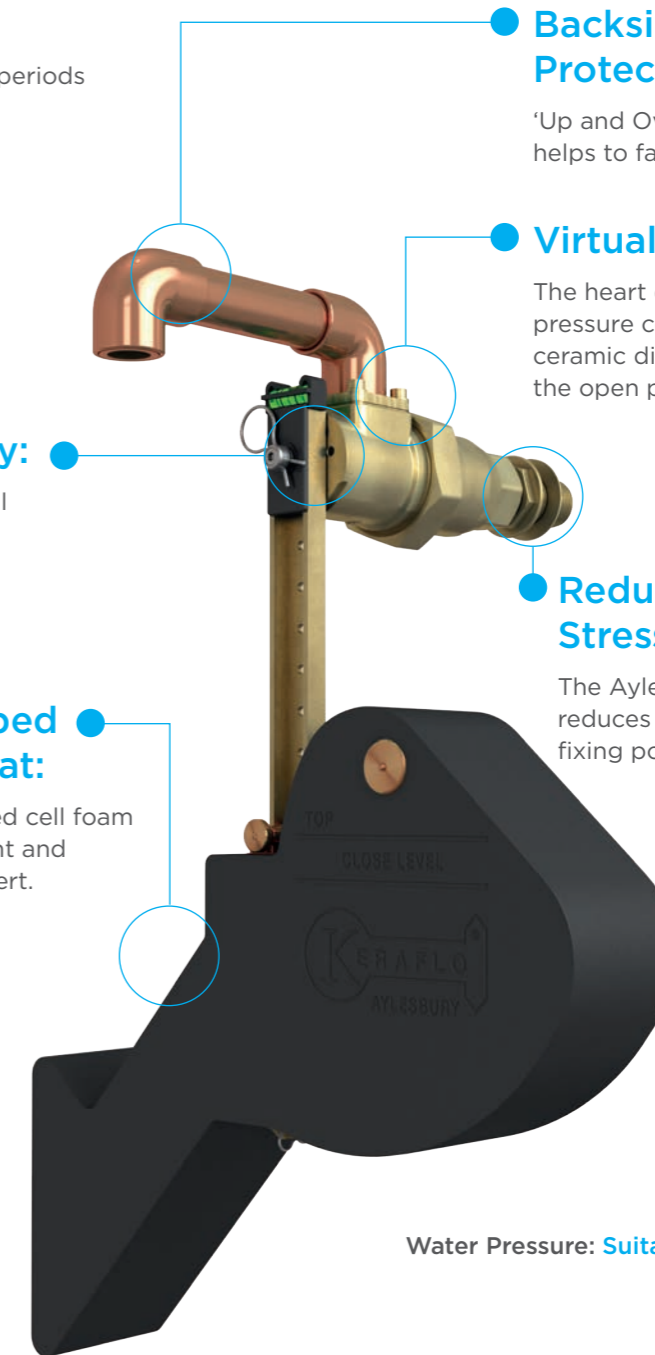

Water Pressure: Suitable for 0 - 10 Bar.

- Ideal for pumped systems
- Improves water turnover
- Reduces Legionellae risk
- Saves energy with positive pump control
- No valve bounce
- Maximises tank capacity
- No dribble
- Fixed and variable level differential models
- No water hammer
- Full flow during fill

The Aylesbury K Type

- Delayed Action Float Valve
- Suitable for tanks without raised valve chambers

How it Works

When water is taken from the tank and the water level falls (when a tap is opened for example), the K Type valve does not immediately open (at a dribble) as would happen with a BS1212 equilibrium valve. There is, instead, a delay; the valve does not open until the water level has fallen by 75mm.

When the water level has fallen by 75mm the K Type valve moves from a 'fully closed' position into a 'fully open' position, allowing water to flow into the tank at a maximum flow rate. When the water level has returned to its original full level, the valve immediately closes from the 'fully open' position, preventing any of the 'dribbling' associated with equilibrium valves.

The positive action and full-bore flow delivered by the K Type valve provides a range of benefits including good water turnover, fast refill, the eradication of water hammer and reduced noise.

- The Aylesbury valve's weighted float can be adjusted to a number of positions on the brass float arm, allowing the tank's stored water level to be easily modified.
- Also available in stainless steel for use in demanding environments such as desalination plants and sea water.

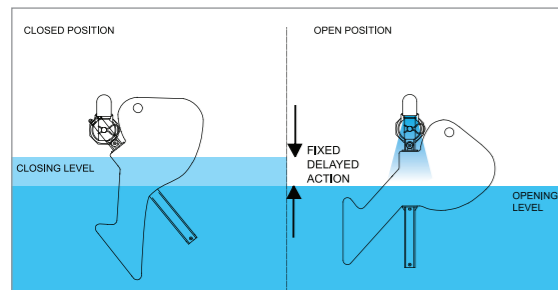
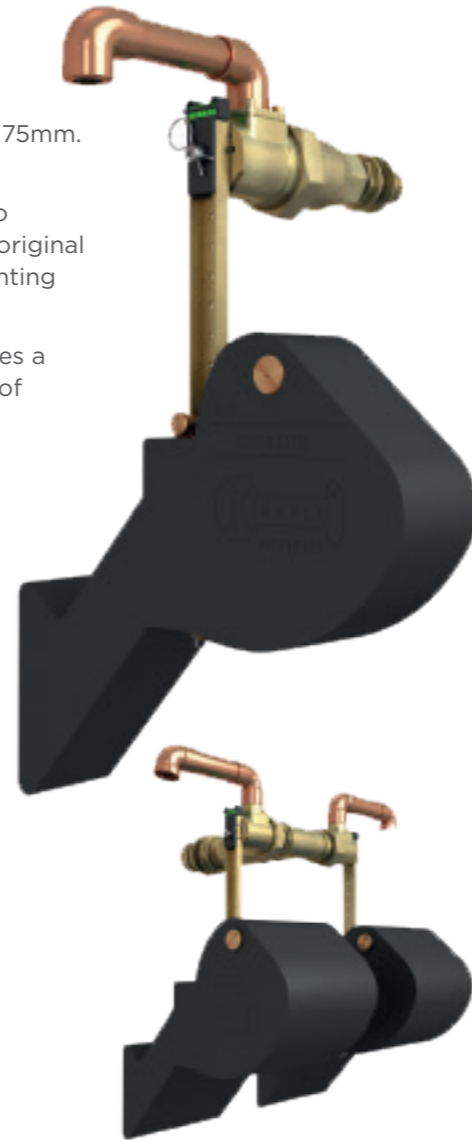

Watch the video on our website
www.keraflo.co.uk/aylesbury-k-type

Sizes for K Type Delayed Action Float Valve

	3/4" (20mm)	1" (25mm)	1 1/4" (32mm)	1 1/2" (40mm)	2" (50mm)
Standard Flow (SF)	✓	✓	✓		✓
High Flow (HF)				✓	✓

	2 1/2" (65mm)	3" (80mm)
Standard Flow (SF)	✓	
High Flow (HF)		
Reduced Bore (RB)		✓



Aylesbury KAX Type

- Delayed Action Float Valve
- Primarily for tanks with raised valve chambers

Identical in operation to the K Type, the Aylesbury KAX Type valves have extended drops and are suitable for raised valve chambers.

The KAX Type valves are primarily designed to fit into chambers or boxes in the covers of tanks calling for air gaps or where maximum tank capacity is required.

To assist with compliance with air gap requirements, the valve discharge is further raised above the centre line of the inlet. The KAX is especially suitable for Type AA and AB air gaps.

- Also available in stainless steel for use in demanding environments such as desalination plants and sea water.

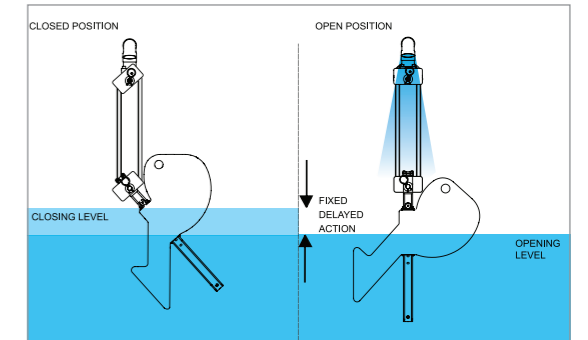

Sizes for KAX Type Delayed Action Float Valve

	3/4" (20mm)	1" (25mm)	1 1/4" (32mm)	1 1/2" (40mm)	2" (50mm)
Standard Flow (SF)	✓	✓	✓		✓
High Flow (HF)				✓	✓

	2 1/2" (65mm)	3" (80mm)
Standard Flow (SF)	✓	
High Flow (HF)		
Reduced Bore (RB)		✓



The Aylesbury KB Type

- Fully Variable Delayed Action Float Valve
- Suitable for tanks with or without raised valve chambers

How it Works

When water is taken from the tank and the water level falls (when a tap is opened for example), the KB Type valve does not immediately open (at a dribble) as would happen with a BS1212 equilibrium valve. There is, instead, a delay; the valve does not open until the water level has fallen to the user-selected level.

When this opening water level is reached the KB Type valve moves from a 'fully closed' position into a 'fully open' position, allowing water to flow into the tank at a maximum flow rate. When the water level has returned to its original full level, the valve immediately closes from the 'fully open' position, preventing any of the 'dribbling' associated with equilibrium valves.

The positive action and full-bore flow delivered by the KB Type valve provide a range of benefits including good water turnover, fast refill, the eradication of water hammer and reduced noise.

- Virtually unlimited range of opening and closing levels – ideal for larger tanks.
- Easy adjustment of variables; capacity can easily be matched to demand.
- Lightweight = reduced tank wall stress and supporting structure not required.
- Suitable for installation directly into a tank or raised valve chamber.

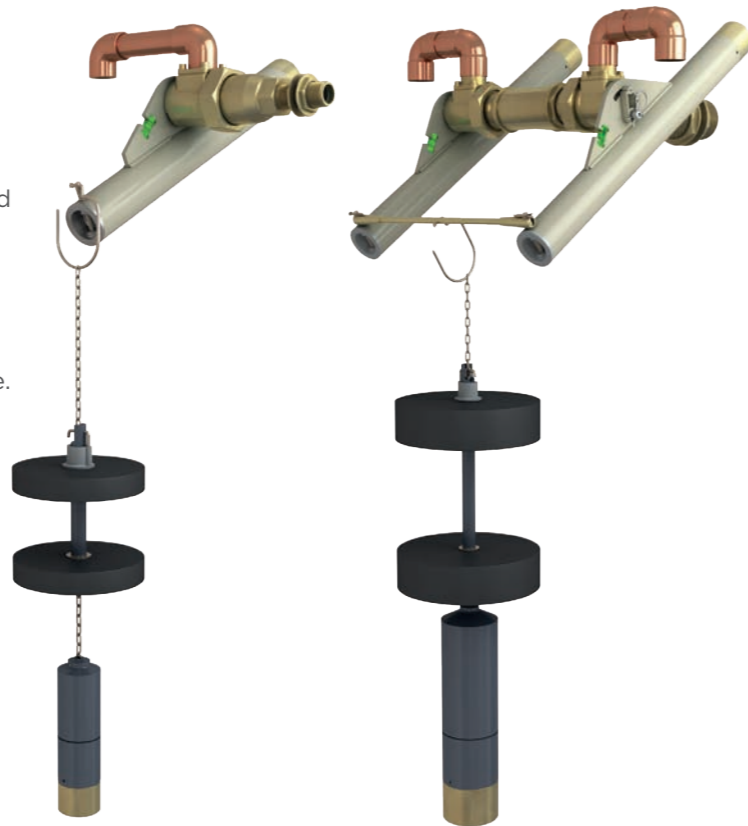

Watch the video on our website
www.keraflo.co.uk/aylesbury-kb-type

Sizes for 'KB' Type Fully Variable Delayed Action Float Valve

	¾" (20mm)	1" (25mm)	1¼"(32mm)	1½"(40mm)	2" (50mm)	2½"(65mm)	3" (80mm)
Standard Flow (SF)	✓	✓	✓	✓	✓	✓	
High Flow (HF)				✓	✓		
Reduced Bore (RB)							✓



The Aylesbury KB Type

Applications

This unique valve is ideal for use with pumped systems, water treatment plants and many other applications including:

- Industrial tanks
- Pumped systems
- Underground tanks
- Rain (grey) water tanks and reservoirs
- Industrial feed and expansion tanks
- Process tanks

For more information on the applications, call our technical support team.

The flexibility of KB valves can assist with improving water quality where buildings are partially commissioned or occupancy varies at different times of the year.

Air Gaps for Industrial Tanks

The KB Type is ideal for fitting into a tank without a lid or raised valve chamber and where the vertical drop from the valve to the water level may be considerable.

Pumped Systems

The adjustable and potentially large difference between opening and closing levels can allow a large volume of water to be admitted to the tank each filling cycle. Pumps and pump sets are often controlled to run for a minimum of 3 minutes. If the water demand is satisfied before this time and an auxiliary hydraulic accumulator is not fitted, the pumps will run against a closed valve head at zero efficiency.

The fill volume can be set to equal or exceed this volume to ensure the pump(s) run for at least 3 minutes. Where a pump set is used solely for transferring water from a break tank to an elevated storage tank, the KB valve can dispense with the need for an auxiliary hydraulic accumulator.

Pump efficiency and initial sizing can be further enhanced using a float valve with little internal resistance. Consequently the High Flow version is often better suited to these applications than the Standard Flow version which is ideal for mains water pressure applications.

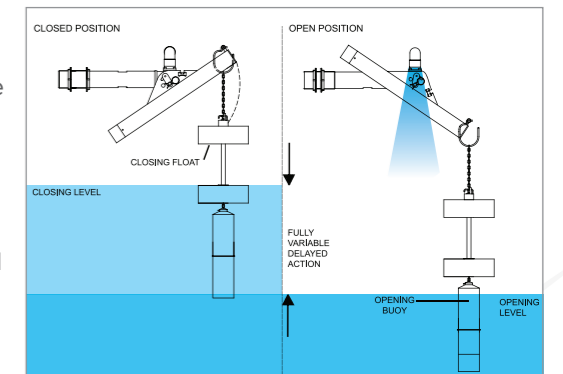

Aylesbury KP Type Float Valve Kit

- Fully Variable Delayed Action Float Valve
- Suitable for tanks with or without raised valve chambers

The KP Type Float Valve Kit comprises an in-line Control Valve together with an Aylesbury KB Type valve acting as a pilot. The pilot valve offers fully variable delayed action opening and closing water level settings, making this ideal for mains or pumped systems.



PILOT VALVE

High Kv Value

The standard KP Control Valve offers excellent flow rate performance.

Raised Valve Chamber

Can be small because it only has to accommodate a 3/4" KB valve and discharge assembly.

Facilitates Air Gaps

The Aylesbury KB valve is supplied with an adjustable chain as standard allowing the closing level to be set below any combination of weir slot, overflow and/or warning device.



CONTROL VALVE

Quiet Operation

Aylesbury valves are quieter than conventional valves due to the elimination of water hammer, valve bounce, 'hiss' and dribble.

Accessibility

An externally mounted Control Valve can be easily inspected, adjusted and, if required, serviced. Re-chlorination of the tank is not necessary provided the tank lid is not removed.

Optional Extra

- Upstream Pressure Sustaining Regulator - the Control Valve regulates itself to leave the desired minimum upstream pressure (Adjustable 1-6 Bar).

Sizes for KP Type Fully Variable Delayed Action Float Valve Kit

1 1/2" (40mm)	2" (50mm)	2 1/2" (65mm)	3" (80mm)	4" (100mm)	6" (150mm)	8" (200mm)
✓	✓	✓	✓	✓	✓	✓

Aylesbury KP Type Float Valve

Benefits

- No water hammer
- Full flow during fill
- Maximises tank capacity
- Maintenance free
- No backing plate required
- Suitable for all types of Air Gap applications
- No valve bounce
- No dribble
- Delayed action
- Tank wall stress negligible
- Ideal for fire sprinkler systems

Flexibility and Ease of Installation

Conventional float valves above 3" are heavy and cumbersome, often necessitating a two person installation.

When the KP Control Valve is mounted outside the tank at floor level, no heavy lifting is required.

The Control Valve can be mounted in one of four positions:

- Vertically in the pipe work (preferred option)
- Outside the tank at floor level
- Outside the tank above the tank water level
- Inside the tank above the tank water level

Multiple Discharges

To reduce the risk of stagnation, two or more discharges can be connected to the outlet of the Control Valve. Since the filling pipe is only subjected to low pressure, thin wall PVC pipe can be used. The KP Valve can also be configured to service balanced / partitioned tanks.

Shallow Tanks

KP Valves can operate in tanks as shallow as 1 metre in depth.

Deep Tanks

The standard Aylesbury KB pilot valve enables an opening level 2m below the inlet level.

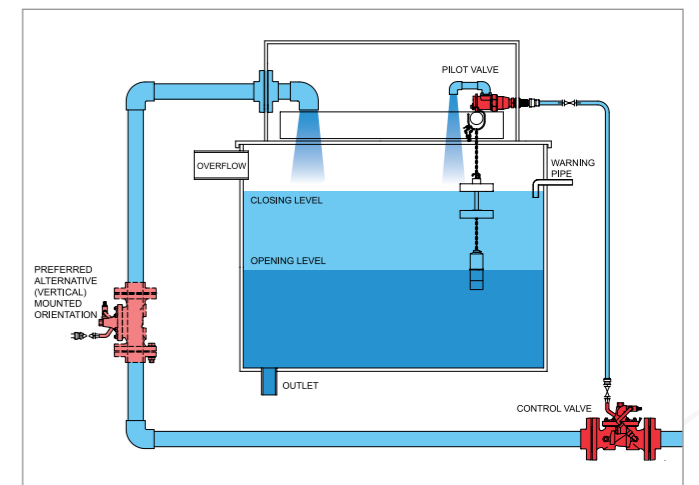

KP Typical Standard Tank Installation

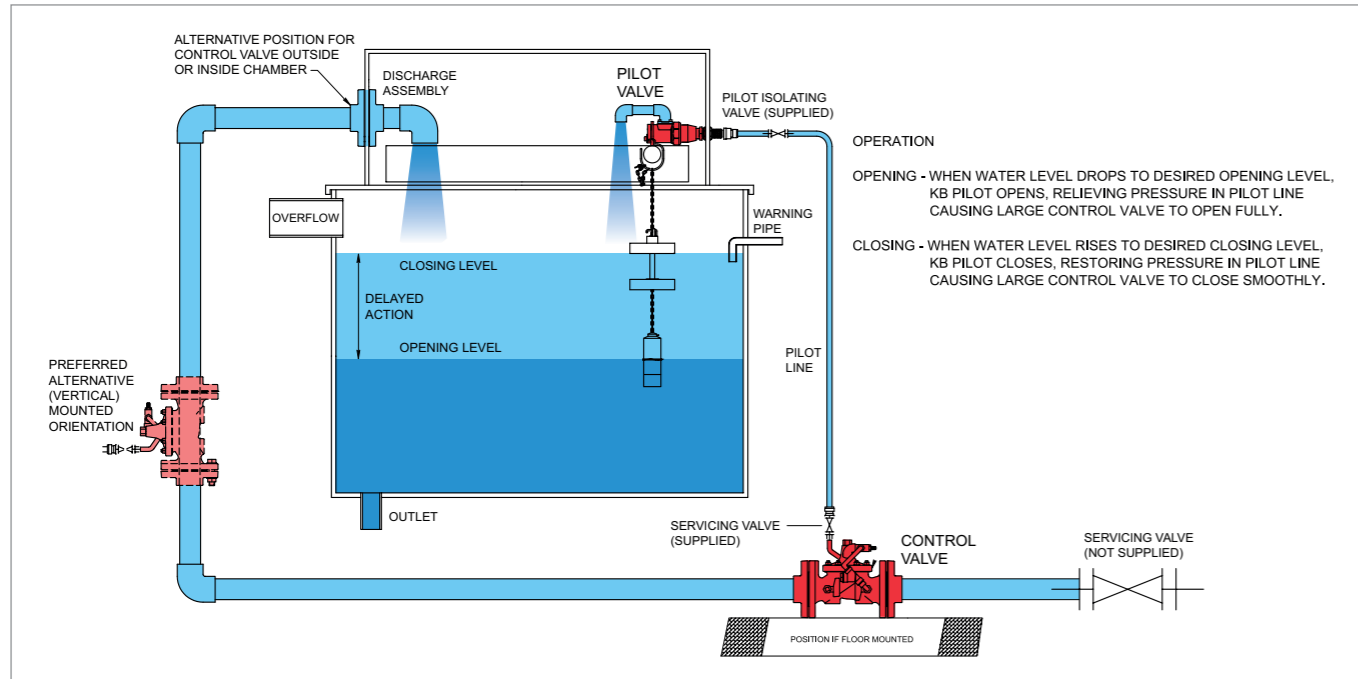

KP Typical Balanced Tanks Installation

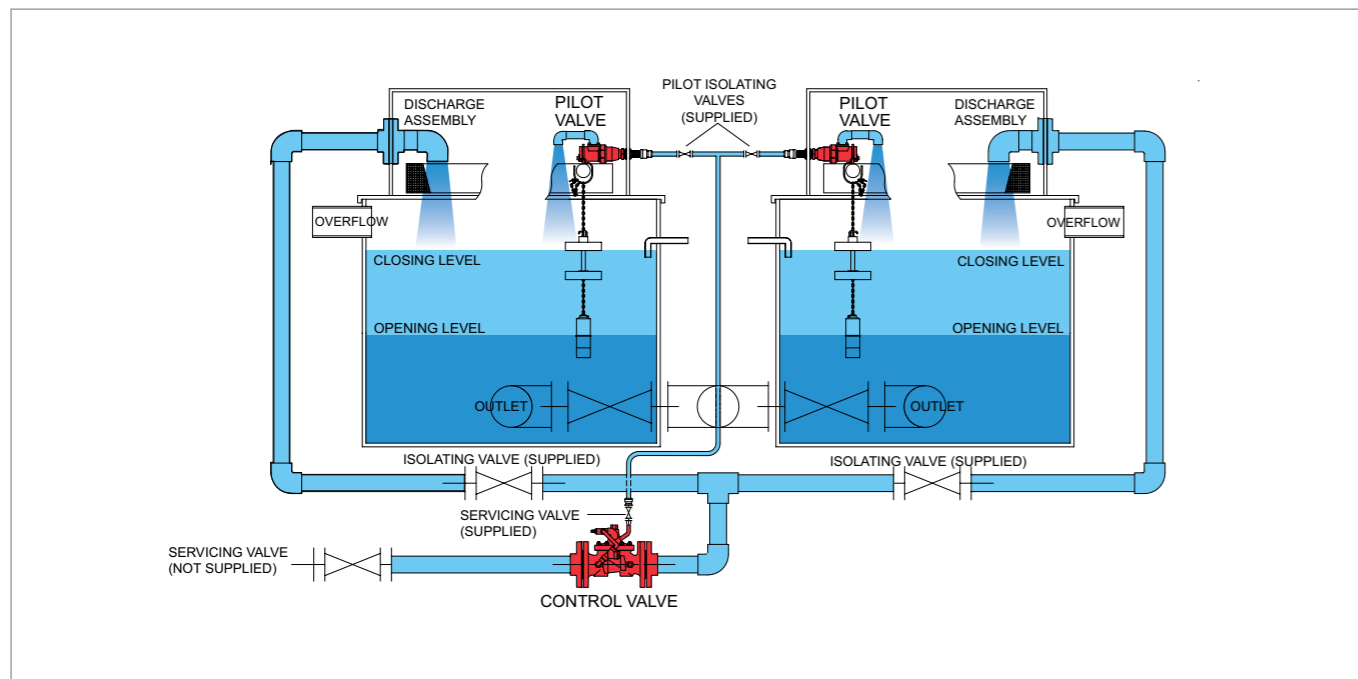

Specification Support

Keraflo's National Sales Team provide the very highest levels of technical advice and specification support at local level, including guidance regarding Water Regulations compliance.

Water Regulations

Keraflo's **UK Water Supply - A Guide to Regulations** publication highlights the design implications of this legislation with regard to float valves. This highly informative document explains air gap types, fluid categories of risk and explains in detail the system design implications of the most common air gap types.

A copy of this guide is available on request or may be downloaded at www.keraflo.co.uk.

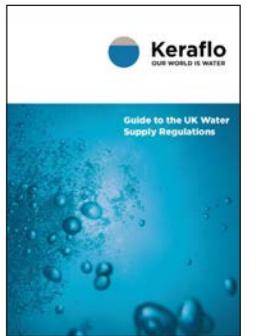

Product Codes

AYLESBURY	CODE	SIZE	DETAIL
Aylesbury K Type	A/K20	3/4" (20mm)	
Aylesbury K Type	A/K25	1" (25mm)	
Aylesbury K Type	A/K32	1 1/4" (32mm)	
Aylesbury K Type	A/K40HF	1 1/2" (40mm)	High Flow Float Valve
Aylesbury K Type	A/K50SF	2" (50mm)	Standard Flow Float Valve
Aylesbury K Type	A/K50HF	2" (50mm)	High Flow Float Valve
Aylesbury K Type	A/K65SF	2 1/2" (65mm)	Standard Flow Float Valve
Aylesbury K Type	A/K80RB	3" (80mm)	Reduced Bore Float Valve
Aylesbury KAX Type	A/KAX20	3/4" (20mm)	
Aylesbury KAX Type	A/KAX25	1" (25mm)	
Aylesbury KAX Type	A/KAX32	1 1/4" (32mm)	
Aylesbury KAX Type	A/KAX40HF	1 1/2" (40mm)	High Flow Float Valve
Aylesbury KAX Type	A/KAX50SF	2" (50mm)	Standard Flow Float Valve
Aylesbury KAX Type	A/KAX50HF	2" (50mm)	High Flow Float Valve
Aylesbury KAX Type	A/KAX65SF	2 1/2" (65mm)	Standard Flow Float Valve
Aylesbury KAX Type	A/KAX80RB	3" (80mm)	Reduced Bore Float Valve
Aylesbury KB Type	A/KB20	3/4" (20mm)	
Aylesbury KB Type	A/KB25	1" (25mm)	
Aylesbury KB Type	A/KB32	1 1/4" (32mm)	
Aylesbury KB Type	A/KB40SF	1 1/2" (40mm)	Standard Flow Float Valve
Aylesbury KB Type	A/KB40HF	1 1/2" (40mm)	High Flow Float Valve
Aylesbury KB Type	A/KB50SF	2" (50mm)	Standard Flow Float Valve
Aylesbury KB Type	A/KB50HF	2" (50mm)	High Flow Float Valve
Aylesbury KB Type	A/KB65SF	2 1/2" (65mm)	Standard Flow Float Valve
Aylesbury KB Type	A/KB80RB	3" (80mm)	Reduced Bore Float Valve
Aylesbury KP Type	A/KP40	1 1/2" (40mm)	Float Valve Kit
Aylesbury KP Type	A/KP50	2" (50mm)	Float Valve Kit
Aylesbury KP Type	A/KP65	2 1/2" (65mm)	Float Valve Kit
Aylesbury KP Type	A/KP80	3" (80mm)	Float Valve Kit
Aylesbury KP Type	A/KP100	4" (100mm)	Float Valve Kit
Aylesbury KP Type	A/KP150	6" (150mm)	Float Valve Kit
Aylesbury KP Type	A/KP200	8" (200mm)	Float Valve Kit
Aylesbury KS Type	A/KS20	3/4" (20mm)	Stainless Steel
Aylesbury KS Type	A/KS25	1" (25mm)	Stainless Steel
Aylesbury KS Type	A/KS32	1 1/4" (32mm)	Stainless Steel
Aylesbury KS Type	A/KS40	1 1/2" (40mm)	Stainless Steel
Aylesbury KS Type	A/KS50	2" (50mm)	Stainless Steel

ALSO
AVAILABLE

TANKTRONIC ELECTRONIC TANK MANAGEMENT SYSTEM

The leading solution to monitoring and controlling water storage tanks.

- Monitors and controls water level and temperature
- Supports single and multiple tanks
- Input and output device connectivity
- Quick-start feature with intuitive interface
- Alarms, fail-safe and holiday schedule functionality
- Alarms can be sent to Building Management Systems (BMS)
- Filling valve options include the Tanktronic Servo Ceramic Valve (SCV)



Control Unit

The unit can manage up to 4 x tank sensors, 8 x Tanktronic Servo Ceramic Valves and 2 x Control Valves plus additional devices.



S-Module

An expansion module that boosts Tanktronic's control capacity. Additional Control Valves and third party devices can be connected to the system.



Sensor

The Sensor monitors both water pressure and temperature. The unit is provided pre-fitted to a connection box for rapid mounting and wiring.



Keraflo Limited, Unit 1, Woodley Park Estate, 56-69 Reading Road, Woodley, Reading, Berkshire, RG5 3AN

0118 921 9920 | info@keraflo.co.uk | www.keraflo.co.uk

A subsidiary of Davidson Holdings Ltd.



Keraflo
OUR WORLD IS WATER