

e-HME

Version with drive and permanent magnet motor (e-SM Drive)

e-HME SERIES e-HM SMART SERIES

Background and context

In every sector, from construction and industry to agriculture and building services the need for intelligent, compact and high-efficiency pumping systems is constantly growing. That's why Lowara has developed the e-HME series: an integrated intelligent pumping system with electronically driven, permanent magnet motor (IE5 efficiency level). The integrated control system, combined with the high performance, power and efficiency from the motor and hydraulics, guarantees impressively low operating costs. You also benefit from flexibility, precision and its ultra-compact size.

Savings

The electronics and permanent magnet motor are highly efficient and minimize power losses while transferring maximum energy to the hydraulic parts of the pump. The refined control system with integrated microprocessor adjusts the motor speed, matching the required operating point of the pump or system requirements. This reduces demand on electricity according to the required working conditions. This creates economies, especially in systems where pump demand varies over time.

Flexibility

The compact size, low loss and increased control make the e-HM Smart series a good choice in applications and systems where fixed speed pumps are commonly used. The e-HM Smart series is easy to integrate in control and regulation loops thanks to the wide availability of compatible communication protocols, including analog and digital inputs. The pump is supplied with a pressure sensor.

Ease of use and commissioning

e-HM Smart has an intuitive interface that guides the user through the installation, and a practical area to assist with connections. The control system is integrated and no additional external electrical panel is required.

Application sectors

- Water supply systems in residential buildings
- Air conditioning
- Water treatment plants
- Industrial installations



e-SM System

- 230V +/- 10% single phase power supply, 50/60 Hz
- Power up to 1,5 kW
- Protection class IP55
- Can be linked up to 3 e-HM Smart pumps

Pump

- Flow rate: up to 29 m³/h
- Head: up to 152 m
- Environment temperature: -20°C to +50°C with no performance derating
- Temperature of pumped liquid: up to +120°C for single-phase motor versions
- Maximum operating pressure 16 bar (PN 16)
- The hydraulic performances meet the tolerances specified in ISO 9906:2012

Motor

- IE5 efficiency level (IEC TS 60034-30-3:2016)
- Synchronous electric motor with permanent magnets, (TEFC), closed structure, air-cooled
- Insulation class 155 (F)
- Overload protection and locked rotor with automatic reset incorporated

e-HME SERIES e-HM SMART SERIES

e-HM Smart series is equipped with an intelligent control that optimizes hydraulic performance while minimizing waste.

Integrated intelligence: The electronic control of the motor enables a 20% increase in performance compared to an equivalent fixed speed pump (area highlighted in figure “Integrated intelligence”).

Adjustment: This is possible both at constant pressure and according to the characteristic curve of the system, based on the customer’s preferences. Another option is according to an external signal or at a preset speed.

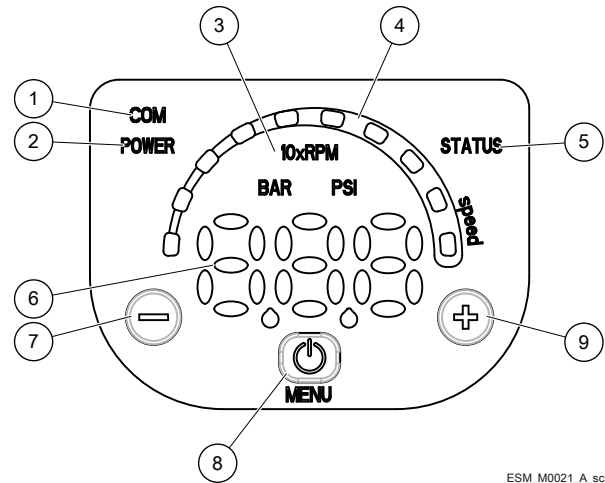
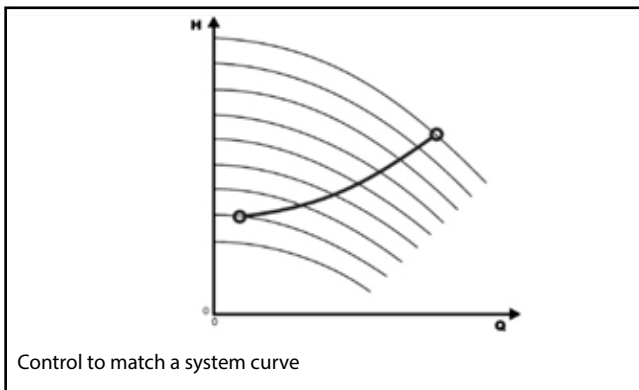
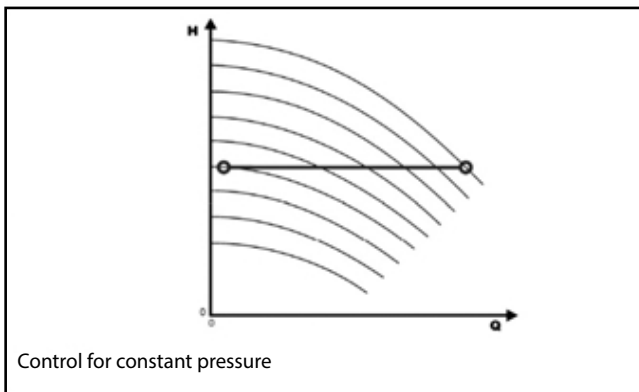
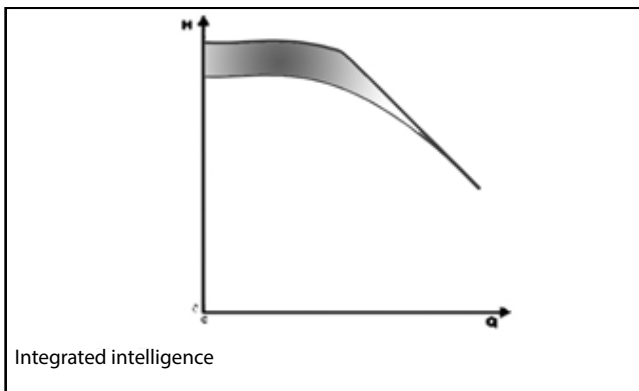

ESM_M0021_A_sc

Intuitive and simple interface: You can control the unit from just three buttons, with an easy to read display for parameters and alarms, designed for complete control of system operation.

- ① Communication LED
- ② Power on LED
- ③ Unit of measure LED
- ④ Speed LED bar
- ⑤ Status LED
- ⑥ Numeric display
- ⑦ \ominus Decrease key
- ⑧ ⏻ On/off and menu key
- ⑨ \oplus Increase key

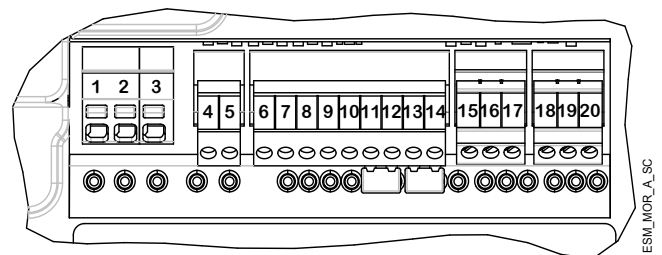

ESM_M0R_A_SC

Terminal block

e-HM Smart has the following terminals:

- 1, 2, 3 = Power supply (\oplus , L, N)
- 4, 5 = Fault signal (NO) - (Ext $V_{max} < 250 \text{ VAC}$ - $I_{max} < 2\text{A}$)
- 6 = Auxiliary voltage supply + 15 VDC
- 7, 8 = Analog 0-10V
- 9 = Power supply external sensor + 15 VDC
- 10 = External sensor 4-20 mA input
- 11, 12 = External start/stop
- 13, 14 = External lack of water
- 15, 16, 17 = Communication bus RS485, protocol Modbus and BACnet
- 18, 19, 20 = Communication bus RS485, enabled via dedicated module

e-HME SERIES
HOW TO READ SMART PUMP SERIES CURVES

To exploit to the maximum potential of Smart Pumps it's important to properly read working curves:

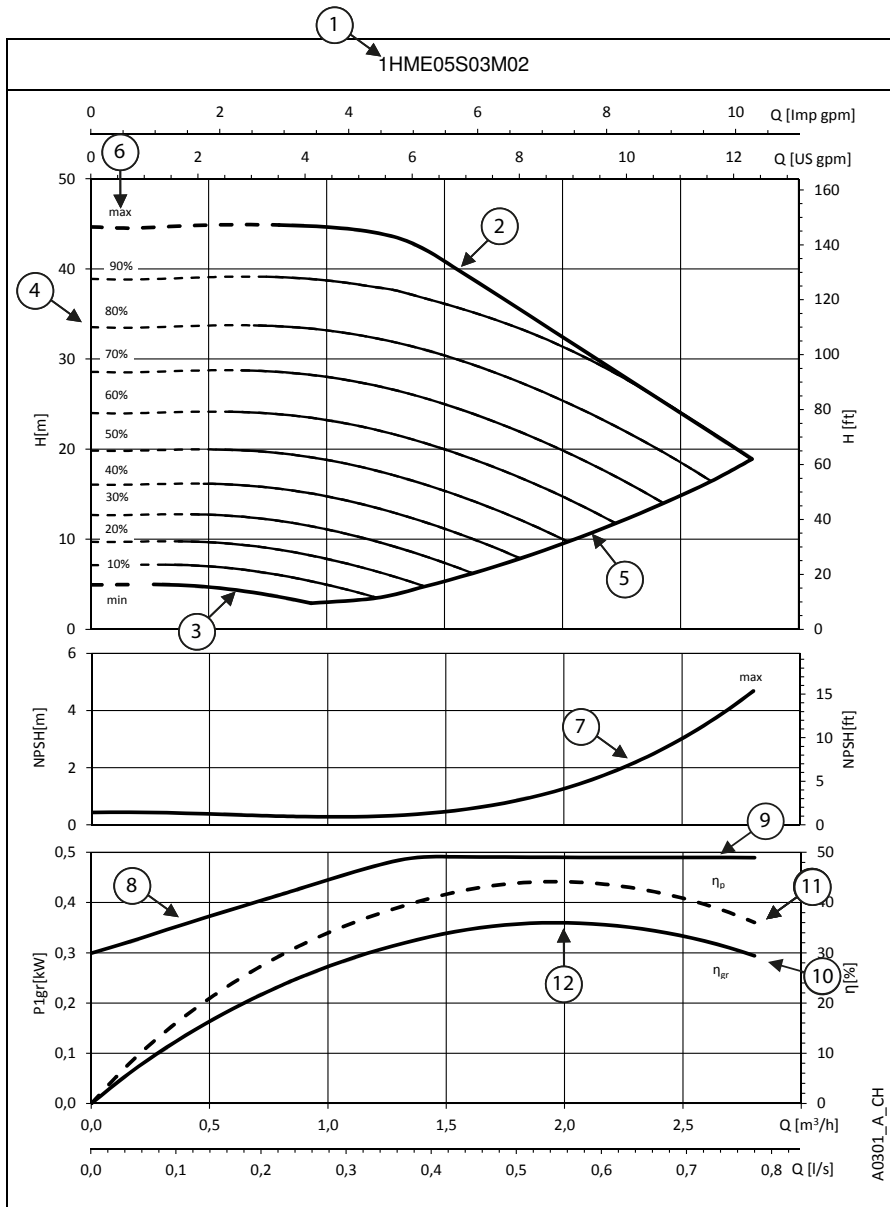

① **Pump model**

② **Maximum speed curve:** equal to 3600 rpm

③ **Minimum speed curve:** it refers to the minimum rpm level the motor can work at, it's calculated depending on the model of pump maximizing for each one the working area and allowing the highest system flexibility.

④ The **area with dotted lines** is where the pump can only operate intermittently for short periods of time.

⑤ Each **intermediate curve** between max and min speed shows the percentage of load the pump+motor+drive system is working at; it's easy to read also from the LED speed bar on the HMI keypad: at 90% there will be 9 led, at 80% there will be 8 and so on.

Example: at 60% there will be 6 lit led's

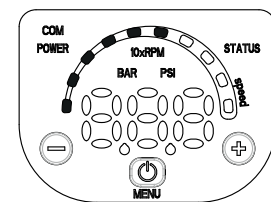

⑥ The **part load percentage** is calculated depending on maximum speed (*max*, 100%) and minimum speed (*min*, equal to 0%, which is the minimum part load step, below it the drive stays powered up but cannot work).

⑦ **NPSH**: is the net positive suction head of pump+motor+drive system working at maximum speed.

⑧ **P1_{gr}** is the power absorption in kW of pump+motor+drive system working at maximum speed.

⑨ **Load control**: the Smart Pump controls and limits power consumption at high flow/low head, in this way the motor stays protected from overload and ensure a longer life of pump+motor+drive system.

⑩ **η_{gr}** is the efficiency of pump+motor+drive system working at maximum speed.

⑪ **η_p** is the efficiency of the hydraulic part, working at maximum speed.

⑫ **Working point**: it's important to make sure the pump is working at the best working point, the one at highest efficiency.

It's easy to find it: it's the highest point of the η_p pump efficiency curve; once you found it, you can learn also flow values from x-axis called Q and head values from y-axis called H which allow the system to work at the best working point.

1, 3, 5, 10, 15HME..S SERIES HYDRAULIC PERFORMANCE TABLE

PUMP TYPE HME..S, HME..N Single-phase	MOTOR		e-SM SET		Q = DELIVERY							
	P _N kW	TYPE 1x230 V	* P ₁ kW	* I 208-240 V A	l/min 0	6,7	13,3	20,0	26,7	33,3	40,0	46,7
					m ³ /h 0	0,4	0,8	1,2	1,6	2,0	2,4	2,8
H = TOTAL HEAD IN METRES OF COLUMN OF WATER												
1HME05S03M02	0,37	ESM80/103 HM..	0,49	2,24	44,7	44,8	44,9	44,1	39,2	32,5	25,7	
1HME08S05M02	0,55	ESM80/105 HM..	0,69	3,07	71,6	71,5	71,7	70,4	60,3	50,0	39,6	
1HME11S07M02	0,75	ESM80/107 HM..	0,91	4,04	98,5	98,5	98,8	94,3	80,7	66,8	52,9	
1HME15S11M02	1,1	ESM80/111 HM..	1,33	5,85	134,0	134,4	134,6	132,3	119,5	99,5	79,6	
1HME17S15M02	1,5	ESM80/115 HM..	1,77	7,77	151,8	152,2	152,7	149,6	141,6	128,6	110,7	

PUMP TYPE HME..S, HME..N Single-phase	MOTOR		e-SM SET		Q = DELIVERY							
	P _N kW	TYPE 1x230 V	* P ₁ kW	* I 208-240 V A	l/min 0	13,3	26,7	40,0	53,3	66,7	80,0	86,7
					m ³ /h 0	0,8	1,6	2,4	3,2	4,0	4,8	5,2
H = TOTAL HEAD IN METRES OF COLUMN OF WATER												
3HME03S03M02	0,37	ESM80/103 HM..	0,49	2,24	33,3	33,9	33,4	31,5	25,6	20,1	14,6	11,8
3HME05S05M02	0,55	ESM80/105 HM..	0,69	3,07	55,5	56,5	55,7	47,5	38,2	29,4	20,5	16,0
3HME07S07M02	0,75	ESM80/107 HM..	0,91	4,06	77,6	79,1	78,1	64,9	52,0	39,8	27,5	21,3
3HME09S11M02	1,1	ESM80/111 HM..	1,33	5,85	99,8	101,8	100,3	93,6	76,1	59,6	43,0	34,7
3HME12S15M02	1,5	ESM80/115 HM..	1,78	7,80	133,1	135,9	133,6	127,3	103,6	81,5	59,2	48,1

PUMP TYPE HME..S, HME..N Single-phase	MOTOR		e-SM SET		Q = DELIVERY							
	P _N kW	TYPE 1x230 V	* P ₁ kW	* I 208-240 V A	l/min 0	23,3	46,7	70,0	93,3	116,7	140,0	170,0
					m ³ /h 0	1,4	2,8	4,2	5,6	7,0	8,4	10,2
H = TOTAL HEAD IN METRES OF COLUMN OF WATER												
5HME02S03M02	0,37	ESM80/103 HM..	0,49	2,24	22,2	22,4	21,9	19,8	16,2	13,0	9,9	6,0
5HME03S05M02	0,55	ESM80/105 HM..	0,69	3,07	33,3	33,6	32,9	29,5	24,1	19,3	14,7	8,8
5HME04S07M02	0,75	ESM80/107 HM..	0,91	4,05	44,4	44,7	43,8	40,1	32,8	26,4	20,2	12,2
5HME06S11M02	1,1	ESM80/111 HM..	1,33	5,85	66,7	67,2	65,8	59,0	48,1	38,7	29,5	17,5
5HME08S15M02	1,5	ESM80/115 HM..	1,78	7,82	88,9	89,5	87,7	80,2	65,5	52,8	40,4	24,4

PUMP TYPE HME..S, HME..N Single-phase	MOTOR		e-SM SET		Q = DELIVERY							
	P _N kW	TYPE 1x230 V	* P ₁ kW	* I 208-240 V A	l/min 0	40,0	80,0	120,0	160,0	200,0	240,0	283,3
					m ³ /h 0	2,4	4,8	7,2	9,6	12,0	14,4	17,0
H = TOTAL HEAD IN METRES OF COLUMN OF WATER												
10HME01S07M02	0,75	ESM80/107 HM..	0,86	3,80	17,5	17,5	17,0	16,1	14,7	12,7	10,2	6,6
10HME02S11M02	1,1	ESM80/111 HM..	1,33	5,85	34,8	34,9	33,8	32,3	27,2	21,9	16,6	11,1
10HME03S15M02	1,5	ESM80/115 HM..	1,78	7,81	52,4	51,8	50,6	46,9	39,2	32,2	25,3	17,8

PUMP TYPE HME..S, HME..N Single-phase	MOTOR		e-SM SET		Q = DELIVERY							
	P _N kW	TYPE 1x230 V	* P ₁ kW	* I 208-240 V A	l/min 0	70,0	140,0	210,0	280,0	350,0	420,0	483,3
					m ³ /h 0	4,2	8,4	12,6	16,8	21,0	25,2	29,0
H = TOTAL HEAD IN METRES OF COLUMN OF WATER												
15HME01S11M02	1,1	ESM80/111 HM..	1,33	5,85	20,9	20,5	19,7	18,8	16,4	12,7	8,8	5,2
15HME02S15M02	1,5	ESM80/115 HM..	1,79	7,85	42,7	41,8	35,9	29,8	24,2	18,2	11,3	5,1

* Maximum value in specified range: P₁ = input power; I = input current.

1-15hmes-esm-2p50-en_a_th

ELECTRICAL DATA TABLE

P _N kW	MOTOR TYPE	IEC SIZE	Construction Design	SPEED (RPM) min ⁻¹	INPUT CURRENT I (A) 208-240 V	DATA RELATED TO THE VOLTAGE OF 230V						
						I _n A	cosφ	T _n Nm	η %			IES
0,37	ESM80/103 HM..	80	SPECIAL	3000	2,28-1,99	2,08	0,95	1,18	81,3	79,1	74,3	2
				3600	2,30-2,02	2,10		0,98	80,6	77,5	72,0	
0,55	ESM80/105 HM..	80		3000	3,27-2,85	2,96	0,97	1,75	83,3	82,2	78,8	2
				3600	3,27-2,85	2,96		1,46	83,3	81,5	77,5	
0,75	ESM80/107 HM..	80		3000	4,43-3,84	4,00	0,98	2,39	83,3	83,3	81,5	2
				3600	4,38-3,79	3,94		1,99	84,5	83,5	80,6	
1,10	ESM80/111 HM..	80		3000	6,26-5,35	5,64	0,99	3,50	85,7	85,1	82,7	2
				3600	6,20-5,32	5,63		2,92	85,9	84,6	81,4	
1,50	ESM80/115 HM..	80		3000	8,57-7,32	7,69	0,99	4,77	85,6	85,7	84,7	2
				3600	8,42-7,25	7,62		3,98	86,3	85,9	84,0	

* The indicated rotational speed are representing the upper and lower limits of the rated power operational speed range.

eHM-eVM_Smart-motm_en_a_th

In the range 3000-3600 rpm the nominal motor power is guaranteed. Above 3600 rpm it isn't possible work and the motor is automatically limited; below 3000 rpm it works partially load.

1, 3, 5HME..S SERIES DIMENSIONS AND WEIGHTS

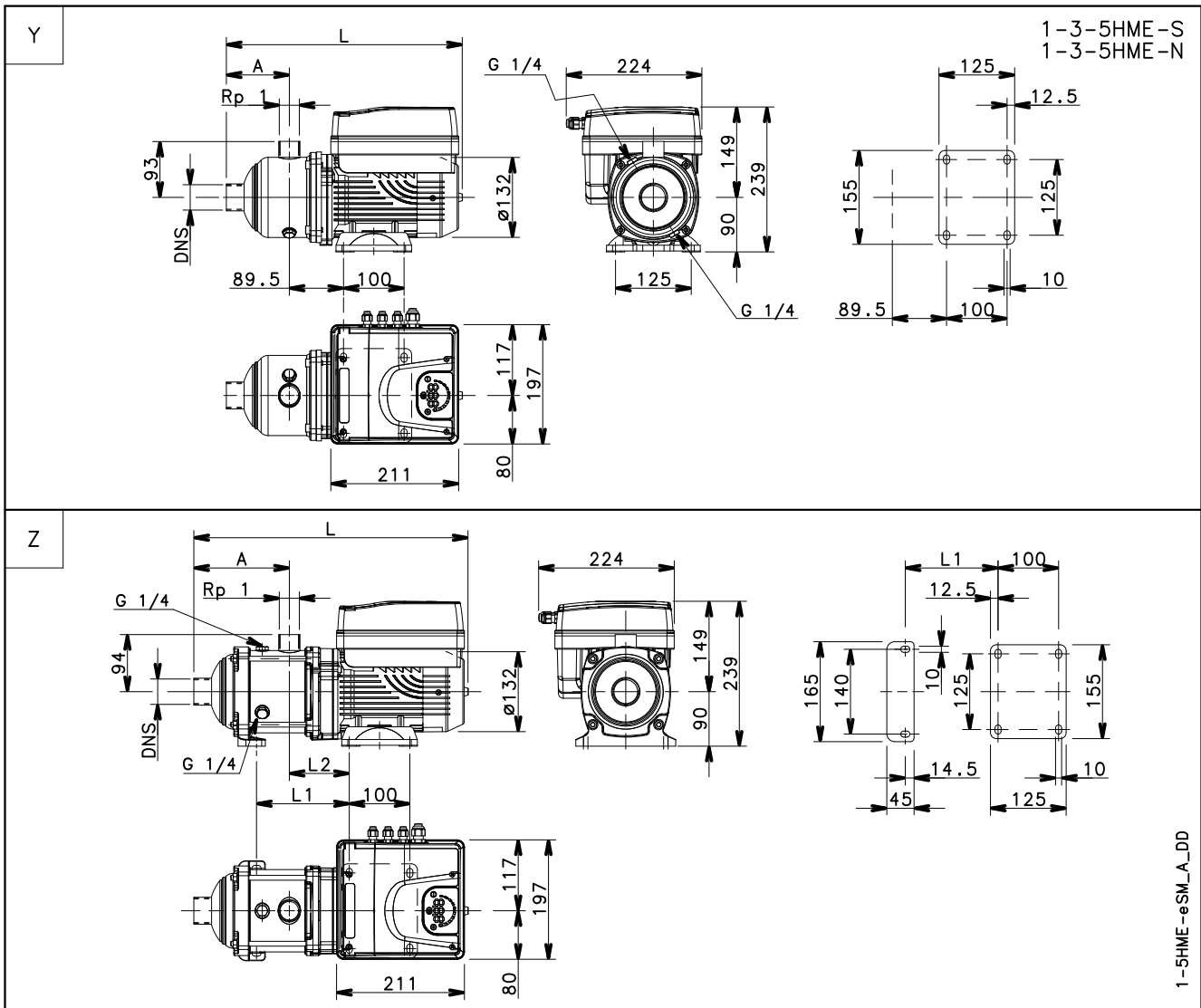

1-5HME-eSM-A_DD

PUMP TYPE	VERSION	Ref.	MOTOR		DIMENSIONS (mm)					PN	WEIGHT
			kW	SIZE	A	DNS	L	L1	L2		
1HME05S03M02	SINGLE-PHASE	Y	0,37	80	127	Rp 1	414	-	-	10	10
1HME08S05M02		Z	0,55	80	171	Rp 1	467	168	99	10	12
1HME11S07M02		Z	0,75	80	231	Rp 1	527	228	99	10	13
1HME15S11M02		Z	1,1	80	311	Rp 1	607	308	99	16	15
1HME17S15M02		Z	1,5	80	351	Rp 1	647	348	99	16	16
3HME03S03M02	SINGLE-PHASE	Y	0,37	80	87	Rp 1	374	-	-	10	9
3HME05S05M02		Z	0,55	80	127	Rp 1	414	-	-	10	10
3HME07S07M02		Z	0,75	80	151	Rp 1	447	148	99	10	11
3HME09S11M02		Z	1,1	80	191	Rp 1	487	188	99	16	14
3HME12S15M02		Z	1,5	80	251	Rp 1	547	248	99	16	15
5HME02S03M02	SINGLE-PHASE	Y	0,37	80	104	Rp 1 1/4	391	-	-	10	9
5HME03S05M02			0,55	80	104	Rp 1 1/4	391	-	-	10	9
5HME04S07M02			0,75	80	129	Rp 1 1/4	416	-	-	10	10
5HME06S11M02		Z	1,1	80	158	Rp 1 1/4	454	153	99	10	12
5HME08S15M02			1,5	80	208	Rp 1 1/4	504	203	99	10	14

1HME..S SERIES OPERATING CHARACTERISTICS

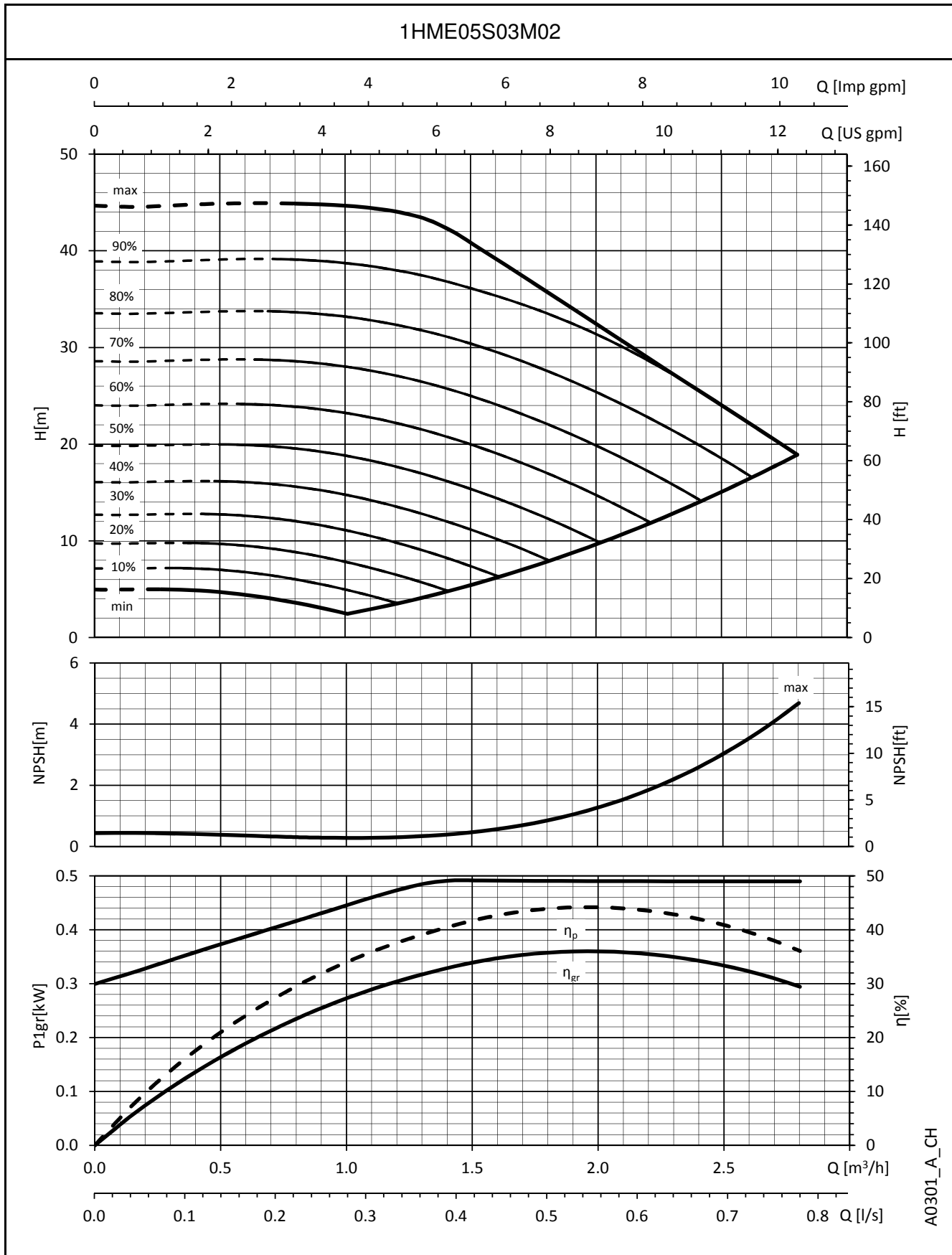

A0301_A_CH

The performances are valid for liquid with density $\rho = 1 \text{ Kg/dm}^3$ and kinematic viscosity $\nu = 1 \text{ mm}^2/\text{sec}$.

1HME..S SERIES OPERATING CHARACTERISTICS

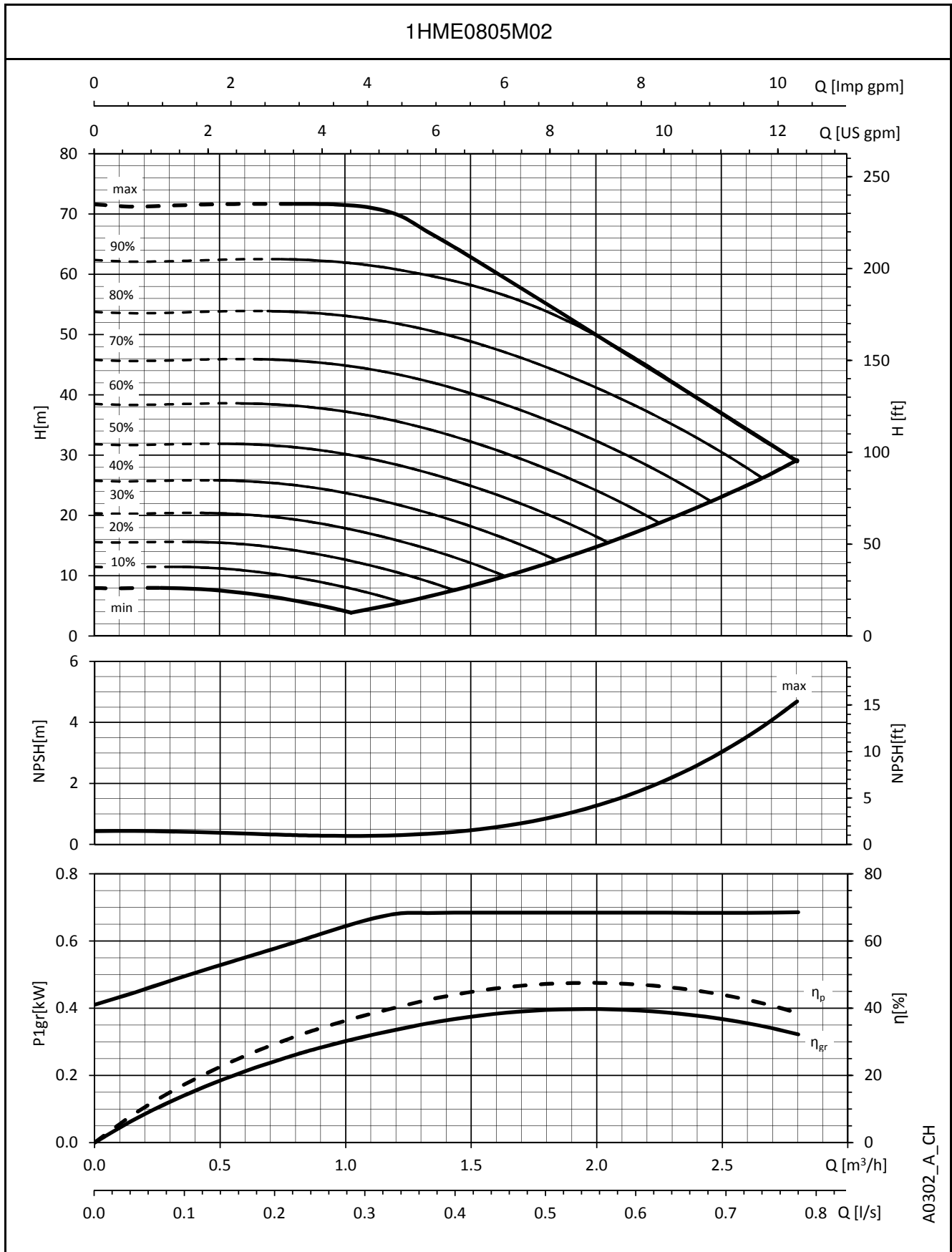

A0302_A_CH

The performances are valid for liquid with density $\rho = 1 \text{ Kg/dm}^3$ and kinematic viscosity $\nu = 1 \text{ mm}^2/\text{sec}$.

1HME..S SERIES OPERATING CHARACTERISTICS

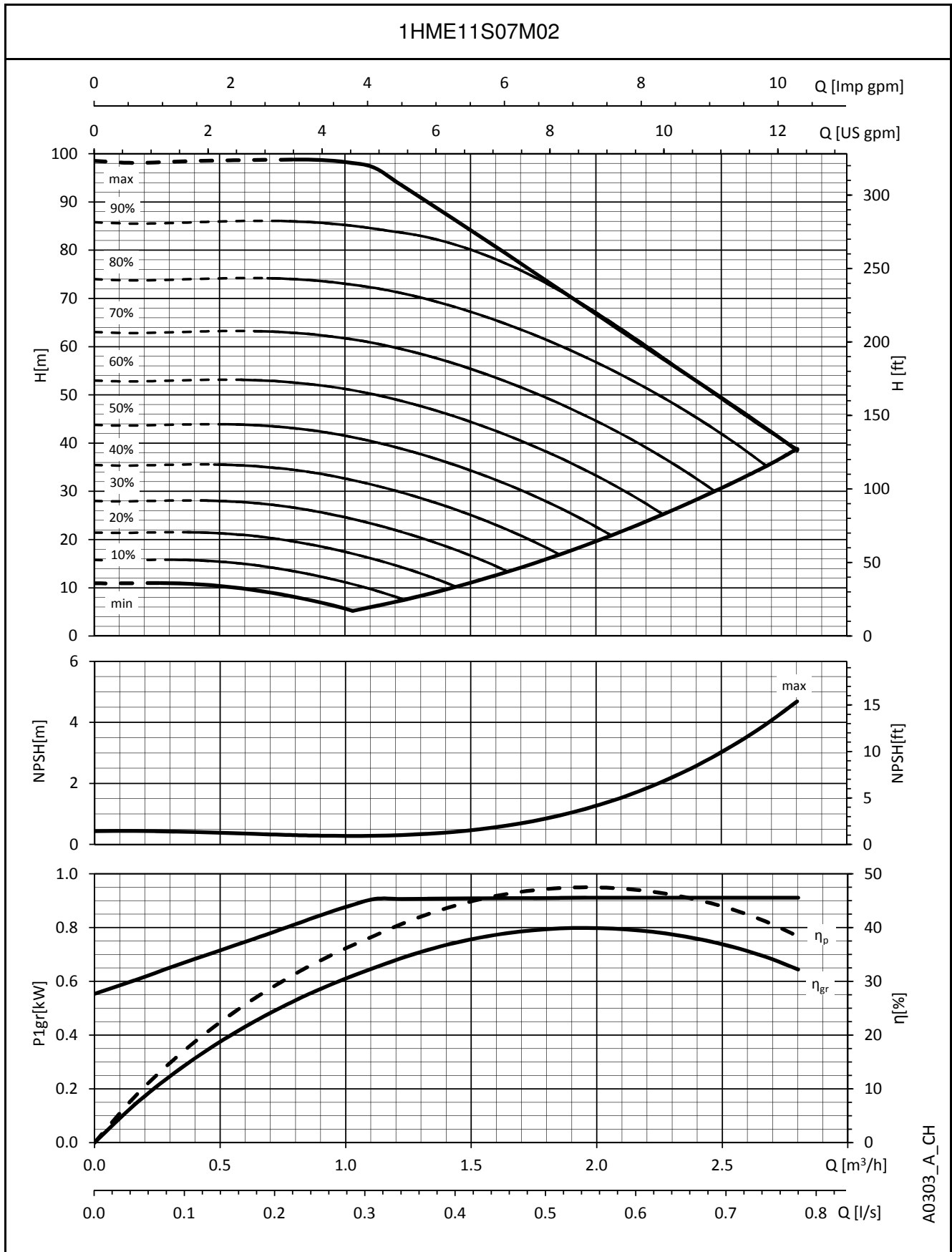

A0303_A_CH

The performances are valid for liquid with density $\rho = 1 \text{ Kg/dm}^3$ and kinematic viscosity $\nu = 1 \text{ mm}^2/\text{sec}$.

1HME..S SERIES OPERATING CHARACTERISTICS

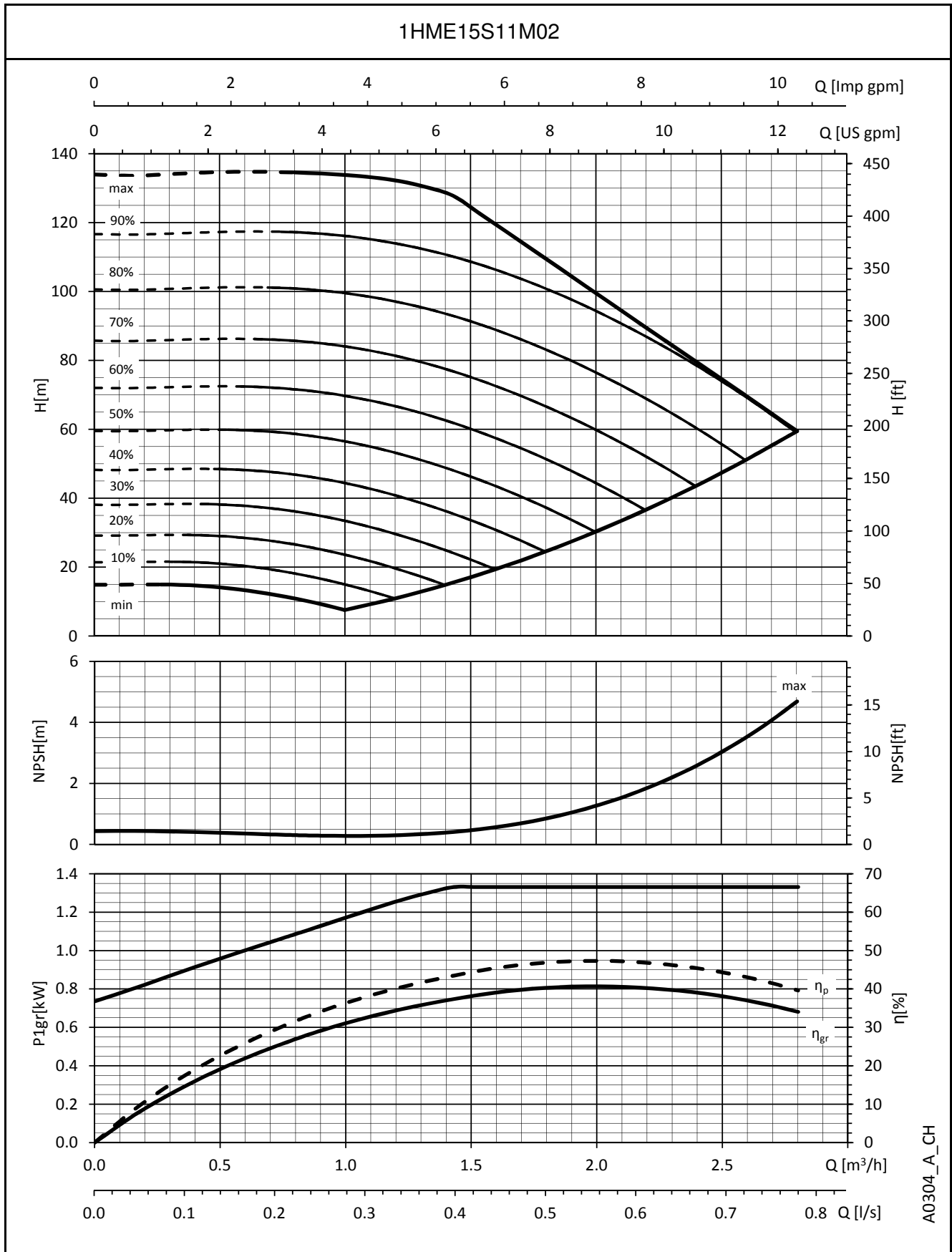

A0304_A_CH

The performances are valid for liquid with density $\rho = 1 \text{ Kg/dm}^3$ and kinematic viscosity $\nu = 1 \text{ mm}^2/\text{sec}$.

1HME..S SERIES OPERATING CHARACTERISTICS

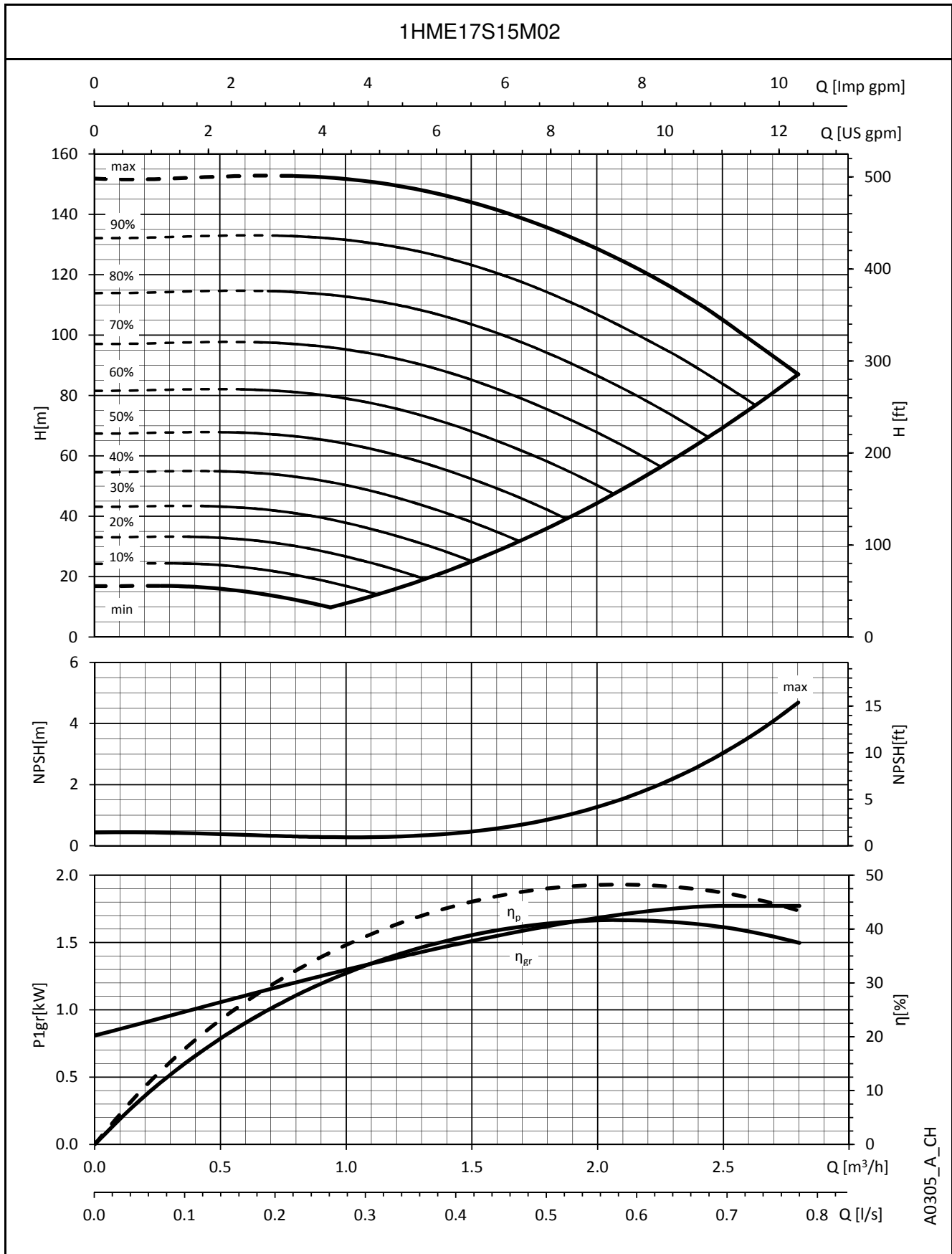

A0305_A_CH

The performances are valid for liquid with density $\rho = 1 \text{ Kg/dm}^3$ and kinematic viscosity $\nu = 1 \text{ mm}^2/\text{sec}$.

3HME..S SERIES OPERATING CHARACTERISTICS

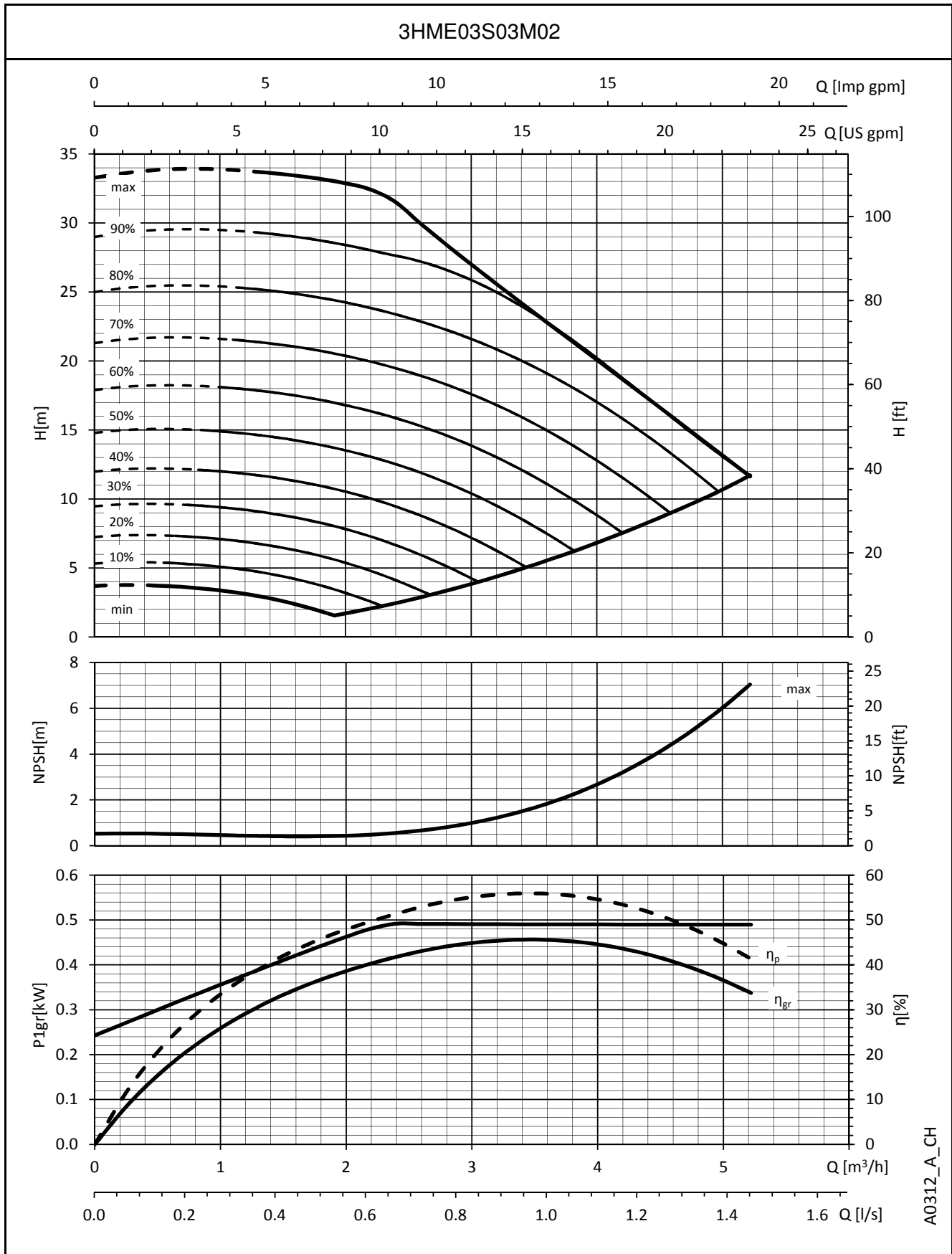

A0312_A_CH

The performances are valid for liquid with density $\rho = 1 \text{ Kg/dm}^3$ and kinematic viscosity $\nu = 1 \text{ mm}^2/\text{sec}$.

3HME..S SERIES OPERATING CHARACTERISTICS

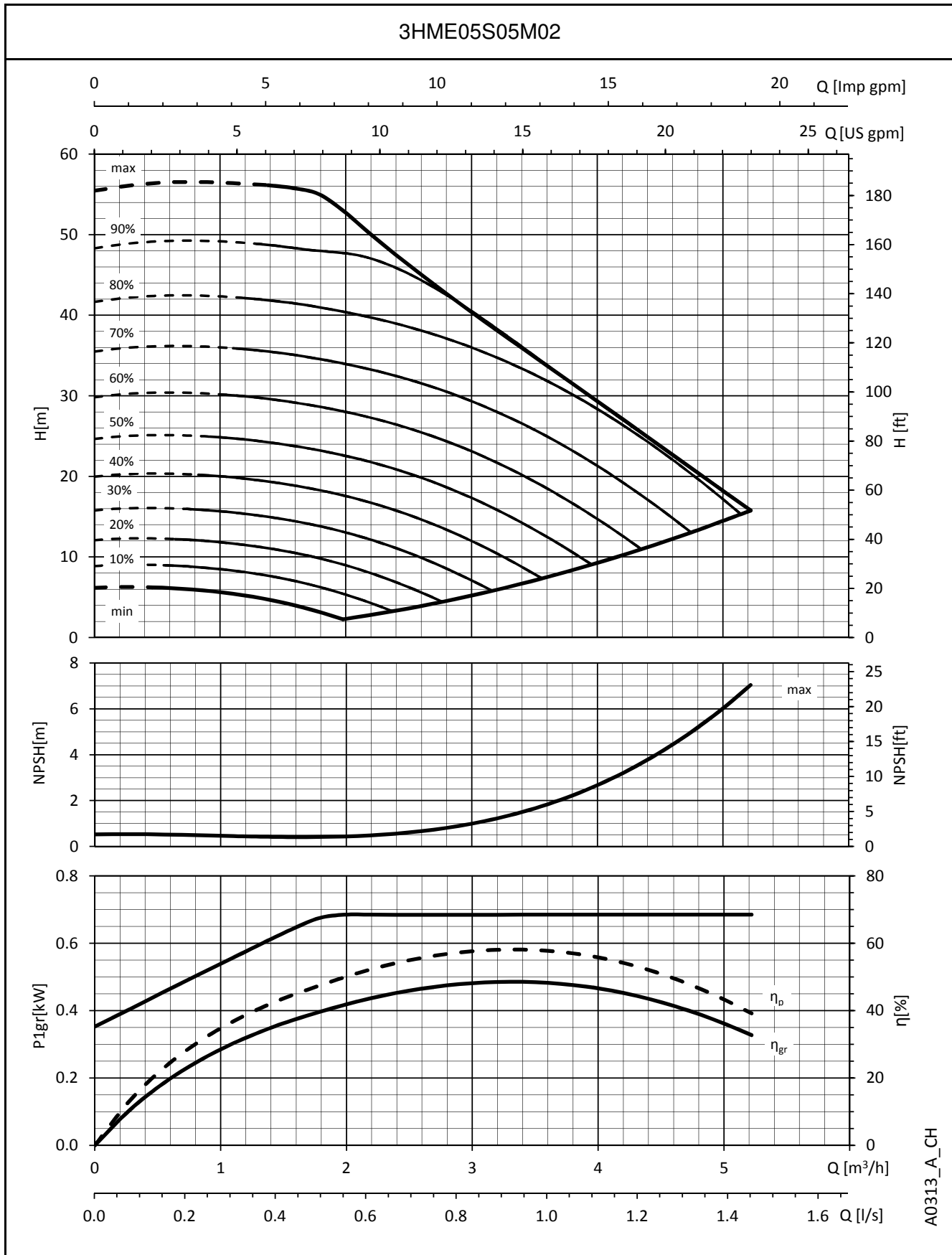

A0313_A_CH

The performances are valid for liquid with density $\rho = 1 \text{ Kg/dm}^3$ and kinematic viscosity $\nu = 1 \text{ mm}^2/\text{sec}$.

3HME..S SERIES OPERATING CHARACTERISTICS

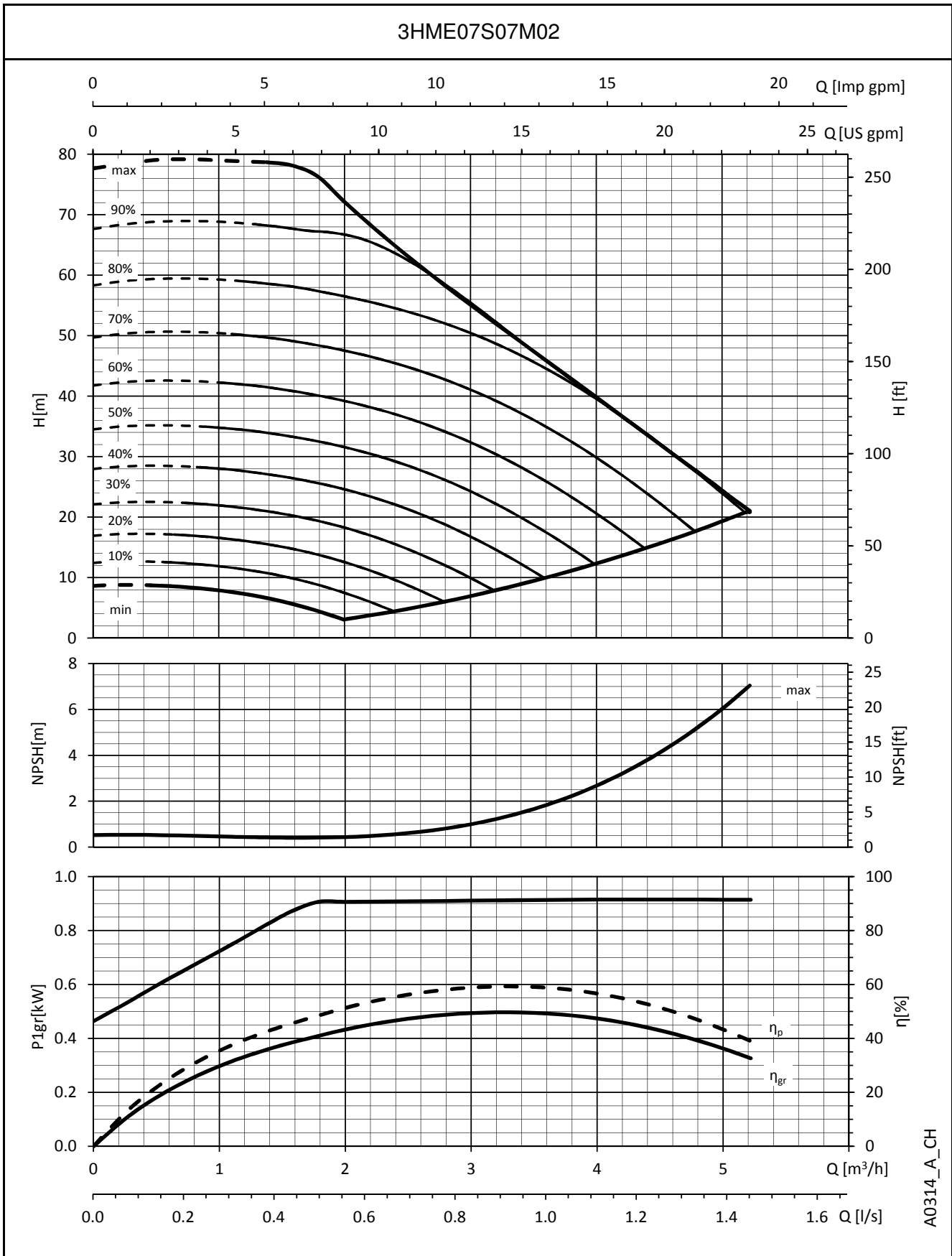

A0314_A_CH

The performances are valid for liquid with density $\rho = 1 \text{ Kg/dm}^3$ and kinematic viscosity $\nu = 1 \text{ mm}^2/\text{sec}$.

3HME..S SERIES OPERATING CHARACTERISTICS

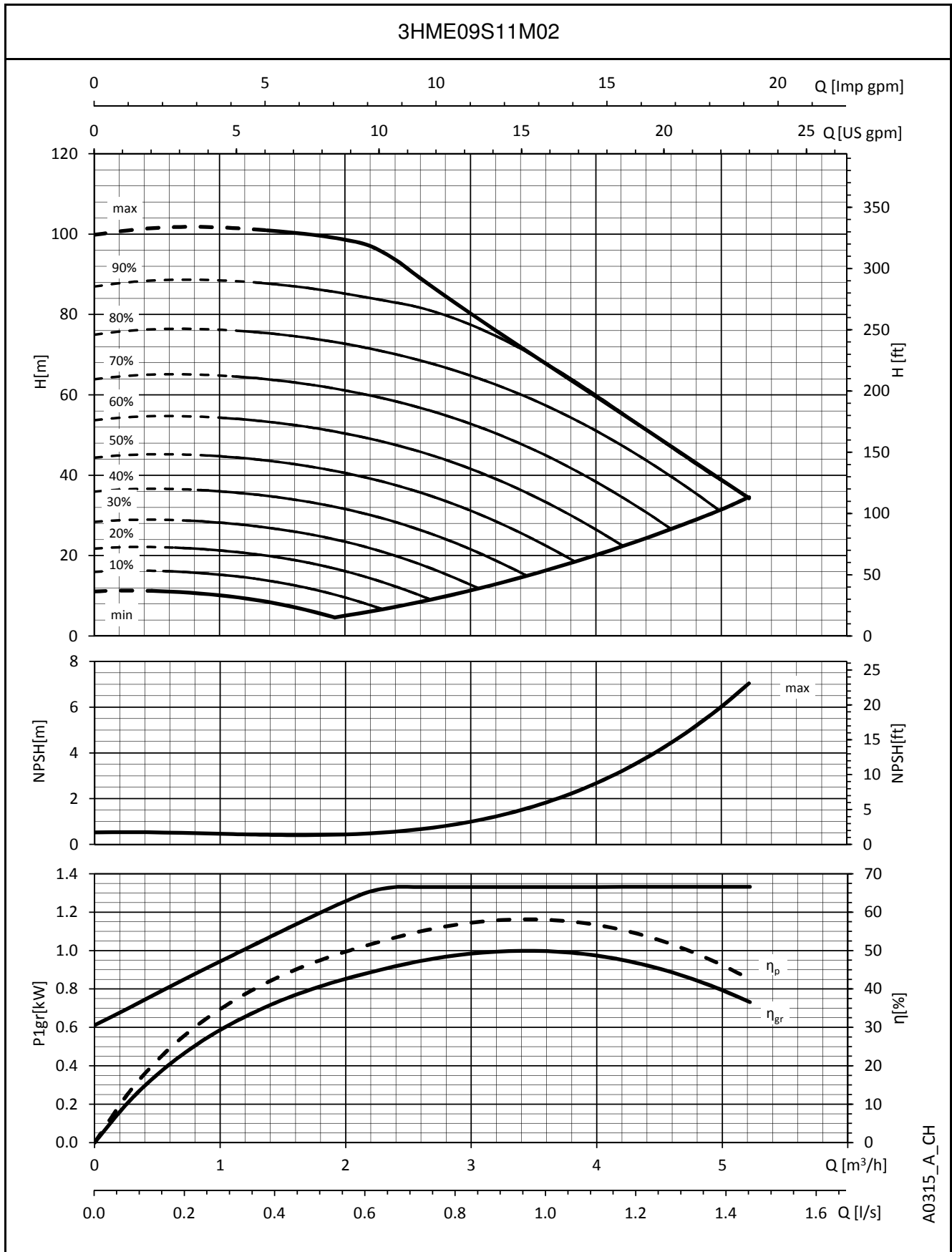

A0315_A_CH

The performances are valid for liquid with density $\rho = 1 \text{ Kg/dm}^3$ and kinematic viscosity $\nu = 1 \text{ mm}^2/\text{sec}$.

3HME..S SERIES OPERATING CHARACTERISTICS

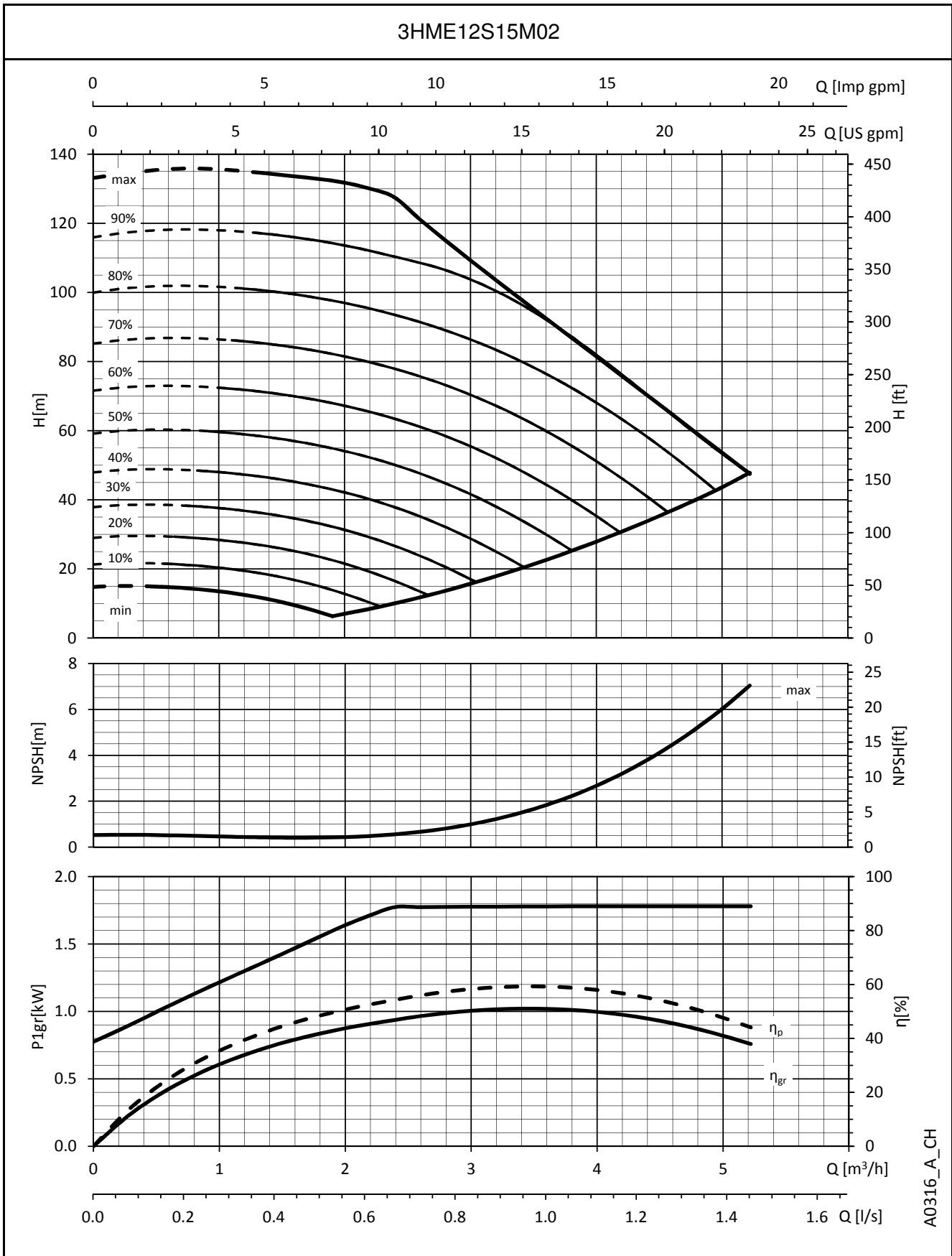

A0316_A_CH

The performances are valid for liquid with density $\rho = 1 \text{ Kg/dm}^3$ and kinematic viscosity $\nu = 1 \text{ mm}^2/\text{sec}$.

5HME..S SERIES OPERATING CHARACTERISTICS

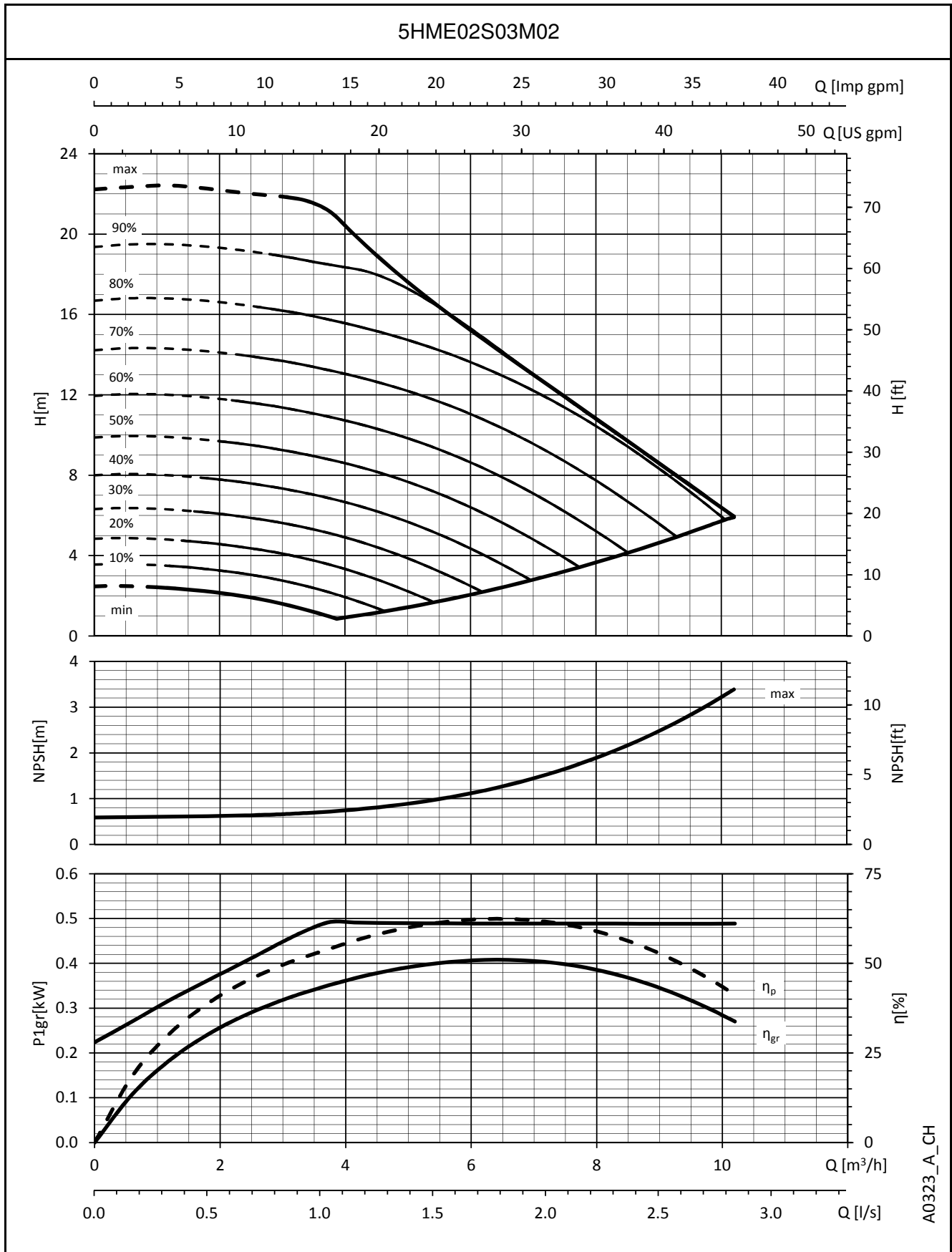

A0323_A_CH

The performances are valid for liquid with density $\rho = 1 \text{ Kg/dm}^3$ and kinematic viscosity $\nu = 1 \text{ mm}^2/\text{sec}$.

5HME..S SERIES OPERATING CHARACTERISTICS

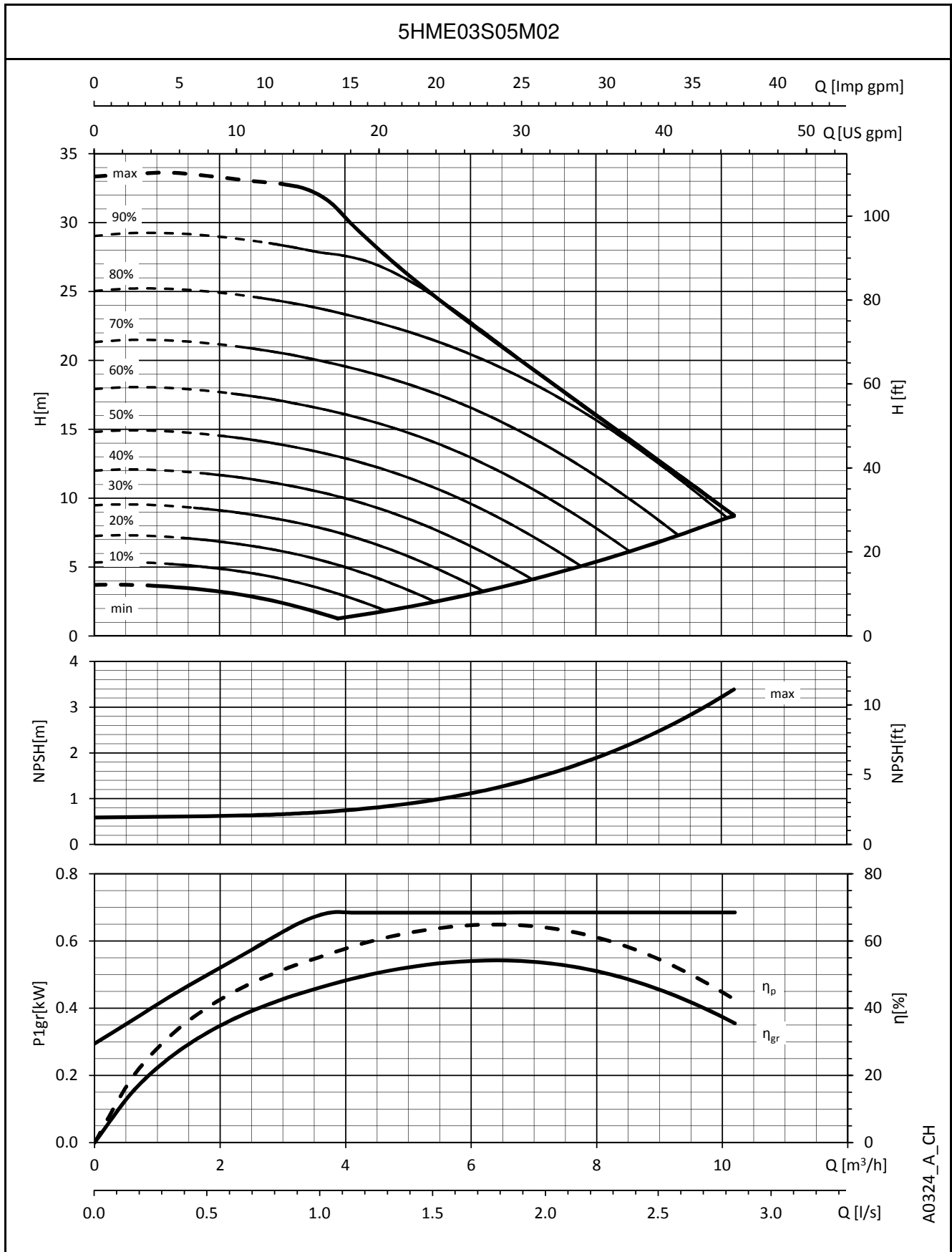

A0324_A_CH

The performances are valid for liquid with density $\rho = 1 \text{ Kg/dm}^3$ and kinematic viscosity $\nu = 1 \text{ mm}^2/\text{sec}$.

5HME..S SERIES OPERATING CHARACTERISTICS

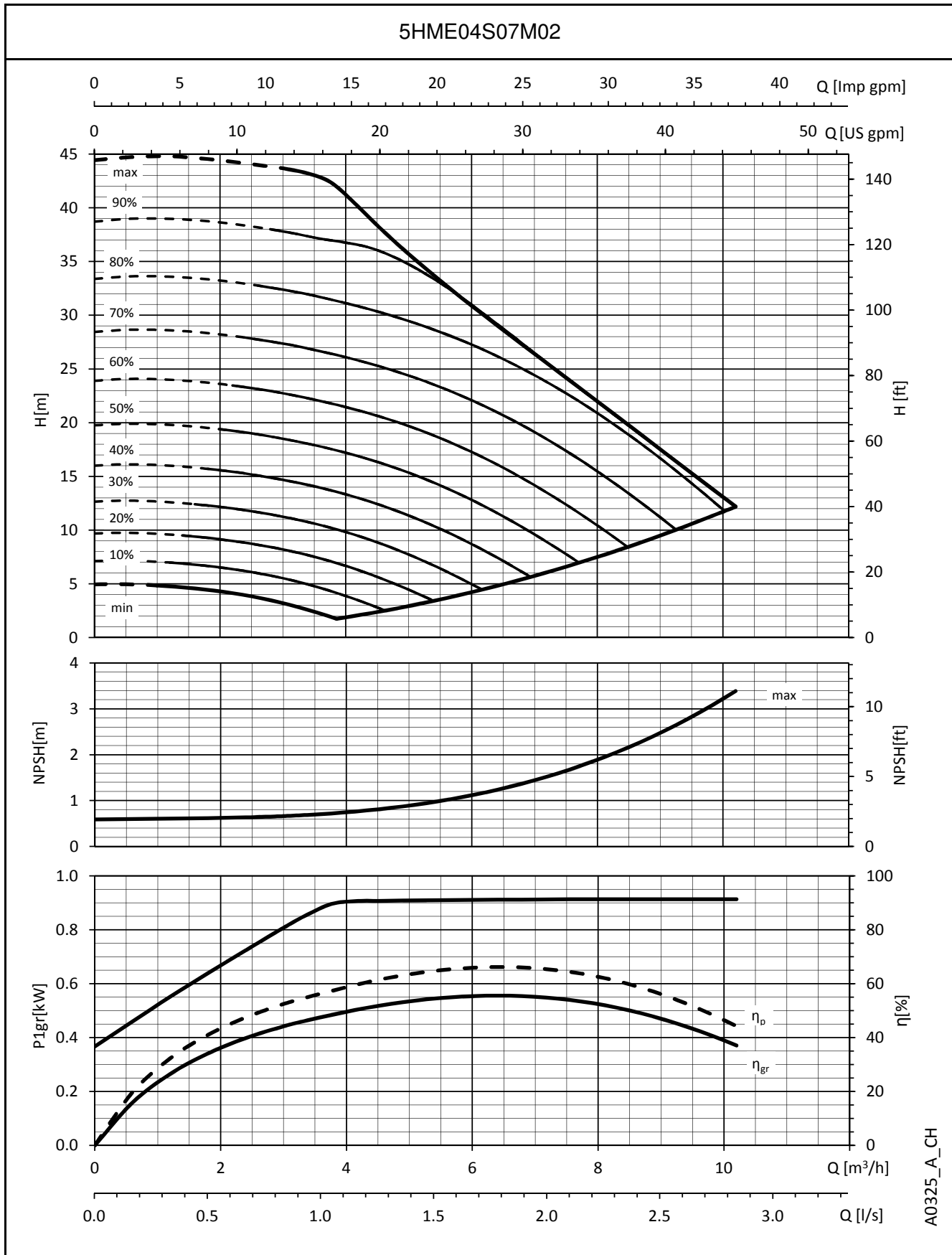

A0325_A_CH

The performances are valid for liquid with density $\rho = 1 \text{ Kg/dm}^3$ and kinematic viscosity $\nu = 1 \text{ mm}^2/\text{sec}$.

5HME..S SERIES OPERATING CHARACTERISTICS

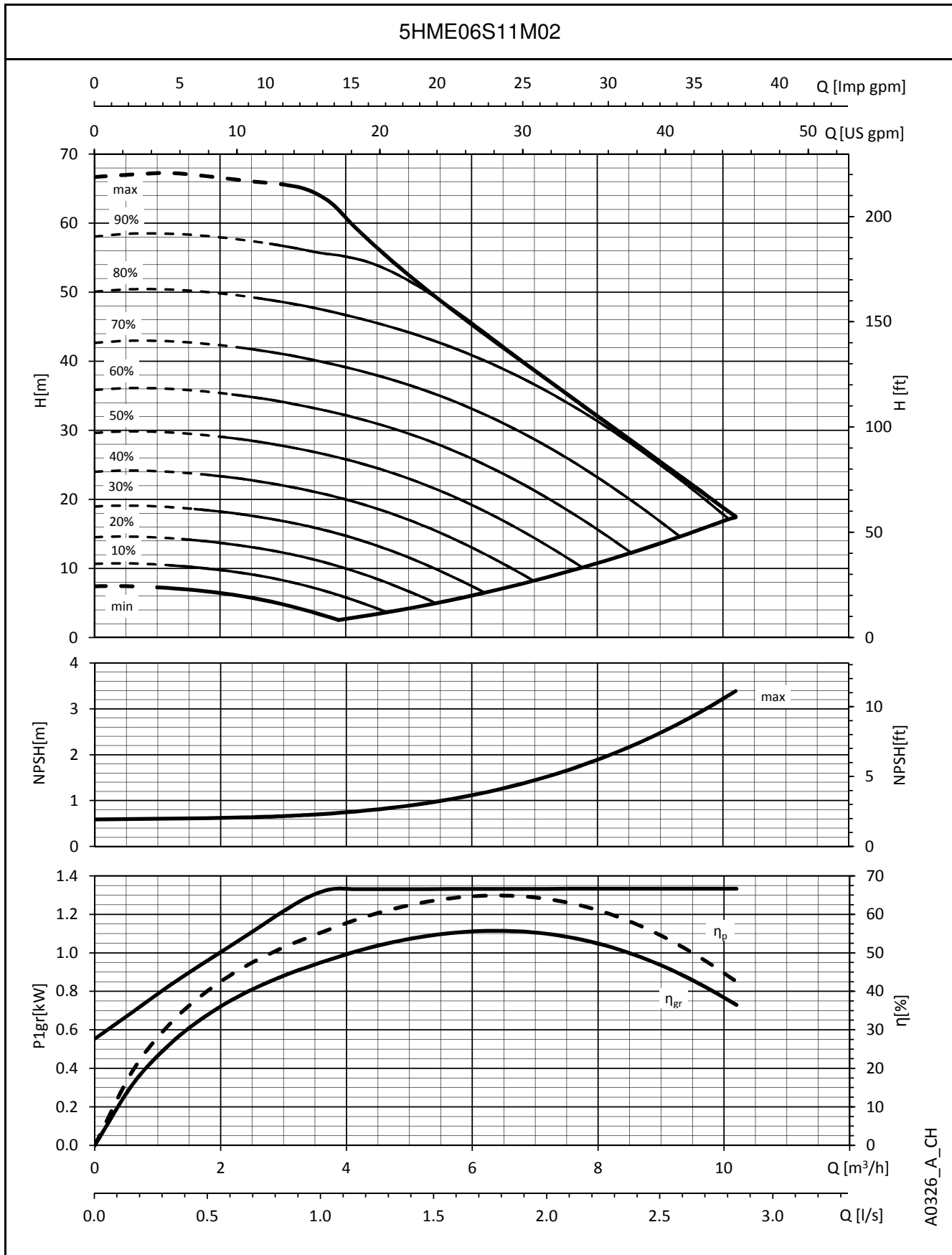

A0326_A_CH

The performances are valid for liquid with density $\rho = 1 \text{ Kg/dm}^3$ and kinematic viscosity $\nu = 1 \text{ mm}^2/\text{sec}$.

5HME..S SERIES OPERATING CHARACTERISTICS

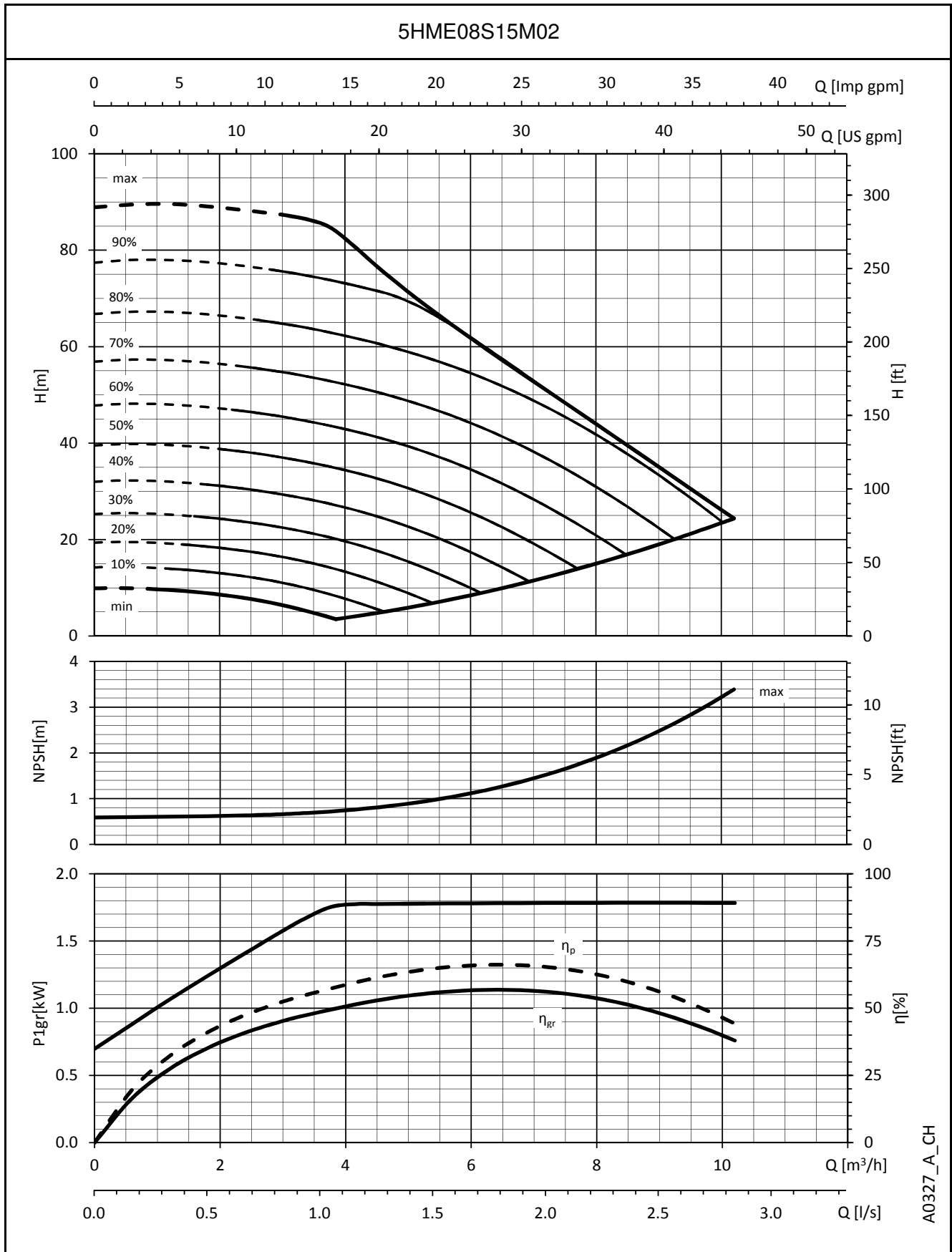

A0327_A_CH

The performances are valid for liquid with density $\rho = 1 \text{ Kg/dm}^3$ and kinematic viscosity $\nu = 1 \text{ mm}^2/\text{sec}$.

10, 15HME..S SERIES DIMENSIONS AND WEIGHTS

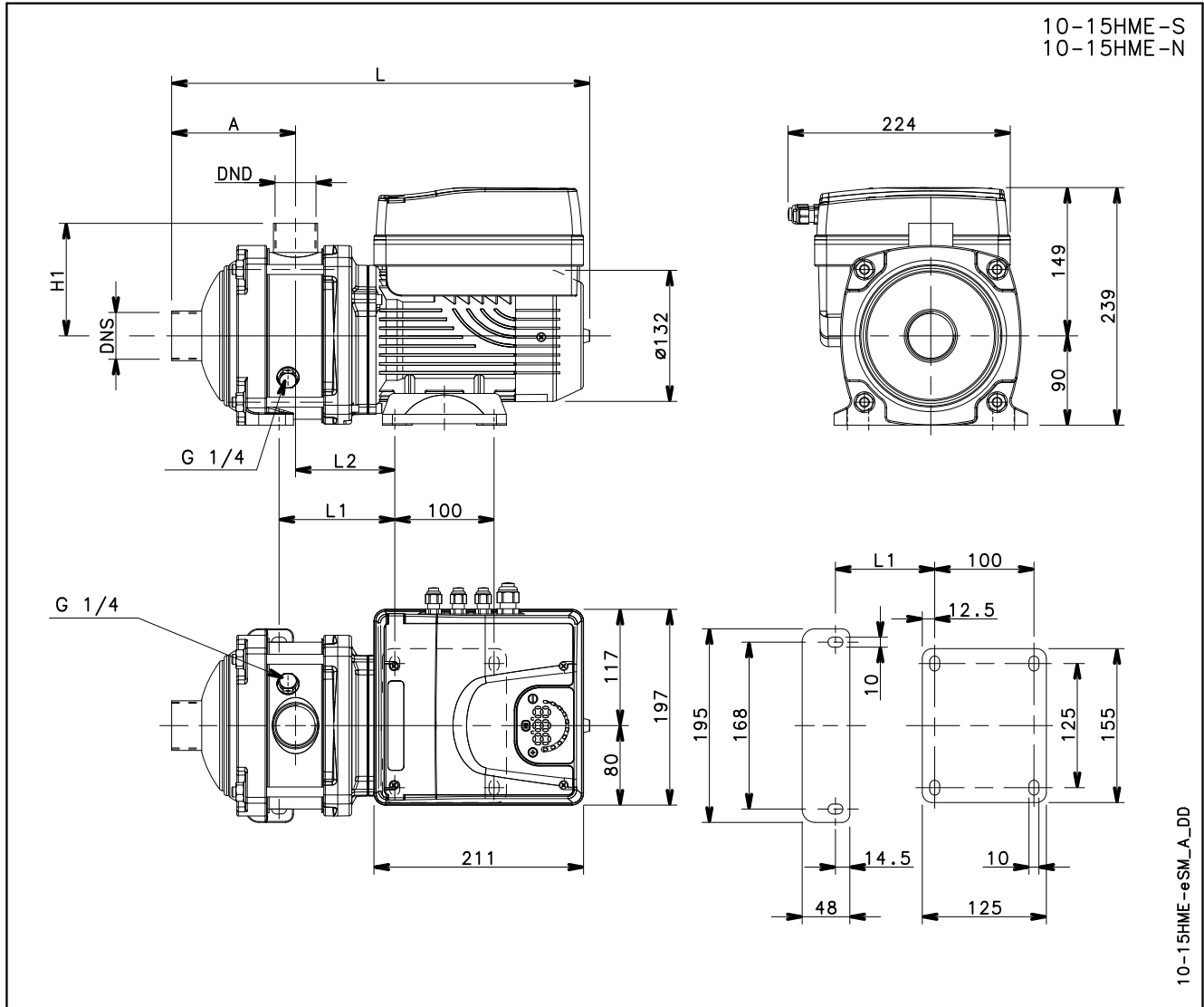

PUMP TYPE	VERSION	MOTOR		DIMENSIONS (mm)							PN	WEIGHT
		kw	SIZE	A	DND	DNS	H1	L	L1	L2		
10HME01S07M02	SINGLE-PHASE	0,75	80	125	Rp 1 1/4	Rp 1 1/2	113	422	116,5	100	10	12
10HME02S11M02		1,1	80	125	Rp 1 1/4	Rp 1 1/2	113	422	116,5	100	10	14
10HME03S15M02		1,5	80	125	Rp 1 1/4	Rp 1 1/2	113	422	116,5	100	10	14
15HME01S11M02		1,1	80	144	Rp 1 1/2	Rp 2	114	457	148,5	116	10	14
15HME02S15M02		1,5	80	144	Rp 1 1/2	Rp 2	114	457	148,5	116	10	14

10-15hmes-esm-2p50-en_a_td

10HME..S SERIES OPERATING CHARACTERISTICS

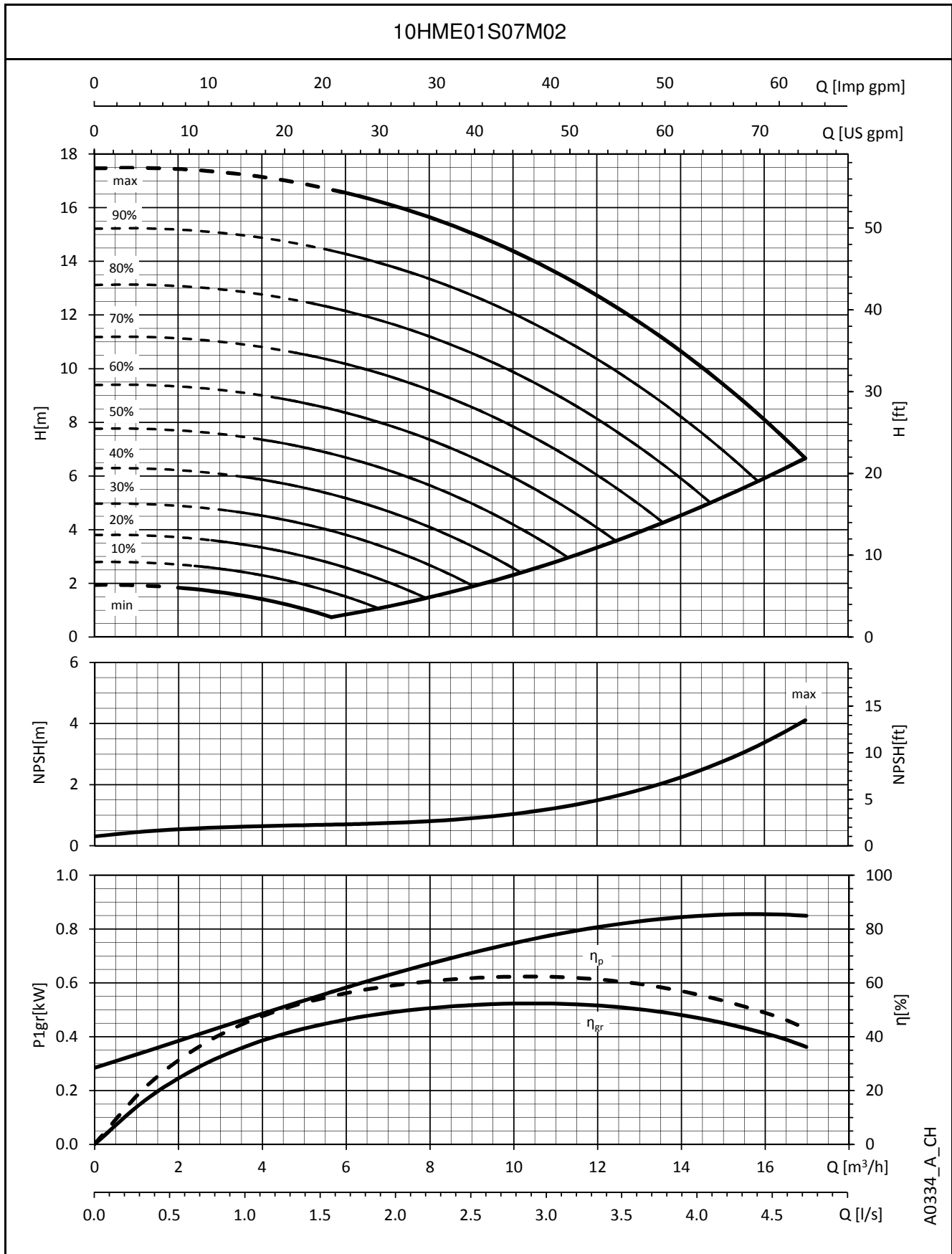

A0334_A_CH

The performances are valid for liquid with density $\rho = 1 \text{ Kg/dm}^3$ and kinematic viscosity $\nu = 1 \text{ mm}^2/\text{sec}$.

10HME..S SERIES OPERATING CHARACTERISTICS

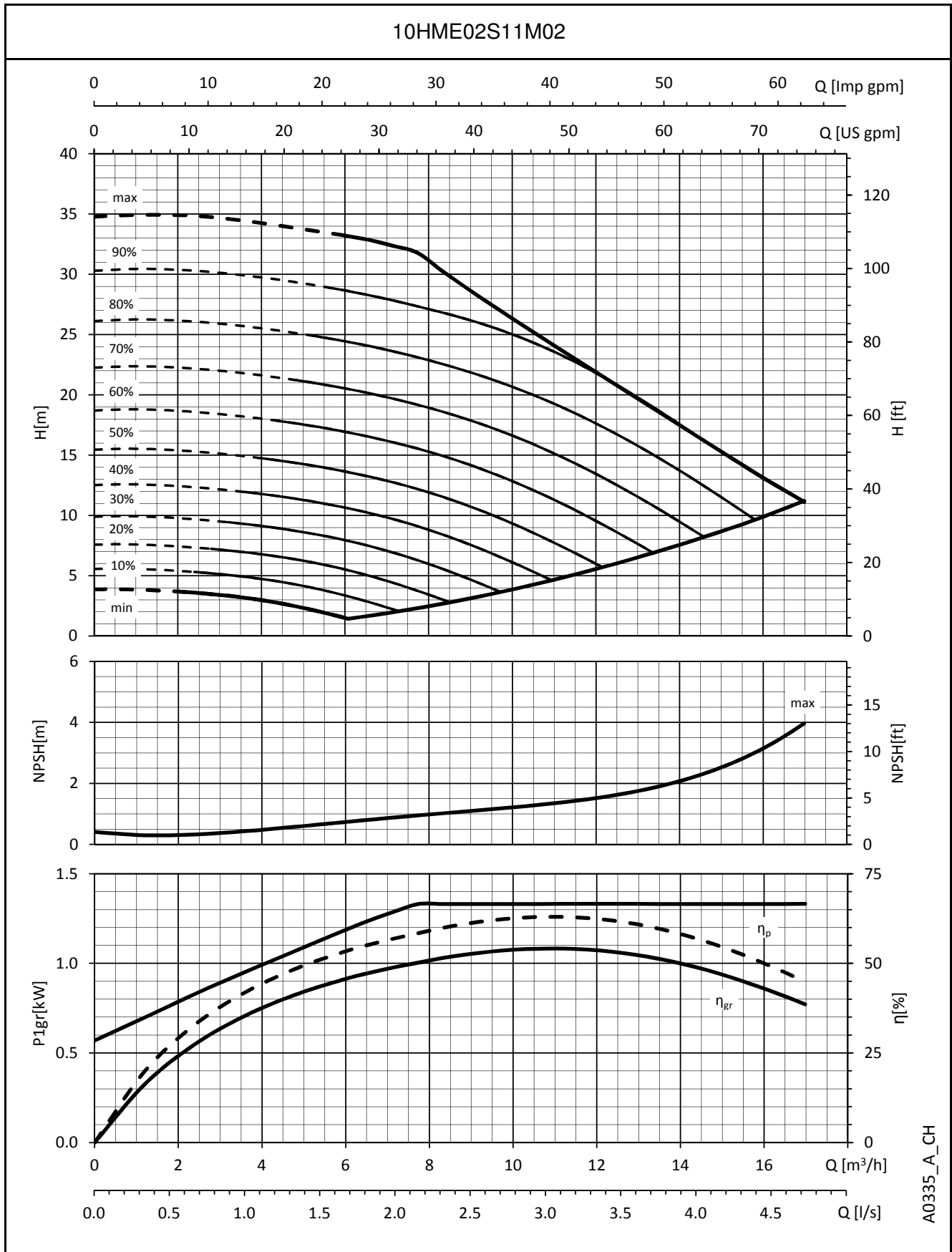

A0335_A_CH

The performances are valid for liquid with density $\rho = 1 \text{ Kg/dm}^3$ and kinematic viscosity $\nu = 1 \text{ mm}^2/\text{sec}$.

10HME..S SERIES OPERATING CHARACTERISTICS

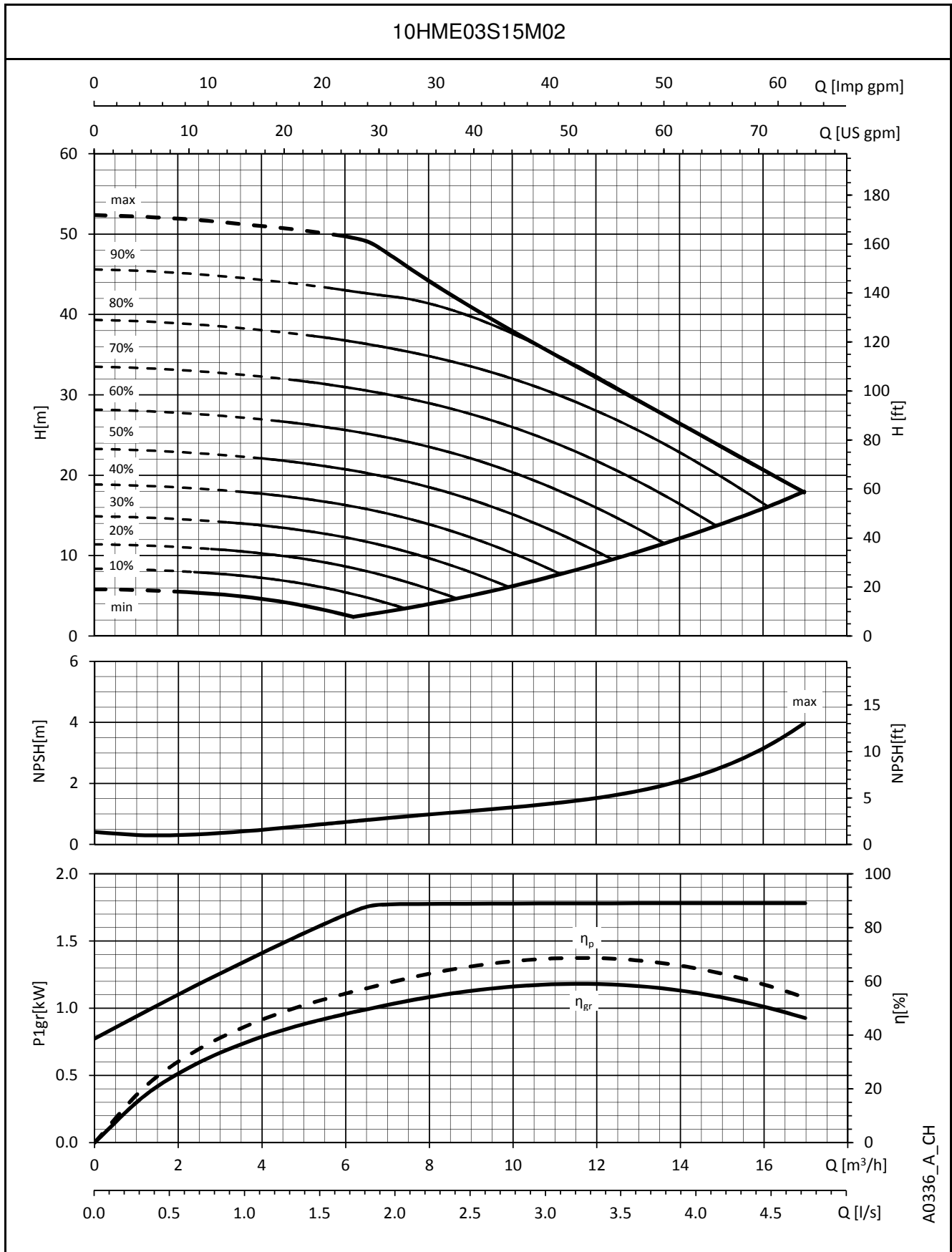

A0336_A_CH

The performances are valid for liquid with density $\rho = 1 \text{ Kg/dm}^3$ and kinematic viscosity $\nu = 1 \text{ mm}^2/\text{sec}$.

15HME..S SERIES OPERATING CHARACTERISTICS

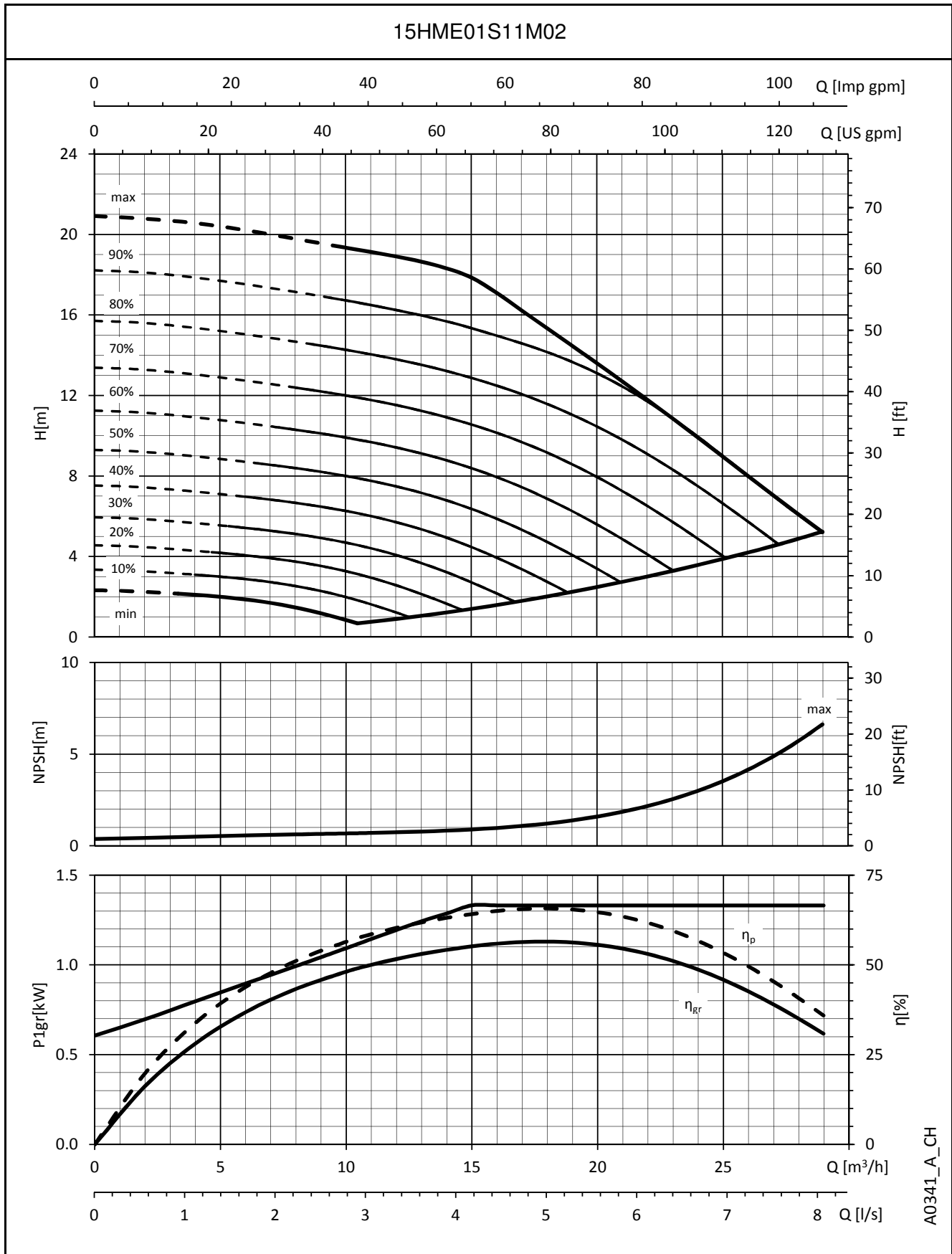

A0341_A_CH

The performances are valid for liquid with density $\rho = 1 \text{ Kg/dm}^3$ and kinematic viscosity $\nu = 1 \text{ mm}^2/\text{sec}$.

15HME..S SERIES OPERATING CHARACTERISTICS

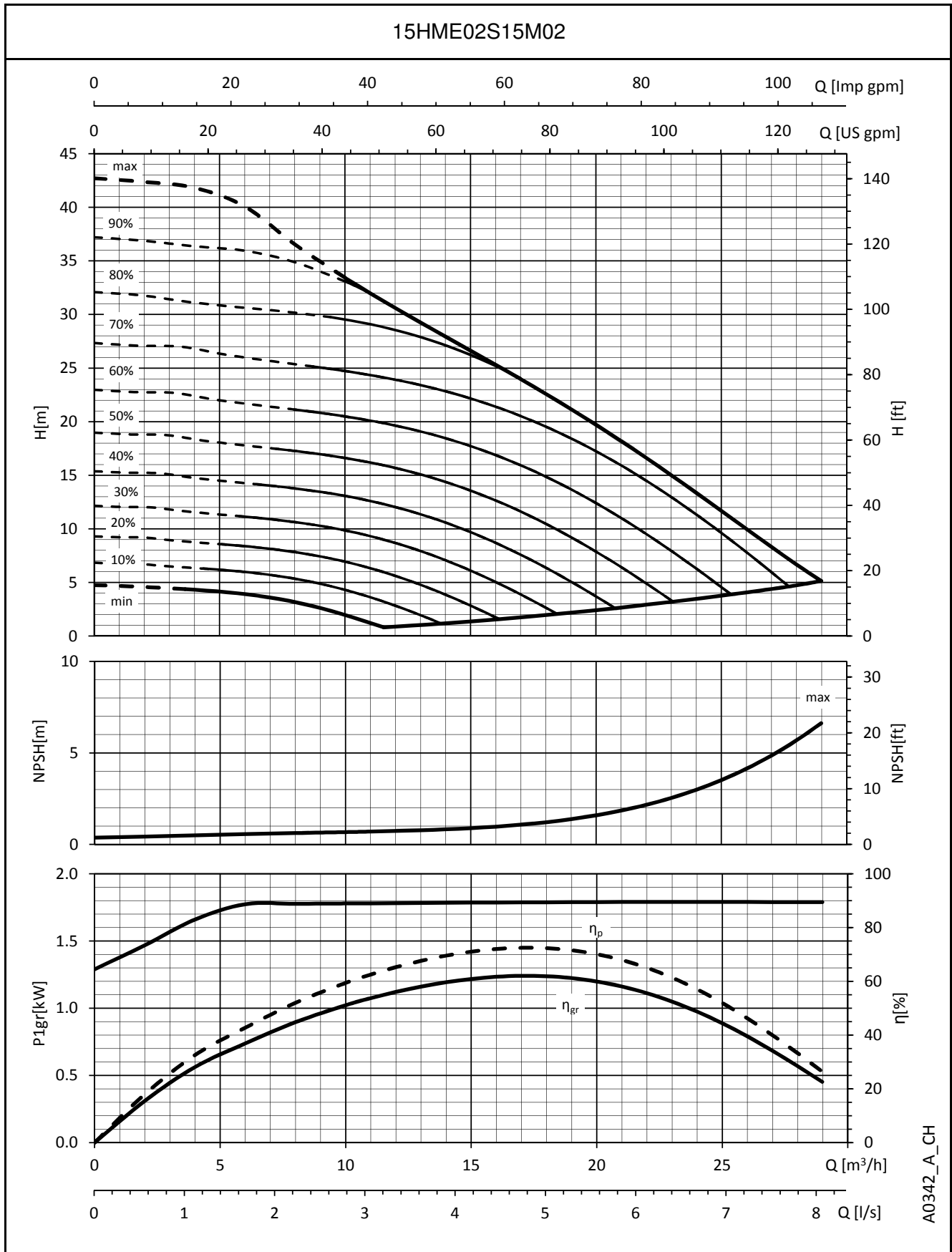

A0342_A_CH

The performances are valid for liquid with density $\rho = 1 \text{ Kg/dm}^3$ and kinematic viscosity $\nu = 1 \text{ mm}^2/\text{sec}$.

