

Superclamps 16-63mm

Product Code: Straight 01-08-116, Universal 01-08-117

Operating Instructions

REVISION: 01



Helping you make the right connections.

© **Copyright Caldervale Technology Ltd.**

The copyright for this product and instruction manual is held by Caldervale Technology Ltd. Any technical specifications, or illustrations part of this manual cannot be reproduced, used illicitly or distributed in any form for competitive purposes.

Contents

	Page
01. Introduction	02
02. Safety Instructions	03
03. Operation: Superclamp Straight	04
04. Operation: Superclamp Universal	06
05. Specifications: Superclamp Straight	07
06. Specifications: Superclamp Universal	09
07. Parts Diagram: Superclamp Straight	10
08. Parts Diagram: Superclamp Universal	11
09. Warranty Information	12
10. Service and Repair	14
11. Decommissioning and Disposal	14
Certificate of Conformity	15

01. Introduction

General Description

Superclamps are designed for restraining the movement of small diameter couplers for service installations. They are designed to fit pipe sizes from 16mm through to 63mm.

These tools are designed to clamp and hold pipe to provide stability and prevent movement primarily for electrofusion purposes with any polyethylene pipe material (new, weathered or previously installed) in accordance with Gas Industry Standards GIS/PL2-5 Part 5 Electrofusion Ancillary Tools.

This product (Superclamps) has been manufactured, inspected and tested in accordance with the ISO9001 quality control systems and procedures in place at Caldervale Technology Ltd, Dewsbury.

Before Using

It is important to ensure all component parts are present and in serviceable condition.

The condition of the tool should be inspected thoroughly prior to use.



Important!

This tool should be used in accordance with the pipe manufacturers' recommendations and in line with local codes of practice.

This manual outlines the operation of the pipe clamping tool for PE pipe and forms a part of the product to which it relates. It should be kept for the life of the product. Any amendments issued by Caldervale Technology Ltd should be incorporated in the text. The manual should be passed to any subsequent holder or user of this product.

02. Safety Instructions

1. Read and understand the whole booklet before using the tool.
2. It is imperative that all possible precautions are made to avoid unexpected movement of the tool and pipe during use.
3. Never attempt to operate on pipes that are not within the specified dimensions.
4. Operatives should wear eye protection, gloves, safety headwear & footwear when using the equipment.

03. Operation: Superclamp Straight

Instructions for Use

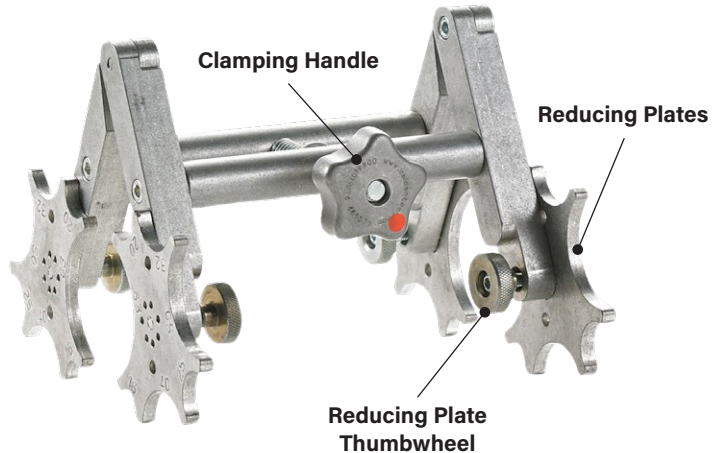

1. Check the pipe size and select the correct side of the reducing plates.
2. If required change the orientation of the reducing plates by turning the reducing plate thumbwheel fully anticlockwise, pull the reducing plate and turn until the correct size cut out is between the jaws. Note; if using a reducing coupler different shells can be used at either side of the clamp.
3. Push the reducing plate back into place (there is a pin which prevents incorrectly locating the plate in place) and turn the thumbwheel fully clockwise.
4. Repeat step 2 and 3 for all 4 reducing plates.
5. Turn clamping handle anticlockwise to open the jaws wide enough for the pipe being clamped.
6. Place the clamp over the pipe and/or fitting to be clamped (fitting should be between the arms if used).

7. Turn clamping handle clockwise to tighten the clamp onto the pipes and ensure it is tight and does not allow for movement or sliding of the pipes.

Removal

To remove the clamp, turn the clamping handle anticlockwise until the jaws are wide enough to allow the clamp to be removed from the pipe.



Storage

IMPORTANT! When not in use always:

1. Store the tool in the carry case provided.
2. Ensure the tool is clean and dry before storage.

Routine Maintenance

1. Check for correct movement and operation and lubricate moving parts at regular intervals before using.
2. It is important to ensure all component parts are present and in serviceable condition.

04. Operation: Megaclamp Universal

Instructions for Use

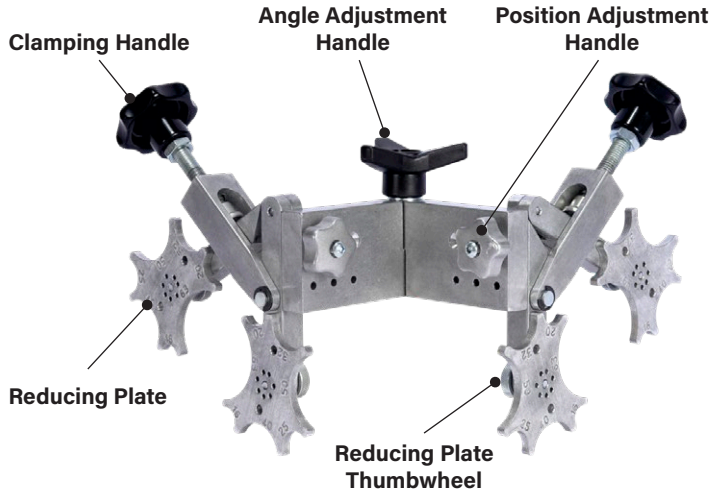

1. Check the pipe size and select the correct side of the reducing plates.
2. If required change the orientation of the reducing plates by turning the reducing plate thumbwheel fully anticlockwise, pull the reducing plate and turn until the correct size cut out is between the jaws. Note; if using a reducing coupler different shells can be used at either side of the clamp.
3. Push the reducing plate back into place (there is a pin which prevents incorrectly locating the plate in place) and turn the thumbwheel fully clockwise.
4. Repeat step 2 and 3 for all reducing plates.
5. The position of the clamping jaws can be changed by turning the position adjustment handle anticlockwise, moving the jaws to the desired position.

6. The angle of the clamp can also be adjusted, this is done by turning the angle adjustment handle anticlockwise and moving the separate body parts up and down to separate them.
7. Turn the body pieces to the desired angle and push the parts of the body together to allow the locating pins to slot into the locating holes and tighten the angle adjustment handle clockwise.
8. Turn both clamping handles anticlockwise to open the jaws wide enough for the pipe being clamped.
9. Place the clamp over the pipe and/or fitting to be clamped (fitting should be between the arms if used).
10. Turn both clamping handles clockwise to tighten the clamp onto the pipes and ensure it is tight and does not allow for movement or sliding of the pipes.

Removal

To remove the clamp, turn the clamping handles anticlockwise until the jaws are wide enough to allow the clamp to be removed from the pipe.



Storage

IMPORTANT! When not in use always:

1. Ensure the tool is clean and dry before storage.

Routine Maintenance

1. Check for correct movement and operation and lubricate moving parts at regular intervals before using.
2. It is important to ensure all component parts are present and in serviceable condition.

05. Specifications: Superclamp Straight

Materials:	Mild Steel / Stainless Steel / Aluminium / Plastic
Dimensions:	200mm x 200mm x 165mm
Weight:	1.1kg
Min pipe Diameter:	16mm
Max pipe Diameter:	63mm
Product Code:	01-08-116

This unit is designed and manufactured to meet the requirements of National Grid Gas Industry Standards GIS/PL2-5 Part 5 Electrofusion and Ancillary Tooling.

Caldervale Technology Ltd has a policy of continuous improvement in product quality and design. Caldervale Technology Ltd therefore reserves the right to change the specification of its models at any time, without prior notice.

It is the responsibility of the operator to ensure that the PE pipe is suitable for this clamping system if in doubt contact the PE pipe manufacturer for confirmation.

06. Specifications: Superclamp Universal

Materials:	Mild Steel / Stainless Steel / Aluminium / Plastic
Dimensions:	260mm x 200mm x 195mm
Weight:	2.15kg
Min pipe Diameter:	16mm
Max pipe Diameter:	63mm
Product Code:	01-08-117

This unit is designed and manufactured to meet the requirements of National Grid Gas Industry Standards GIS/PL2-5 Part 5 Electrofusion and Ancillary Tooling.

Caldervale Technology Ltd has a policy of continuous improvement in product quality and design. Caldervale Technology Ltd therefore reserves the right to change the specification of its models at any time, without prior notice.

It is the responsibility of the operator to ensure that the PE pipe is suitable for this clamping system if in doubt contact the PE pipe manufacturer for confirmation.

07. Parts Diagram: Superclamp Straight

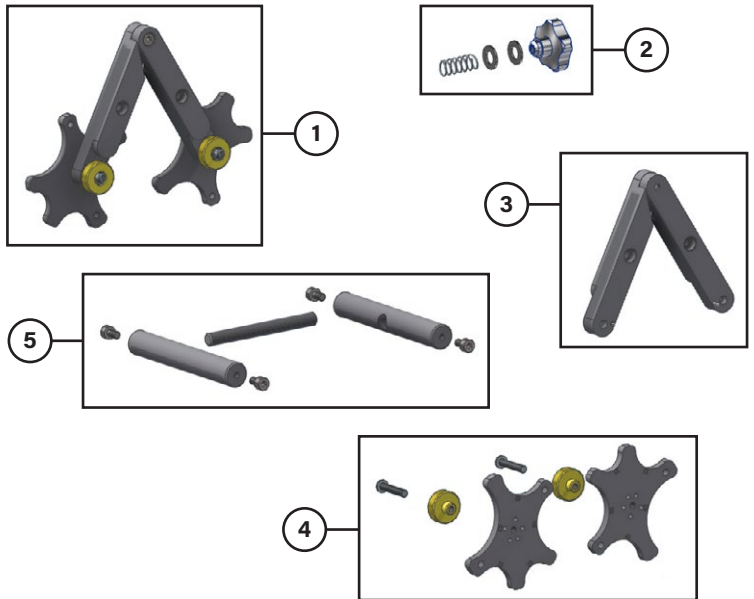

Part	Product Code	Description
1	TBC	Complete Leg Assembly
2	TBC	Leg Clamping Handle
3	TBC	Leg Assembly
4	TBC	Reducing Plates Repair Kit
5	TBC	Body

08. Parts Diagram: Superclamp Universal

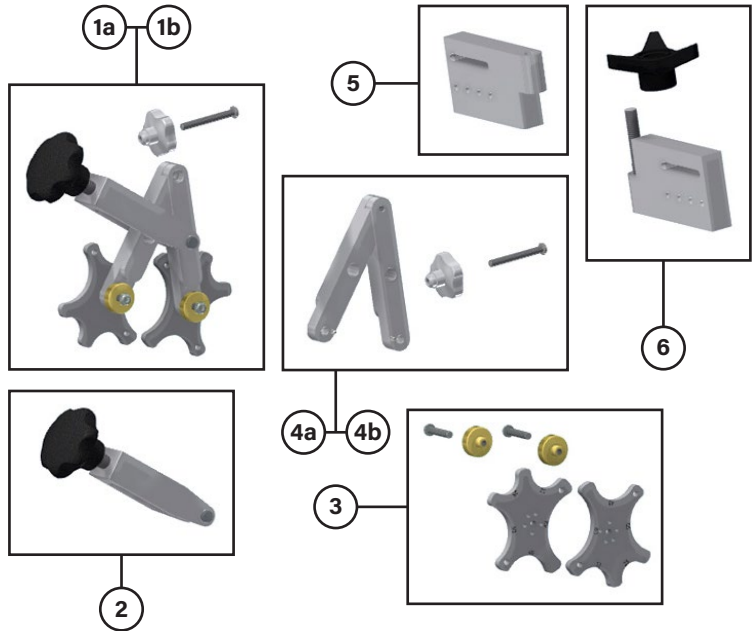

Part	Product Code	Description
1a	TBC	Left Hand Complete Leg Assembly
1b	TBC	Right Hand Complete Leg Assembly
2	TBC	Leg Clamping Handle
3	TBC	Reducing Plates Repair Kit
4a	TBC	Left Hand Leg Assembly
4b	TBC	Right Hand Leg Assembly
5	TBC	Left hand Body Piece
6	TBC	Right Hand Body Piece
7	TBC	Handles Repair Kit

09. Warranty Information

1. Extent of Warranty

- a) Subject to clauses 2 and 3, Caldervale Technology Ltd warrants to the end-user customer that its products will be free from defects in materials and workmanship, for six months after the date of purchase by the end-user customer, subject to providing proof of purchase.
- b) If Caldervale Technology Ltd receives, during the warranty period, notice of a defect in product which is covered by this warranty; Caldervale Technology Ltd shall either repair or replace the product, at its option. Any replacement product may be either new or like-new, provided that it has functionality at least equal to that of the product being replaced.
- c) All warranty work will be carried out by Caldervale Technology Ltd unless otherwise agreed. On-site warranty and repair or replacement services are available from authorised Caldervale Technology Ltd service facilities world-wide.
- d) Customers shall prepay shipping charges for products returned to Caldervale Technology Ltd for warranty service, and Caldervale Technology Ltd will charge for return of the products back to the customer.
- e) This warranty statement gives the customer specific legal rights. The customer may also have other rights which vary from country to country in the world.

2. Pre-conditions for Warranty Application

Caldervale Technology Ltd's warranty covers only those defects which arise as a result of normal use of the product, and this warranty shall only apply in the following circumstances:

- a) All the instructions contained in the operating manual have been complied with; and
- b) None of the following apply:
 - i) Improper or inadequate maintenance;
 - ii) Physical abuse;
 - iii) Unauthorised modification, misuse or any use not in accordance with the operating manual and good industry practice;

- iv) Operation outside the products specifications;
- v) Improper site preparation or maintenance;
- vi) Faulty pipes.

3. Limitations of Warranty

- a) Caldervale Technology Ltd does not warrant the operation of any product to be uninterrupted or error free.
- b) Caldervale Technology Ltd makes no other warranty of any kind, whether express or implied, with respect to its products. Caldervale Technology Ltd specifically disclaims the implied warranties of satisfactory quality and fitness for a particular purpose.
- c) To the extent that this warranty statement is inconsistent with the law of the locality where the customer uses the product, this warranty statement shall be deemed modified by the minimum necessary to be consistent with such local law.
- d) To the extent allowed by local law, the remedies provided in this warranty statement are the customer's sole and exclusive remedies.
- e) This tool has been designed for the range of pipes available at the time of its design and development. Caldervale Technology Ltd can accept NO liability for the unit's ability or otherwise to work with new or different pipes that subsequently appear in the market place.

Please complete this information and keep it safely with your proof of purchase receipt. You will require it for any warranty claim.

Where purchased: _____

Date of purchase: _____

Name of purchaser: _____

Address of purchaser: _____

Type of tool: _____

Serial number: _____

10. Service and Repair

This product has no specific calibration period, however periodic safety inspections should be carried out by the operator as specified in this manual, if in any doubt please contact the manufacturer for further information.

INTERNATIONAL

Caldervale Technology Ltd

Bretfield Court, Dewsbury,
West Yorkshire WF12 9BG, UK

T. +44 (0)1924 469571

E. sales@caldertech.com

W. caldertech.com

AUSTRALIA / NZ

Caldertech Australia Pty Ltd

Unit 3/30 Juna Drive,
Malaga WA 6090, Australia

T. +61 (0)8 9209 1132

E. sales@caldertech.com.au

W. caldertech.com.au

11. Decommissioning and Disposal

These give the instructions for decommissioning and disposal of the equipment and confirm how it is to be taken out of service safely, in respect of the Essential Environmental, Health and Safety Requirements.

- If a Caldertech Superclamp has reached the end of its useful working life and cannot be refurbished it must be sent to a licensed recycling facility for treatment. That will ensure the waste hierarchy requirements are met.
- End of life treatment is the responsibility of the Customer. This can also be achieved by returning the product back to the manufacturer if required.



Certificate of Conformity

This document certifies that the product detailed below fully conforms to the following standard without derogation.

GIS/PL2-5:2018 Electrofusion Ancillary Tools

Product: Superclamps

MARCH 2019



I. Smith
Managing Director



Caldervale Technology Ltd
Bretfield Court, Dewsbury, West Yorkshire WF12 9BG, UK
CRN 2769288 | ISO 9001:2015 Certified FM 30989



INTERNATIONAL

Caldervale Technology Ltd

Bretfield Court, Dewsbury,
West Yorkshire WF12 9BG, UK

T. +44 (0)1924 469571

E. sales@caldertech.com

W. caldertech.com

AUSTRALIA / NZ

Caldertech Australia Pty Ltd

Unit 3/30 Juna Drive,
Malaga WA 6090, Australia

T. +61 (0)8 9209 1132

E. sales@caldertech.com.au

W. caldertech.com.au



Caldertech
.com