

ENCLOSURE PLAN VIEW 1

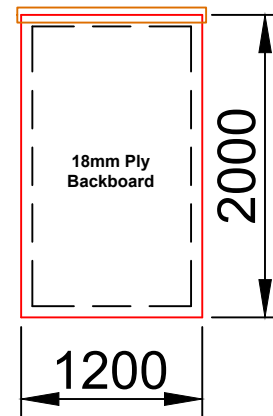

ENCLOSURE REAR VIEW 4

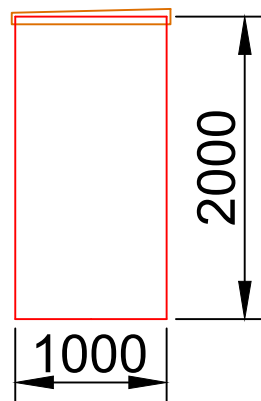

**EXTERNAL ELEVATION WALL 2
(SIDE WALL)**

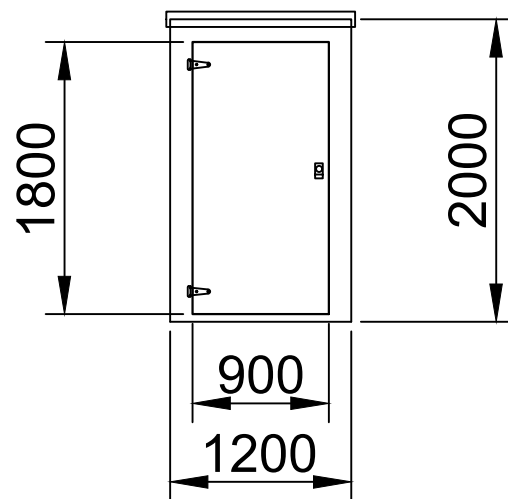

**EXTERNAL ELEVATION WALL 1
(FRONT WALL)**

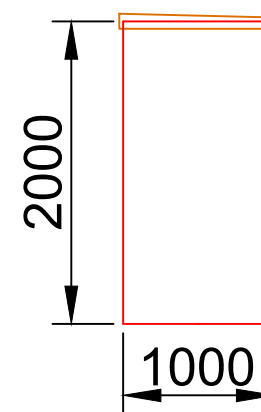

**EXTERNAL ELEVATION WALL 3
(SIDE WALL)**

Typical Stepped Concrete Base Detail (Recommended)

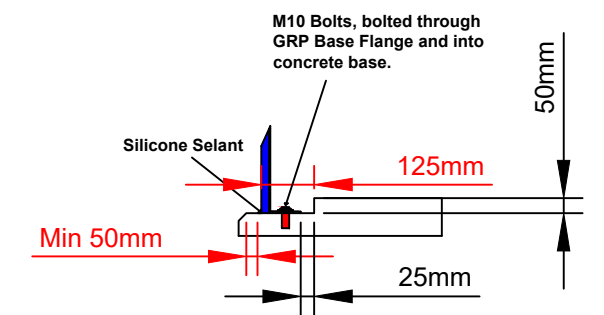

NOTES:

DOUBLE DOOR:

- 1no. 900mm Wide x 1800mm High
- 2no. Stainless Steel Hinges
- 2no. Stainless Steel Spring Tower Bolts
- 1no. Stainless Steel Hasp & Staple

BACKBOARD:

- 1no. 18mm Ply Surface Treated Backboard

		<i>External Finish:</i> Semi-Gloss: Smooth		<i>Internal Color:</i> White		<i>External Color:</i> Green (14-C-39)	
		<i>Fire Resistance:</i> BS476 Part 22- 1/2 hr.		<i>Base Flange:</i> 100mm GRP Base Flange		<i>Roof Construction:</i> Single Skin GRP	
DWG #	DT6	Rev		Date	22-09-16	Scale	N/A
		<i>Doors:</i> 1no. Single Door 900mm x 1800mm (H)		<i>Ventilation:</i>		<i>Wall Construction:</i> Single Skin GRP	