

External Elevation  
WALL 3

**Typical Stepped Concrete Base Detail (Recommended)**

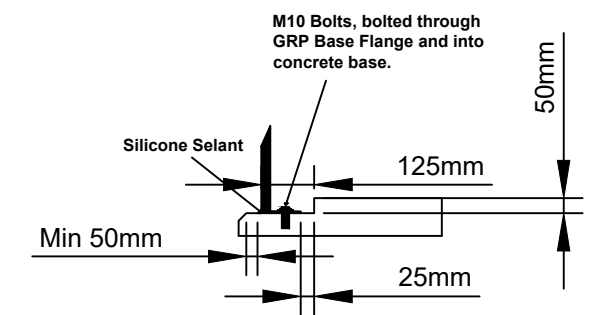

**NOTES:**

- DOUBLE DOOR:**  
 1no. 1760mm Wide x 1760mm High Clear Opening  
 4no. Stainless Steel Hinges  
 2no. Stainless Steel Spring Tower Bolts  
 1no. Cylinder Night Latch Lock or Hasp & Staple

**OPTIONAL EXTRAS**

- SINGLE SKIN FLOOR  
 LOAD BEARING FLOOR  
 CAT FLAP  
 ELECTRICS  
 VENTS

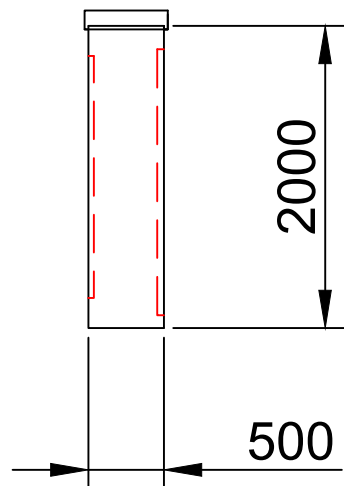

External Elevation  
WALL 2

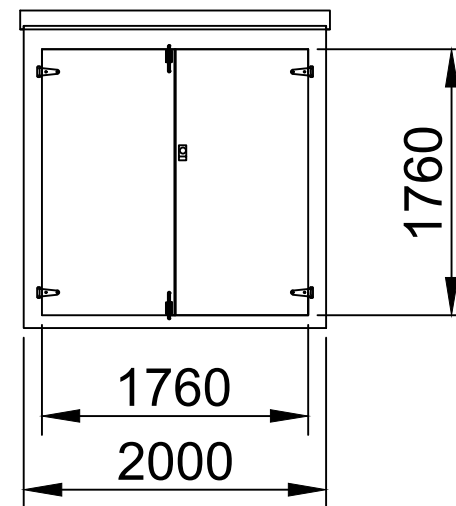

External Elevation  
WALL 1

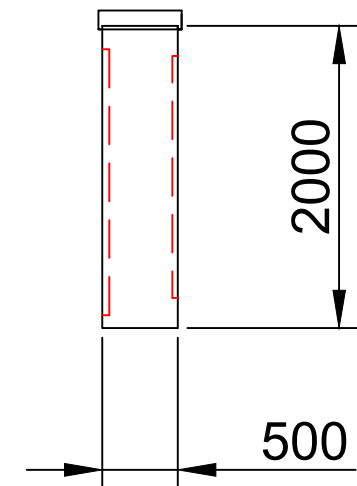

External Elevation  
WALL 4

		<i>External Finish:</i> SEMI GLOSS		<i>Internal Color:</i> White		<i>External Color:</i> T.B.C	
		<i>Fire Resistance:</i> BS476 Part 22- 1/2 hr.		<i>Base Flange:</i> 100mm GRP Base Flange		<i>Roof Construction:</i> GRP	
<b>DWG #</b>	WT1	<b>Rev</b>		<b>Date</b>	27/07/20	<b>Scale</b>	N/A
		<i>Doors:</i> 1no. Double Door 1760mm x 1760mm (H)		<i>Ventilation:</i>		<i>Wall Construction:</i> GRP	