

Installation, Operation and
Maintenance Instructions

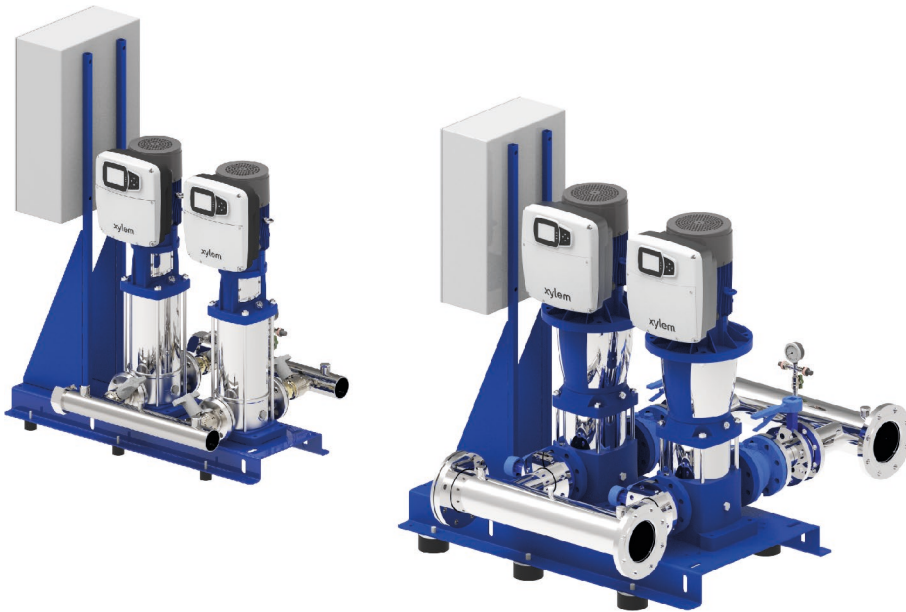

GHV SVX Series

Pump set with integrated variable
speed drive

Applicare qui l'adesivo con il codice a barre

Apply the adhesive bar code nameplate here

Table of Contents

- 1 Introduction and Safety 5
 - 1.1 Introduction 5
 - 1.2 Hazard levels and safety symbols..... 5
 - 1.3 User safety 6
 - 1.4 Safety devices..... 7
 - 1.5 "Pump set off" status..... 7
 - 1.6 Protection of the environment..... 7
- 2 Handling and Storage..... 9
 - 2.1 Inspect the delivery 9
 - 2.1.1 Package inspection 9
 - 2.1.2 Unpacking and inspection of the pump set..... 9
 - 2.2 Guidelines for transport..... 9
 - 2.2.1 Handling with forklift..... 10
 - 2.2.2 Lifting with a crane 11
 - 2.3 Storage 14
- 3 Product Description 16
 - 3.1 Features 16
 - 3.1.1 Use in water distribution networks for human consumption 16
 - 3.1.2 Part names..... 17
 - 3.2 Data plates..... 20
 - 3.3 Identification code 21
- 4 Installation 22
 - 4.1 Precautions 22
 - 4.2 Mechanical installation..... 24
 - 4.3 Hydraulic connection 26
 - 4.3.1 Protection against dry running 28
 - 4.4 Guidelines for electrical connection..... 29
 - 4.5 Guidelines for the control panel..... 30
 - 4.5.1 Ground fault circuit interrupter, GFCI 31
 - 4.6 Guidelines for the drive: GHV10 32
 - 4.6.1 Positioning..... 32
 - 4.6.2 Power supply connection..... 32
- 5 Control..... 34
 - 5.1 Description of the drive display..... 34
 - 5.1.1 Graphic display..... 35
 - 5.1.2 Parameters menu 36
 - 5.1.3 Electric pump start using the drive display 36
 - 5.1.4 Operating mode change 36

5.1.5	Error reset	37
5.2	Xylem X App.....	37
6	Use and Operation.....	39
6.1	Precautions	39
6.2	Filling and priming	40
6.3	First commissioning	40
6.4	Manual stop	42
7	Maintenance.....	43
7.1	Precautions	43
7.2	Maintenance every 3 months	44
7.3	Maintenance every 4000 hours of operation, or every year	44
7.4	Maintenance every 10000 hours of operation or every 2 years	44
7.5	Maintenance every 17500 hours of operation or every 5 years	44
7.6	Long periods of inactivity.....	45
7.7	Identification of spare parts.....	45
8	Troubleshooting.....	46
8.1	The control panel does not switch on	46
8.2	The control panel protection device trips.....	46
8.3	The protection device has tripped	46
8.4	The drive display does not switch on	47
8.5	The electric pump does not start automatically.....	47
8.6	The pump set starts and stops too frequently	47
8.7	The motor speed varies frequently but the liquid is not pumped	47
8.8	The electric pump works but the liquid is not pumped	47
8.9	The electric pumps are leaking	48
8.10	The pump set produces excessive noise and/or vibrations	48
8.11	The electric pump is leaking at the mechanical seal	48
8.12	The electric pump does not stop when the setpoint is reached.....	48
8.13	The pump set does not generate the required pressure	49
8.14	The electric pump runs at maximum speed without stopping	49
8.15	Only one electric pump of the multi-pump set is working.....	49
8.16	The electric pump does not start with the liquid demand	49
8.17	The piping system does not prime	50
8.18	Pump set error or alarm	50
9	Specifications	51
9.1	Operating environment	51
9.2	Liquid temperature	51
9.3	Maximum operating pressure of the electric pumps	52
9.4	Maximum number of starts per hour.....	52
9.5	Electrical specifications	52
9.6	Radio frequency characteristics.....	53
9.7	Characteristics of inputs and outputs.....	53

9.8	Sound pressure	53
10	Disposal	54
10.1	Precautions	54
10.2	WEEE (EU/EEA)	54
10.3	WEEE (UK)	54
11	Declarations.....	55
12	Warranty	58

1 Introduction and Safety

1.1 Introduction

Purpose of this manual

This manual provides information on how to do the following in the correct manner:

- Installation
- Operation
- Maintenance.



ATTENTION:

This manual is an integral part of the pump set. Before installing and using the pump set, make sure that you have read and understood this manual. This manual must always be made available to the user, stored in the proximity of the pump set and well kept.

Supplementary instructions



The instructions and warnings of this manual apply to the standard pump set as described in the commercial documentation. Special version pumps may be supplied with supplementary instruction manuals. For situations not considered in the manual or in the commercial documentation, contact Xylem or the Authorised Distributor.

1.2 Hazard levels and safety symbols







Before using the pump set, and in order to avoid the following risks, make sure that you carefully read, understand and comply with the below danger warnings:

- Injuries and health hazards
- Damage to the product
- Pump set malfunction.

Hazard levels

Hazard level	Indication
 DANGER:	It identifies a dangerous situation which, if not avoided, causes serious injury, or even death.
 WARNING:	It identifies a dangerous situation which, if not avoided, may cause serious injury, or even death.
 ATTENTION:	It identifies a dangerous situation which, if not avoided, may cause small or medium level injuries.
NOTE:	It identifies a situation which, if not avoided, may cause damage to property but not to people.

Complementary symbols

Symbol	Description
	Electrical hazard
	Hot surface hazard
	Explosive atmosphere hazard
	Ionizing radiation hazard
	Magnetic hazard
	Cutting hazard
	Do not use flammable liquids

1.3 User safety

Strictly comply with current health and safety regulations.

Qualified personnel

This pump set must only be used by qualified personnel. Qualified personnel means individuals capable of recognising the risks and avoid hazards during the installation, use and maintenance of the pump set.

Personal protective equipment

During the handling, installation, use and maintenance of the pump set, always use the following personal protective equipment:

- Overalls
- Helmet
- Safety gloves for protection against mechanical and chemical hazards
- Safety shoes with reinforced toe caps
- Safety goggles

1.4 Safety devices



WARNING:

It is forbidden to modify, disable or remove any safety devices in full or in part.



WARNING:

Regularly check the operation of all the safety devices.



WARNING:

Replace any defective and/or damaged safety devices using original spare parts.

The figure shows the safety devices of the pump set.

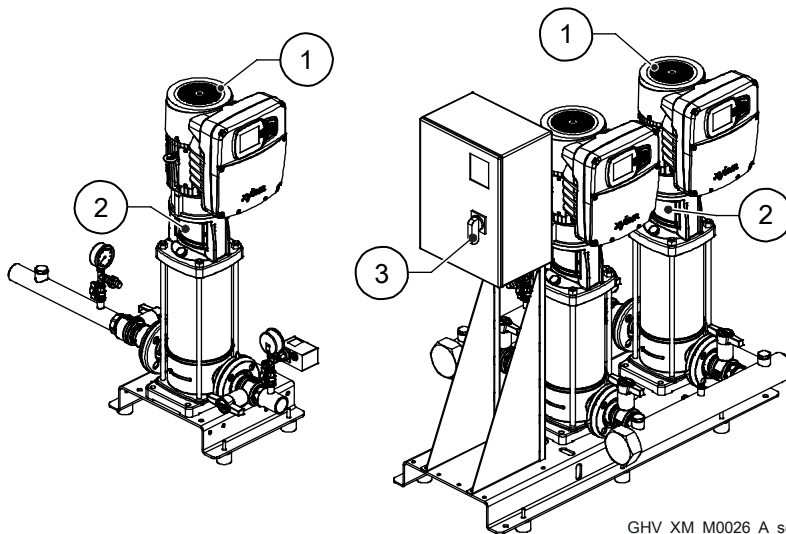

GHV_XM_M0026_A_sc

1. Fan cover
2. Coupling or coupling guard protection, depending on the type of electric pump
3. Main control panel electric switch, if fitted

1.5 "Pump set off" status

Turn the main switch of the control panel to 0-OFF to disconnect the electric power supply source.



WARNING: Electrical hazard

If the pump set does not have a control panel with a main electric switch, install an equivalent device to disconnect the electric power supply source.

1.6 Protection of the environment

Disposal of packaging and product

Comply with the current laws on sorted waste disposal, see **Disposal** on page 54.

Leaking of fluid

Depending on the model, the pump set may contain lubricant oil. Implement the necessary measures to prevent the dispersion of any liquids in the environment.

Sites exposed to ionizing radiations



WARNING: Ionizing radiation hazard

If the pump set has been exposed to ionizing radiations, implement the necessary safety measures for the protection of people. When shipping the pump set, inform the carrier and the recipient accordingly, so that appropriate safety measures can be put in place.

2 Handling and Storage

2.1 Inspect the delivery

2.1.1 Package inspection

1. Check that quantity, descriptions and product codes match the order.
2. Check the packaging for any damage or missing components.
3. In case of immediately detectable damage or missing parts:
 - Accept the goods with reserve, indicating any findings on the transport document, or
 - Reject the goods, indicating the reason on the transport document.
 In both cases, contact Xylem or the Authorised Distributor from whom the product was purchased.

2.1.2 Unpacking and inspection of the pump set



ATTENTION: Cut and abrasion hazard

Always wear personal protective equipment.

1. Remove the packaging.
2. Ensure sorting of all packaging materials in accordance with the applicable regulations.
3. Release the pump set by removing the screws and/or cutting the straps, if fitted.
4. Check the pump set and its accessories for integrity and to make sure that there are no missing components.
5. In case of damage or missing components, contact Xylem or the Authorised Distributor.

Contents of the packaging

- Pump set
- Anti-vibration joints
- Accessories
- Pump set Installation, Use and Maintenance Manual
- Control panel wiring diagram
- Instruction manuals:
 - Of the drive display
 - Of the electric pumps
 - Of the accessories.

2.2 Guidelines for transport

Precautions



WARNING: Crushing hazard

The pump set and its components are heavy: crushing hazard.



WARNING:

Always wear personal protective equipment.



WARNING: Cutting hazard

Unpainted unit parts can be sharp or pointed: risk of injury.



WARNING:

Check the gross weight marked on the packaging.



WARNING:

Handle the pump set components in compliance with the current regulations on "manual load handling", to avoid undesirable ergonomic conditions causing risks of back-spine injury.



WARNING:

Take appropriate measures during transport, installation and storage to prevent contamination from external substances.

2.2.1 Handling with forklift



WARNING: Crushing hazard

Only use the lifting and handling points provided by the manufacturer: crushing hazard due to broken packaging or tipping of the pump set.

The figure shows the two types of packaging that can be handled with the forklift and the lifting points. Other types of packaging must be handled with a crane: see the crane lifting instructions.

Note: The packaging of special sets may differ from that shown in the figure.

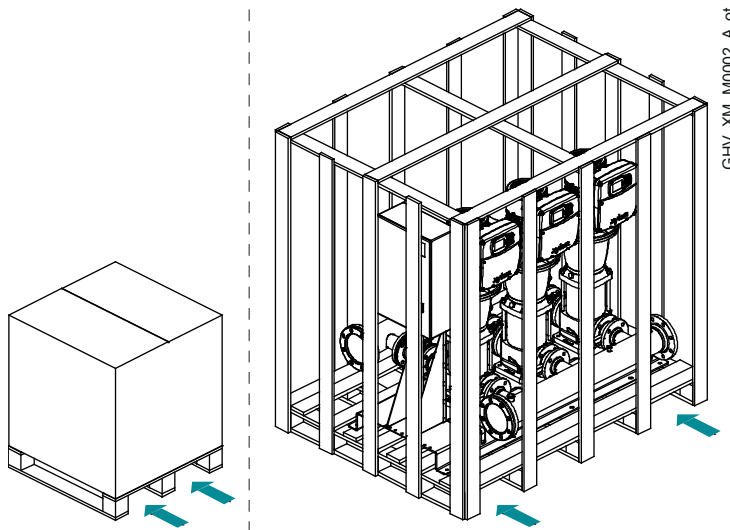

2.2.2 Lifting with a crane

**WARNING:**

Only use the lifting points contemplated by the Manufacturer.

**WARNING:**

Use ropes, chains and/or slings (hereinafter referred to as "ropes"), hooks and/or clasps (hereinafter referred to as "hooks"), shackles or eyebolts that comply with the applicable directives and are suitable for use.

NOTE:

Make sure that the harnessing does not hit and/or damage the pump set.

**WARNING:**

Lift and handle the pump set slowly to avoid stability issues.

**WARNING:**

During handling, make sure to avoid injury to people and animals, and/or damage to property.

**WARNING:**

Do not use eyebolts screwed on the motor for lifting the pump set.

Preparing the pump set for lifting

1. Remove packing materials from the product.
2. Release the pump set from the pallet by removing the screws and/or cutting the straps.
3. Fasten the ropes to the eyebolts or eyelets, depending on the model.
4. Fix the sling bar to the crane.
5. Fix the ropes to the sling bar.
6. Attach additional safety ropes, slightly slack, to the eyebolts of the motors and the sling bar.
7. Lift the sling bar and tension the ropes without lifting the pump set, checking that the ropes attached to the motors are loose.

The figures show how to lift the different models.

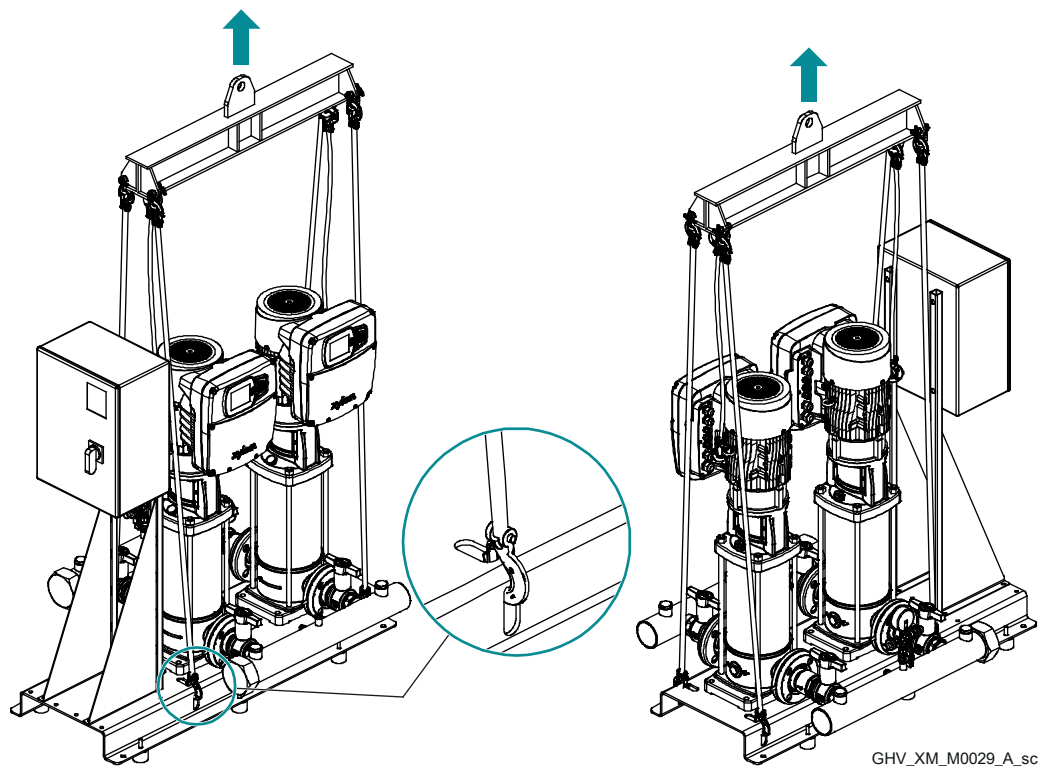
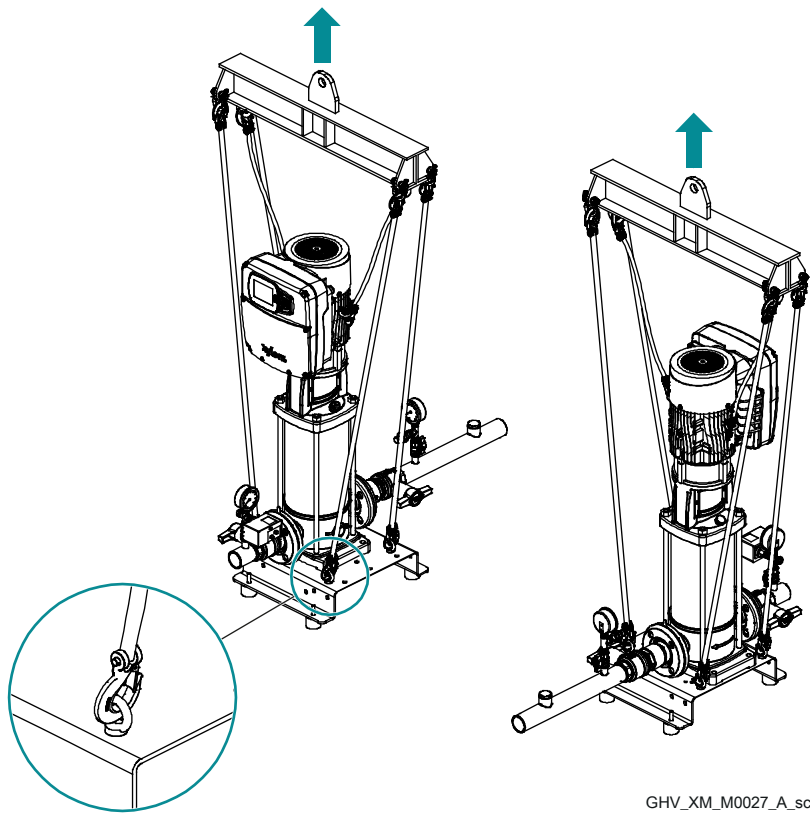

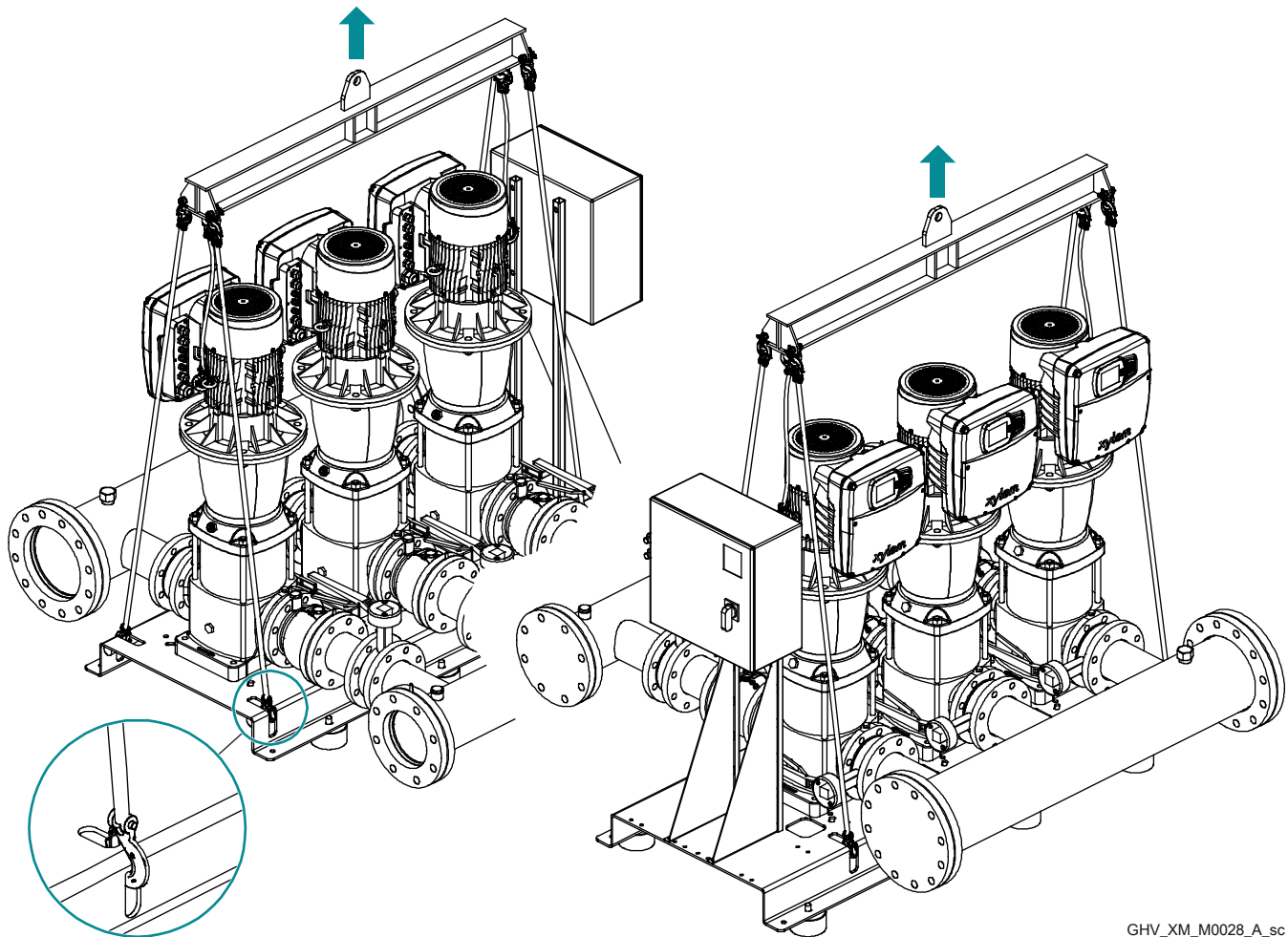

GHV_XM_M0028_A_sc

Lifting and positioning the pump set

1. Slowly lift and move the pump set.
2. Install the anti-vibration joints.
3. Put the pump set down slowly.
4. Release the ropes from the eyebolts/eyelets.
5. Remove the eyebolts.

Lifting and positioning the cabinet-type control panel

1. Remove packing materials from the product.
2. Separate the control panel from the pallet by cutting the straps.
3. Attach the ropes to the eyebolts/eyelets.
4. Fix the ropes to the crane.
5. Slowly lift and move the control panel.
6. Slowly place the control panel on the ground.
7. Release the ropes from the eyebolts/eyelets.

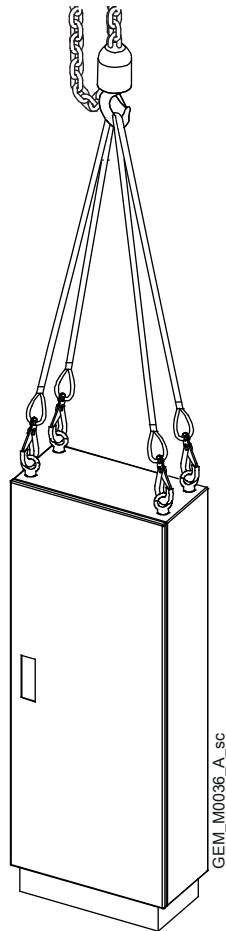

2.3 Storage

NOTE:

Keep the pump set away from sparks and naked flames.

NOTE:

Do not place objects on the pump set.

NOTE:

Protect the pump set from collisions.

Storage location

Store the pump set:

- In a covered and dry place
- Away from heat sources
- Protected from dirt
- Protected from vibrations
- At an ambient temperature between 5°C and +40°C (41°F and 104°F), and relative humidity between 5% and 95%.

Long-term storage

Empty the electric pumps by unscrewing the drain plug; this operation is essential in environments with cold temperatures. Any residual liquid in the electric pumps does not compromise the integrity and the functional characteristics.

The figure shows the positions of the drain plugs of the different electric pump models.

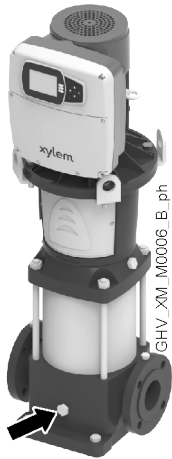

For more information on long-term storage contact the Xylem sales company or Authorised Distributor.

3 Product Description

3.1 Features

The product is a pump set consisting of one or more variable speed non-self priming electric pumps connected in parallel.

Intended use

- Pressure boosting and water supply systems
- Washing and cleaning sector, including washing of vehicles
- Circulation of hot and cold liquids, for example water or water & glycol, for heating, cooling and air conditioning systems
- Water treatment applications
- Irrigation.

Observe the operating limits in Specifications on page 51.

For other applications, contact Xylem or the Authorised Distributor.



DANGER: Potentially explosive atmosphere hazard

It is prohibited to start the pump set in environments with potentially explosive atmospheres or with combustible dusts.

Pumped liquids

Water:

- Clean
- Free of solid, abrasive or fibrous substances
- Chemically non-aggressive
- Cold.

Contact Xylem or the Authorised Distributor for other liquids.



DANGER:

It is prohibited to use this pump set to pump flammable and/or explosive liquids.

3.1.1 Use in water distribution networks for human consumption

If the pump set is intended for water supply to people and/or animals:



WARNING:

It is prohibited to pump drinking water after use with other fluids.



WARNING:

Take appropriate measures during transport, installation and storage to prevent contamination from external substances.



WARNING:

Remove the pump set from its packaging just before installation to prevent contamination from external substances.



WARNING:

After installation, run the pump set for a few minutes with several users open in order to wash the inside of the system.

3.1.2 Part names

Designation of pump set parts in standard configuration. Special configurations may not include some parts, or include different parts.

Contact Xylem or the Authorised Distributor for further information.

Pump set with single electric pump

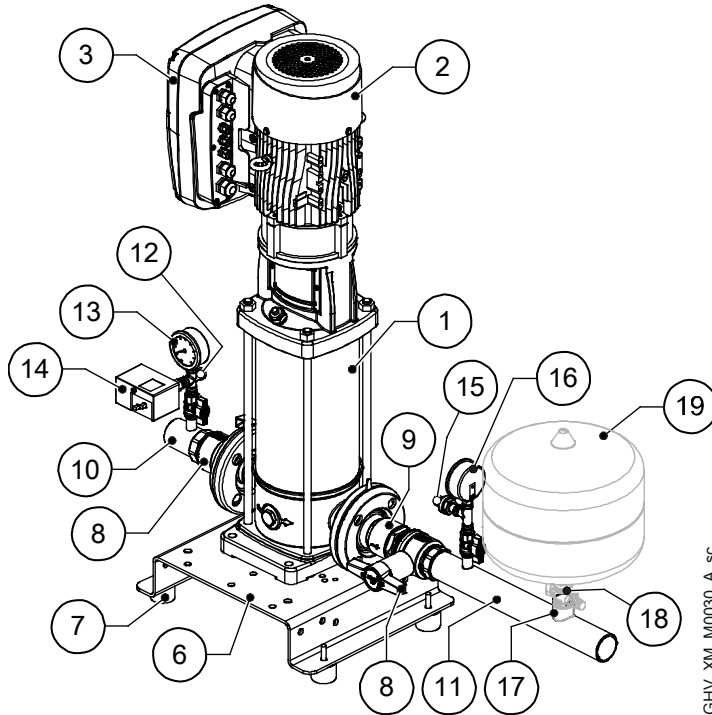

Minimum pressure control device

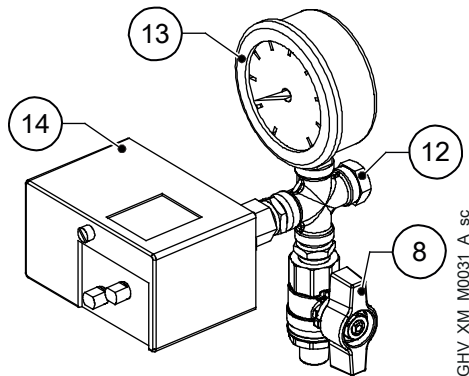

Maximum pressure control device

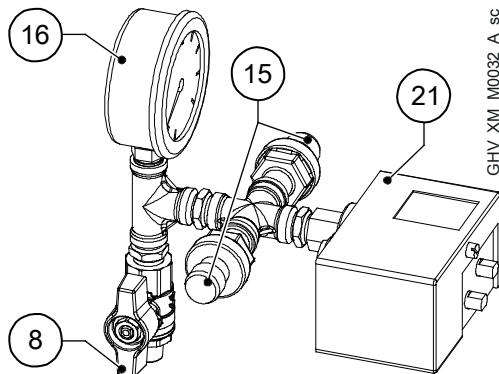

Multi-pump pump sets

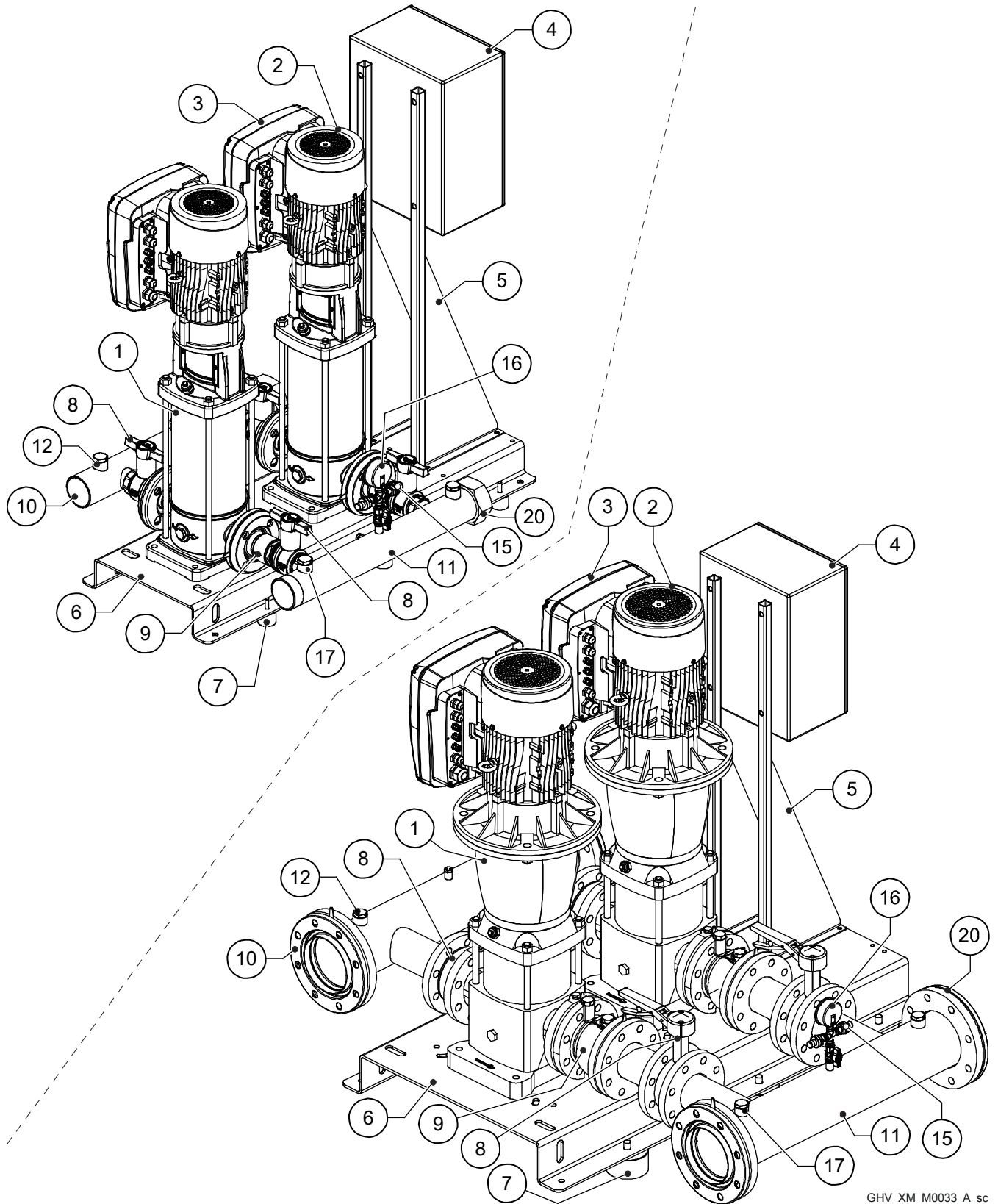

GHV_XM_M0033_A_sc

Control panel

The figure shows a standard control panel: for special control panels, please refer to the circuit diagram.

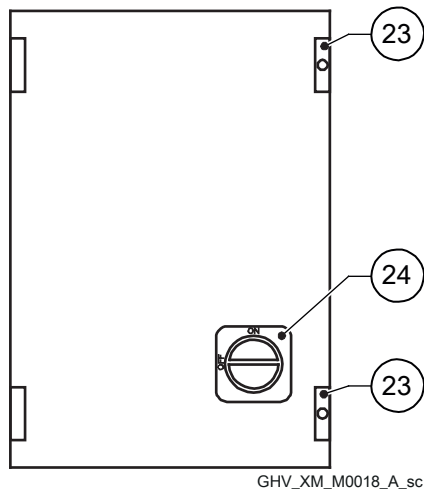

Drive

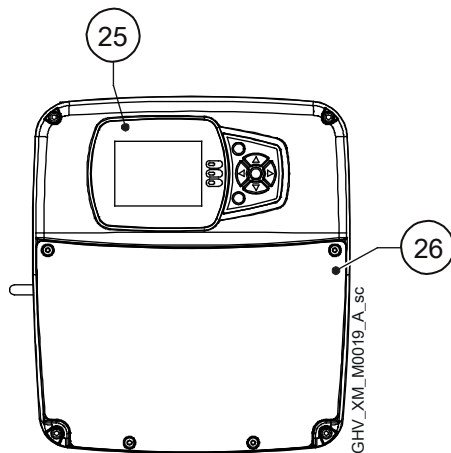

List of components

1. Pump
2. Motor
3. Drive
4. Control panel
5. Control panel bracket
6. Base
7. Anti-vibration joints
8. On-off valve
9. Check valve
10. Suction manifold
11. Delivery manifold
12. Priming hydraulic connection
13. Vacuum pressure gauge
14. Minimum pressure switch
15. Pressure sensor
16. Pressure gauge
17. Hydraulic connection of the expansion vessel
18. On-off valve or expansion vessel connection (optional)
19. Expansion vessel (optional)
20. Additional hydraulic connection for the expansion vessel
21. Maximum pressure switch
22. Additional hydraulic connection
23. Lock with key
24. Padlockable main electric switch
25. Drive display
26. Drive cover

3.2 Data plates

Pump set data plate

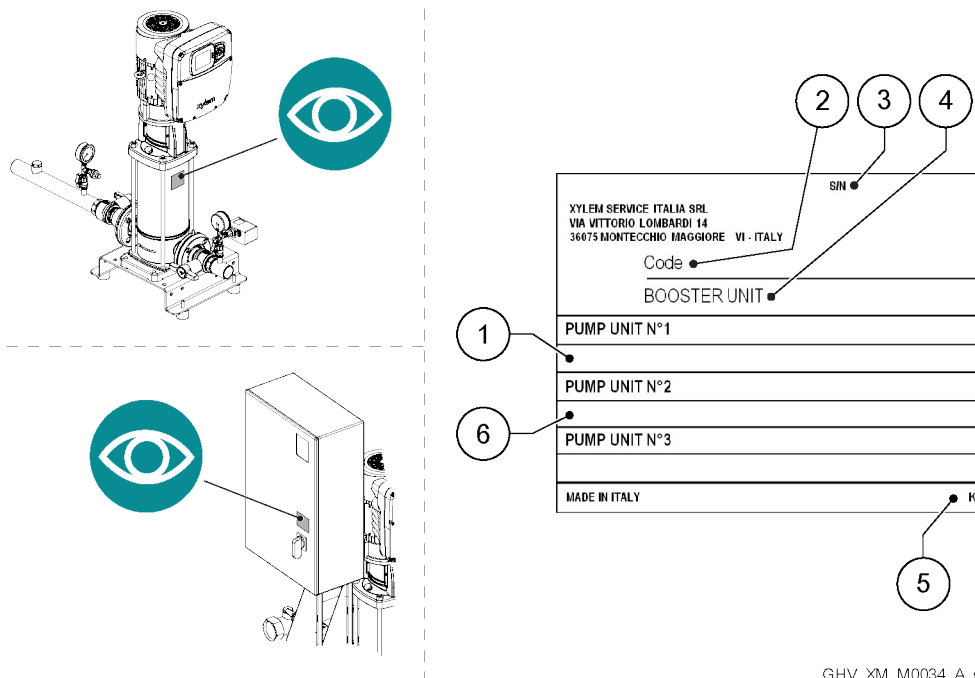

GHV_XM_M0034_A_sc

1. Main electric pump model
2. Identification code
3. Serial number + date of manufacture
4. Pump set model
5. Weight
6. Jockey electric pump model, if present

Control panel data plate

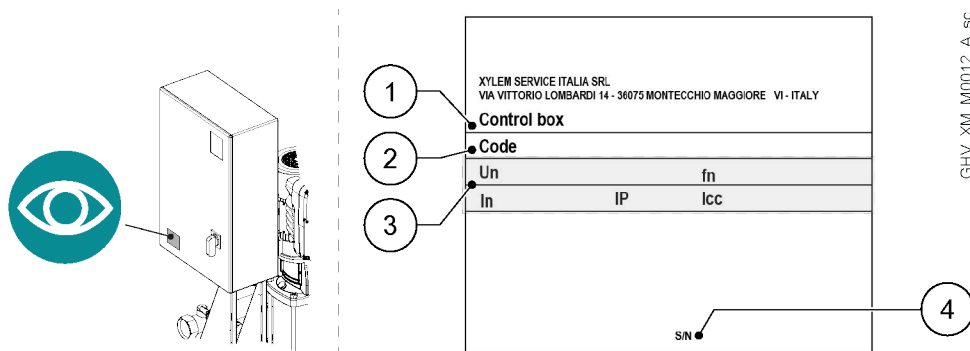

GHV_XM_M0012_A_sc

1. Control panel series
2. Identification code
3. Specifications
4. Serial number + date of manufacture

Data plates of the main electric pump and the jockey electric pump

See the relevant instruction manuals.

3.3 Identification code

Identification code for pump sets in standard configuration. Special configurations may have different codes: contact Xylem or the Authorised Distributor for further information.

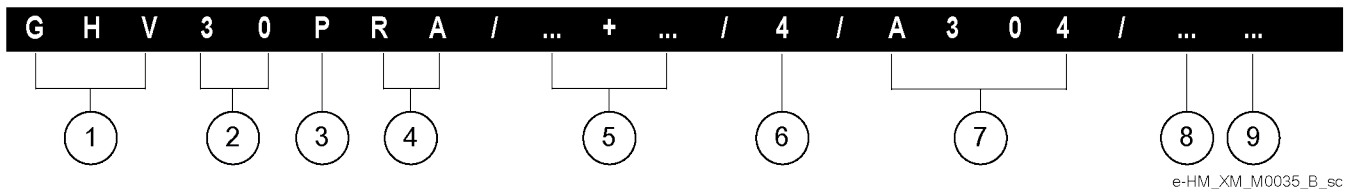

1. Series name
2. Pump set with 1 [10], 2 [20], 3 [30], 4 [40], 5 [50], 6 [60], 7 [70] o 8 [80] electric pumps
3. Equal electric pumps [] or presence of the jockey electric pump [P]
4. Non-return valve on the discharge [] or suction [RA] side
5. Model of the electric pumps present
6. Power supply voltage 3x400 Vac [4] or 3x230 Vac [3]
7. Materials, see the technical catalogue
8. Other information, see the technical catalogue
9. Customised set [PC] or other []

4 Installation

4.1 Precautions

General precautions

Before starting, make sure that the safety instructions shown in **Introduction and Safety** on page 5 have been fully read and understood.



DANGER:

All the hydraulic and electrical connections must be completed by a technician possessing the technical-professional requirements outlined in the current regulations.



WARNING:

Always wear personal protective equipment.



WARNING: Cutting hazard

Unpainted unit parts can be sharp or pointed: risk of injury.



WARNING:

Always use suitable working tools.



ATTENTION:

Handle the pump set components in compliance with the current regulations on "manual load handling", to avoid undesirable ergonomic conditions causing risks of back-spine injury.



WARNING:

When selecting the place of installation and connecting the unit to the hydraulic and electric power supplies, strictly comply with current regulations.

When connecting the pump set to a public or private aqueduct, or to a well for the supply of water for human and/or animal consumption, see Use in water distribution networks for human consumption on page 16.



WARNING:

Piping must be sized to ensure safety at the maximum operating pressure.



WARNING:

Install appropriate gaskets between the pump set and the piping system.

Electrical measures
**DANGER: Electrical hazard**

Before starting work, check that the electric power supply is disconnected and locked out, to avoid unintentional restart of the pump set, the control panel and the auxiliary control circuit.

**WARNING: Injuries hazard**

The pump set may start suddenly, even if there is no voltage at the control panel: risk of personal injury.

**WARNING:**

The electric power supply line must:

- Comply with the requirements of the applicable local directives
 - Meet the technical characteristics of paragraph **Electrical specifications** on page 52.
 - Be equipped with a suitable grounding system.
-

**WARNING:**

All the electric material used for the connection must:

- Be suitable for use
 - Be CE marked, if subject to the 2014/35/EU LOW VOLTAGE DIRECTIVE
 - Comply with the requirements of the applicable local directives.
-

**WARNING:**

Power the control panel with a dedicated line.

Earth**DANGER: Electrical hazard**

Always connect the external protection conductor (ground) to the ground terminal.

- Of the control panel, for multi-pump pump sets, or
 - Of the drive, for pump sets with single electric pump
- before completing the electrical connections.
-

**DANGER: Electrical hazard**

Connect all the electric accessories of the pump set to the ground.

**DANGER: Electrical hazard**

Check that the external protection conductor (earth) is longer than the phase conductors. In case of accidental disconnection of the pump set from the phase conductors, the protection conductor must be the last one to detach from the terminal.

**DANGER: Electrical hazard**

Install suitable systems for protection against indirect contact, in order to prevent lethal electric shocks.

4.2 Mechanical installation

1. Install the pump set on a concrete or metal foundation base sufficiently strong to ensure permanent and rigid support.
2. Check that the surface is horizontal and flat.
3. Check that the anti-vibration joints have been installed at the base.

The figures show the number and position of the anti-vibration joints in the main models. Contact Xylem or the Authorised Distributor for the replacement

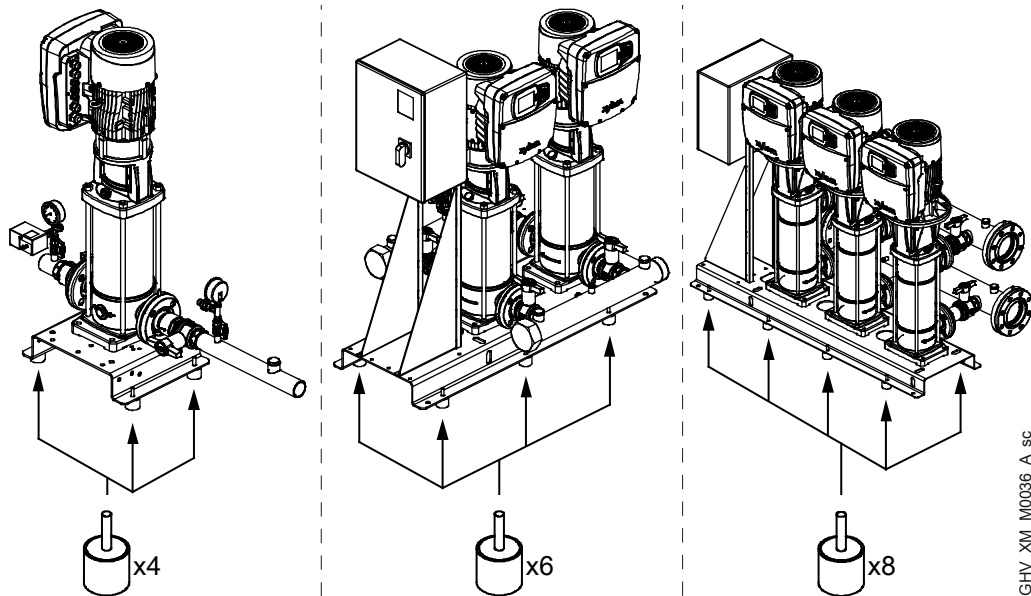

Installation area

1. Follow the provisions in **Operating environment** on page 51.
2. Place the pump set elevated above the floor.
3. Make sure that any leaks will not cause flooding to the installation area or submerge the pump set.
4. Install any tanks on the pump set or on the floor.
5. In case of outdoor installation, protect the unit from direct sunlight, rain and snow.

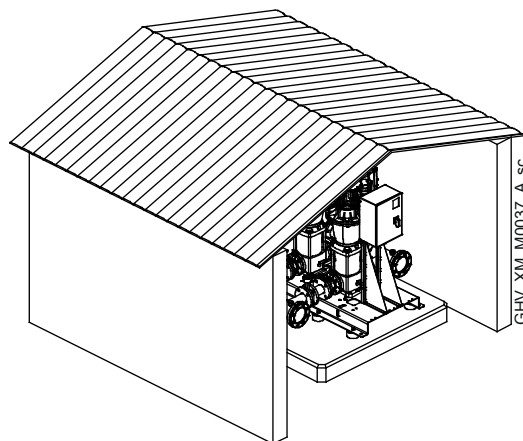

6. In case of indoor installation, the installation room must have:
 - Suitably dimensioned access to allow moving the pump set inside without disassembling it
 - A clearance area of at least 80 cm (30 in) on all sides of the pump set for ventilation, operation and maintenance purposes
 - Ventilation system with grilles and/or forced draught fans
 - Automatic emptying system in the event of flooding or spills from the pump set or pipes.

The figure shows an example of installation inside a room.

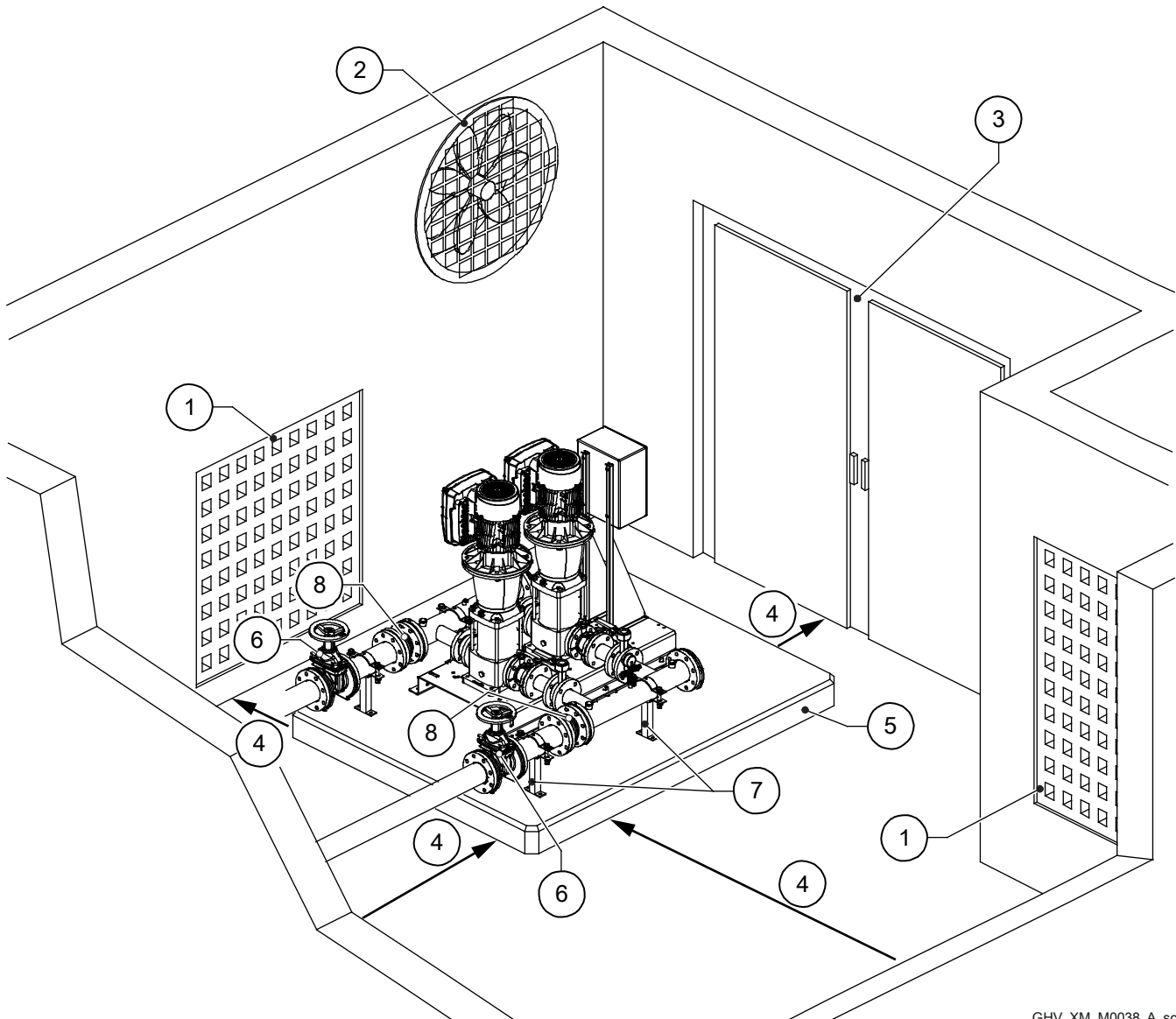

GHV_XM_M0038_A_sc

1. Air vent
2. Forced ventilation
3. Access to the room
4. Ventilation, use and maintenance clearance area
5. Elevation
6. On-off valves of the system of the user
7. Piping system support
8. Anti-vibration joints

Requirements on the concrete foundation

- The concrete must have a compression resistance of C12/15 and meet the requirements of exposure class XC1 according to EN 206-1
- Sizes must be appropriate for the sizes of the base or pump set support plate
- The foundation weight must be ≥ 1.5 times the weight of the pump set filled with liquid (≥ 5 times the weight of the pump set if quieter operation is required)

Pump set positioning

1. Place the set, which may consist of several units, on the floor.
2. Using a spirit level, make sure that the pump set is level.
3. Remove the guards protecting the manifolds, if fitted.
4. In case of several units, connect them through the manifolds.

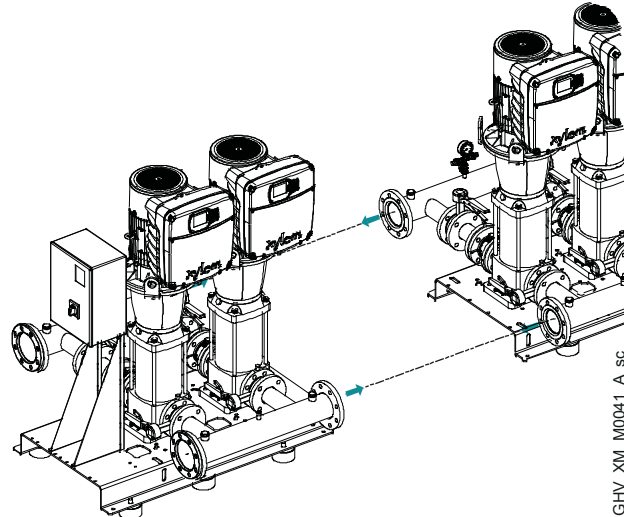

5. Align the suction and discharge ports to their piping.

Reducing vibrations

The motor and the flow of liquids in the system can generate vibrations, amplified from the possible incorrect installation of the pump set and the piping. See **Hydraulic connection**.

4.3 Hydraulic connection

Refer to the hydraulic diagrams shown in the figures below.

Note: the diagrams are representative for pump sets in standard configuration. Special configurations may have different diagrams and parts: contact Xylem or the Authorised Distributor for further information.

1. Do not install the pump set at the lowest point of the system, to avoid the accumulation of sediments.
2. Install an automatic relief valve at the highest point of the system to eliminate air bubbles.
3. Remove any welding residues, deposits and impurities in the pipes that could damage the pump set; install a filter if necessary.
4. Support the pipes independently to prevent them from weighing on the manifolds.
5. Install the complete piping system.
6. To reduce the transmission of vibrations from the unit to the system and vice versa, install anti-vibration joints on the suction and discharge manifolds.

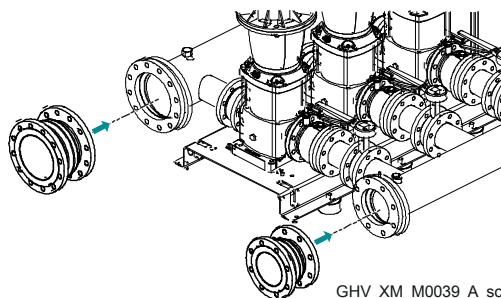

7. Fit the measuring devices, if provided (flow meter, temperature sensor, etc.).
8. In order to reduce flow resistance, the pipe on the suction side must be:
 - As short and as straight as possible

- For the section connected to the pump set, straight and without bottlenecks, for a section equal to at least six times the diameter of the piping
 - Wider than the suction port; if necessary, install an eccentric reducer with horizontal top surface
 - Without bends: if this cannot be avoided, with a radius as wide as possible
 - Without traps and 'goosenecks'
 - With valves with a low specific flow resistance.
9. Make sure that air cannot enter the piping system through the suction vortex: if necessary, install a vortex protection device.
 10. Install the expansion vessel, making sure that the nominal pressure is higher than the maximum pressure that can be reached by the system.
 11. To exclude the pump set from the system for the purpose of maintenance, install an on-off valve on the suction side and another one on the discharge side.
 12. Install a dry-run protection device on the suction side: minimum pressure switch, float switch or electrode probes.
 13. Sufficiently submerge the end of the suction pipe in the liquid, in order to prevent any air from penetrating through the suction vortex when the level is at the minimum.
 14. In case of suction lift installation, the suction pipe must have an increasing slope towards the pump set exceeding 2%, to avoid air pockets. Also install:
 - A foot check valve that guarantees full opening (full section)
 - A filling on-off valve to facilitate the removal of the air and priming.

Diagrams of positive suction head systems, single and multiple electric pump sets

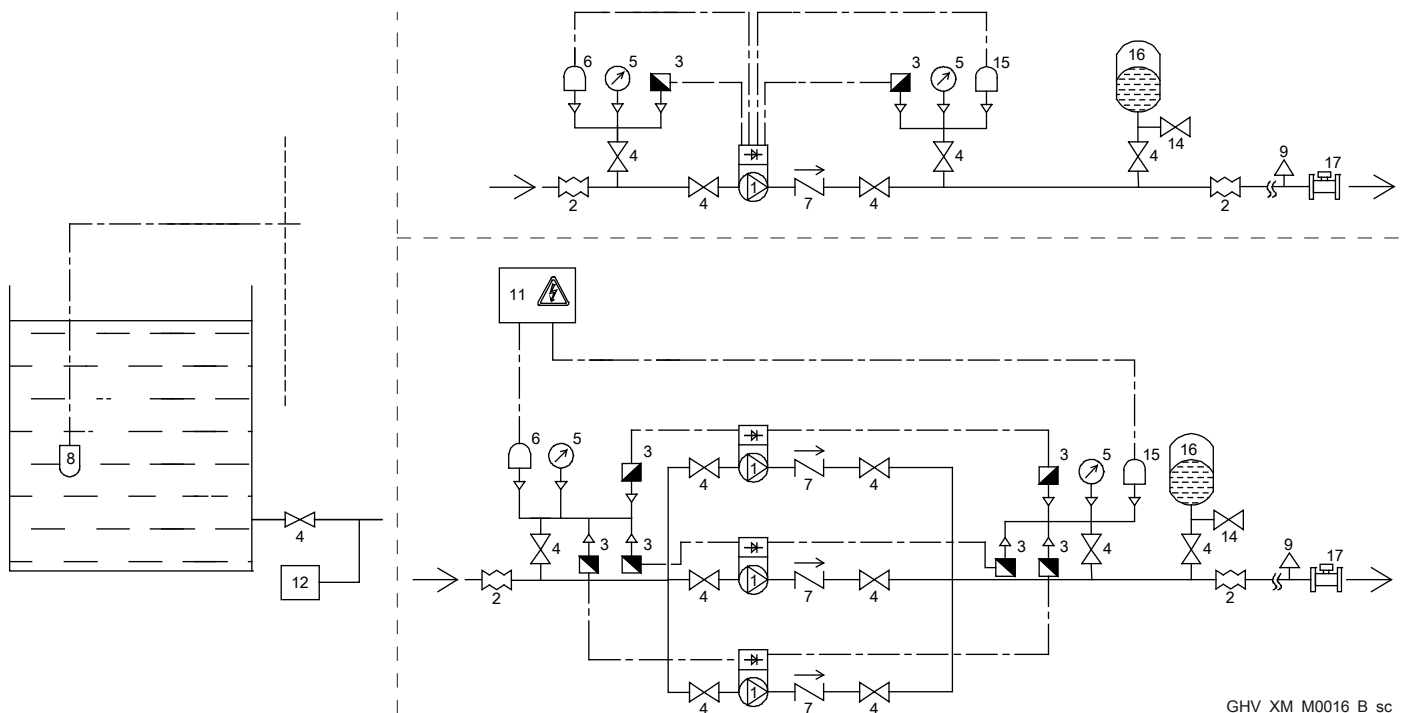

GHV_XM_M0016_B_sc

Diagrams of suction lift systems, single and multiple electric pump sets

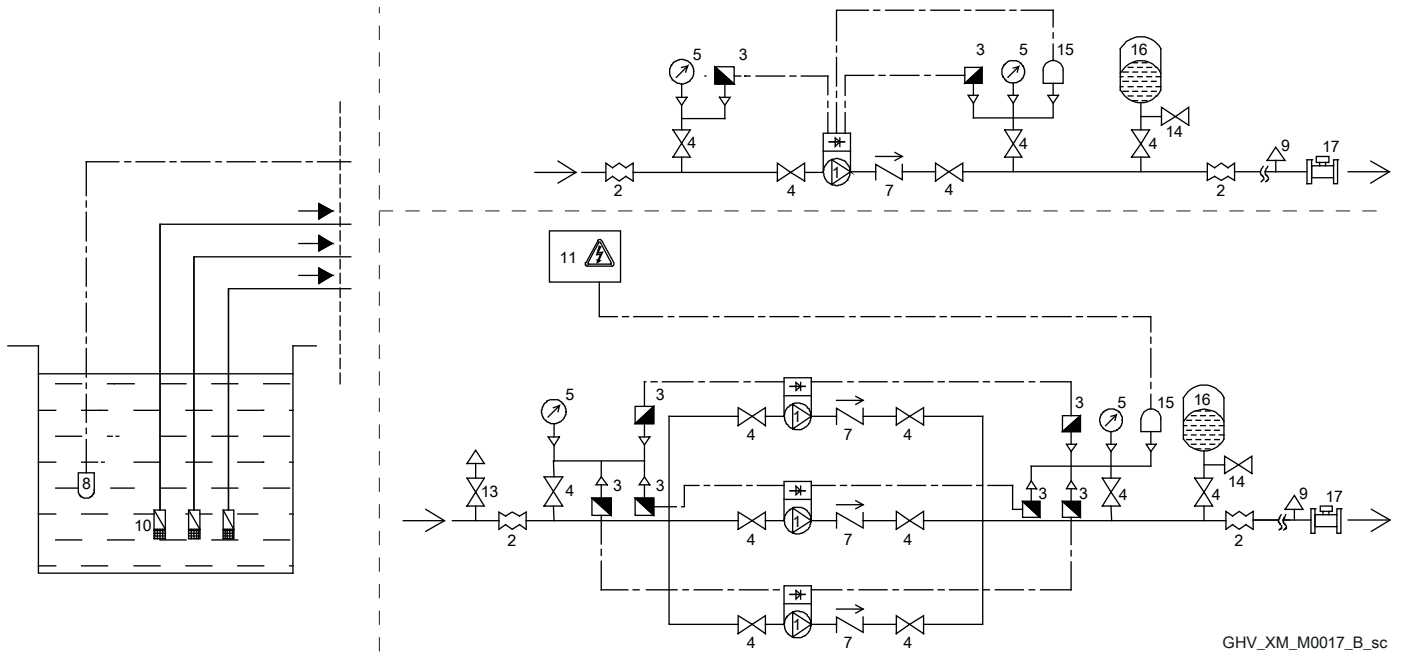

GHV_XM_M0017_B_sc

List of components

1. Electric pump with drive
2. Anti-vibration joint
3. Pressure sensor
4. On-off valve
5. Pressure gauge or vacuum pressure gauge
6. Minimum pressure switch
7. Check valve
8. Electrode probes or float
9. Bleed valve
10. Foot check valve with filter
11. Control panel
12. Pressurised circuit
13. Filling on-off valve
14. Drain tap
15. Maximum pressure switch
16. Expansion vessel
17. Flow meter

4.3.1 Protection against dry running

In the control panel are terminals for connecting a minimum pressure switch, a float switch or electrode probes (and corresponding level relay module, available as optional): please refer to the circuit diagram.

When the minimum pressure or level conditions are restored, the electric pumps start automatically.

Note: A pre-calibrated pressure switch is installed on the suction manifold of GHV../PMA pump sets.

The image shows two standard pressure switches.

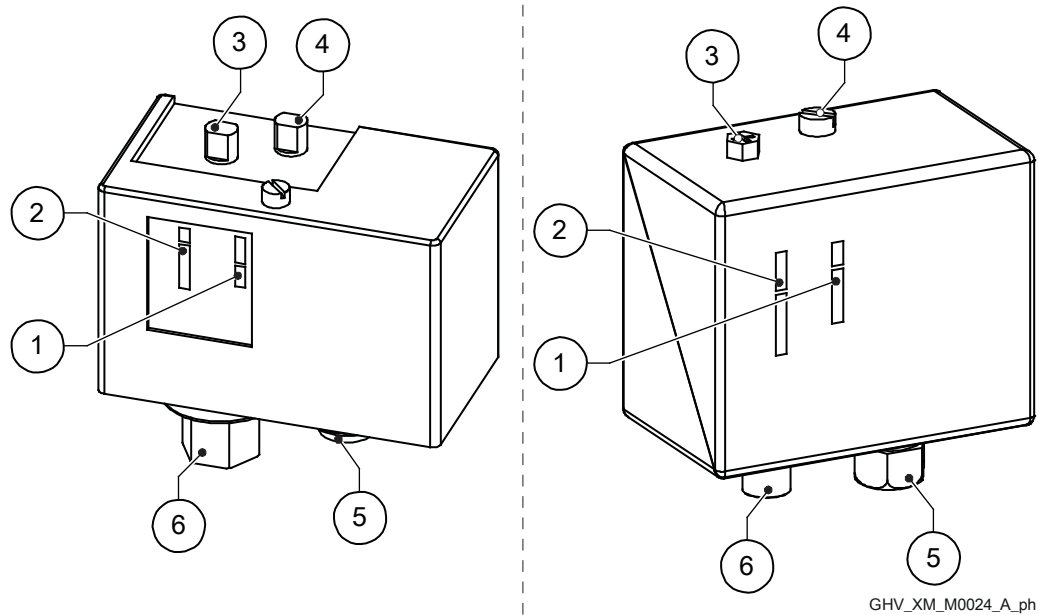

1. Pressure differential value indicator
2. Electric contact control pressure value indicator
3. Electric contact control pressure value regulator
4. Pressure differential value regulator
5. Cable Gland
6. Pipe connection

4.4 Guidelines for electrical connection

1. Check that the electrical leads are protected against:
 - High temperature
 - Vibrations
 - Collisions
 - Liquids.
2. Check that the power supply line is provided with:
 - A short circuit and overload protection device of appropriate size
 - A mains disconnection device with contact opening distance ensuring complete disconnection for overvoltage III category conditions.
3. Size the power supply line and the protections consistently with the data on the data plate and the electric diagram of the control panel.
4. To connect pump sets without control panel, please refer to the electric pump manual.

NOTE:

- Keep ON/OFF control, electric pump running relay and electric pump fault relay cables at least 200 mm (8 in) away from the power supply cable
- Do not intersect the power supply cables; if this cannot be avoided, a 90° intersection angle is permitted.

Cable requirements

Pump sets with control panel are supplied with the power supply cables for the electric pumps and the control cables, while pump sets without control panels are supplied without. When replacing the supplied cables or installing new ones, please refer to the electric pump manual.

The cables must be:

- Compliant with the requirements of the applicable local guidelines concerning cross-sectional area and ambient temperature
- With a minimum heat resistance of 70°C (158°F).

In addition:

- Cables must never get in contact with the motor and the piping.
- The wires connected to the power supply terminals and to the electric pump running and fault signal relays must be separated from the others by means of reinforced insulation.

4.5 Guidelines for the control panel

NOTE:

The control panel must match the ratings on the unit data plate.

1. Refer to the wiring diagram.
 2. In case of several units, connect all electric pumps to the control panel.
 3. Connect the protective conductor (ground) to the control panel.
 4. Connect the power conductors to the control panel.
 5. Connect, if required:
 - A minimum pressure switch, or
 - A float switch, or
 - Electrode probes.
 6. If necessary, connect the dry contacts of the relays for the following notifications:
 - Electric pump running
 - Electric pump failure.
 7. Connect, if required:
 - The flow meter
 - The liquid temperature sensor.
- See the control panel wiring diagram.

Fuses and/or automatic switches

- An electronically activated drive function ensures motor overload protection. The overload protection function calculates the increment level in order to activate the timing of the trigger function (motor stop).
The higher the input current, the faster the response. The function provides Class 20 protection for the motor.
- The drive must be equipped with overcurrent and short-circuit protection to prevent the overheating of the power supply cables. Line fuses or automatic switches must be installed to ensure this protection. Fuses and automatic switches must be provided by the installer as part of the installation.
- Use the recommended fuses and/or automatic switches on the power supply side as protection in the event of drive component failure (first failure). The use of the recommended fuses and automatic switches ensures that possible damage to the drive is limited to the inside of the same. For other types of protection, ensure that the passing energy is equal to or less than that of the recommended models.
- Compliance with UL requirements is only ensured by using approved fuses of category JDDZ.2/8 type T and with the characteristics indicated below and in the table.
- The fuses shown in the table are suitable for use on a circuit capable of releasing 5000 Arms (symmetrical), maximum 480 V. With the indicated fuses, the short-circuit current rating (SCCR) for the drive is 5000 Arms.

The figure shows the recommended fuses and switches.

Model	Xylem motor model	Three-phase power supply voltage, Vac	Non-UL fuses, type gG, A	UL fuses, type T, manufacturer and model				MCB S203 model ABB Switches
				Bussmann	Edison	Littelfuse	Ferraz-Shawmut	
B	EXM.../3...B..	200 - 240	16	JJN-15	TJN (15)	JLLN 15	A3T15	C16
C	EXM.../3...C..		30	JJN-30	TJN (30)	JLLN 30	A3T30	C32
D	EXM.../3...D..		63	JJN-60	TJN (60)	JLLN 60	A3T60	C63
B	EXM.../4...B..	380 - 480	16	JJS-15	TJS (15)	JLLS 15	A6T15	C16
C	EXM.../4...C..		30	JJS-30	TJS (30)	JLLS 30	A6T30	C32
D	EXM.../4...D..		63	JJS-60	TJS (60)	JLLS 60	A6T60	C63

NOTE:

Refer to the current shown on the data plate for the selection of the protective device and comply with local and national regulations for its sizing.

4.5.1 Ground fault circuit interrupter, GFCI

If a switch is installed to protect people against earth leakage, check that:

- It is suitably sized for the system configuration and environment of use
- It has a starting delay to prevent faults caused by transient earth currents
- It can detect alternate or direct current, it is marked with the symbols shown in the figure.

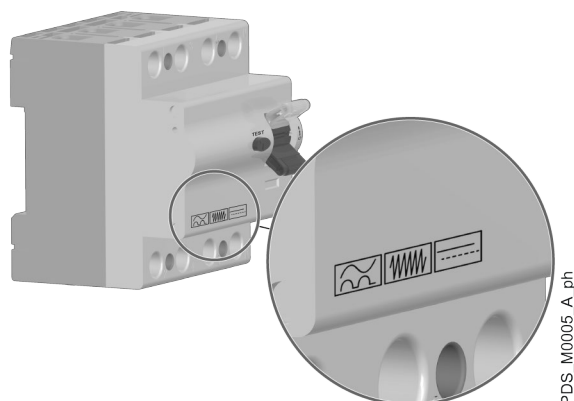

NOTE:

When using an automatic earth leakage switch or an earth fault switch, make sure to consider the total earth leakage current of all the electric devices of the system.

4.6 Guidelines for the drive: GHV10

Guidelines for the drive of a pump set with single electric pump, model GHV10.

4.6.1 Positioning

1. Remove the bolts that secure the motor to the pump.
2. Rotate the motor in the desired position without removing the couplings.
3. Reposition and tighten the bolts at the torque indicated in the table.

Flange size, MEC	Bolt size	Torque, Nm (lbf-in)
71, 80	M6	6 (53)
90, 100, 112	M8	15 (133)
132	M12	50 (443)
160, 180, 200, 225, 250	M16	75 (664)

4.6.2 Power supply connection

NOTE:

The cable cross section must be sized according to the rated current of the unit. Observe local and national regulations for cable sizing.

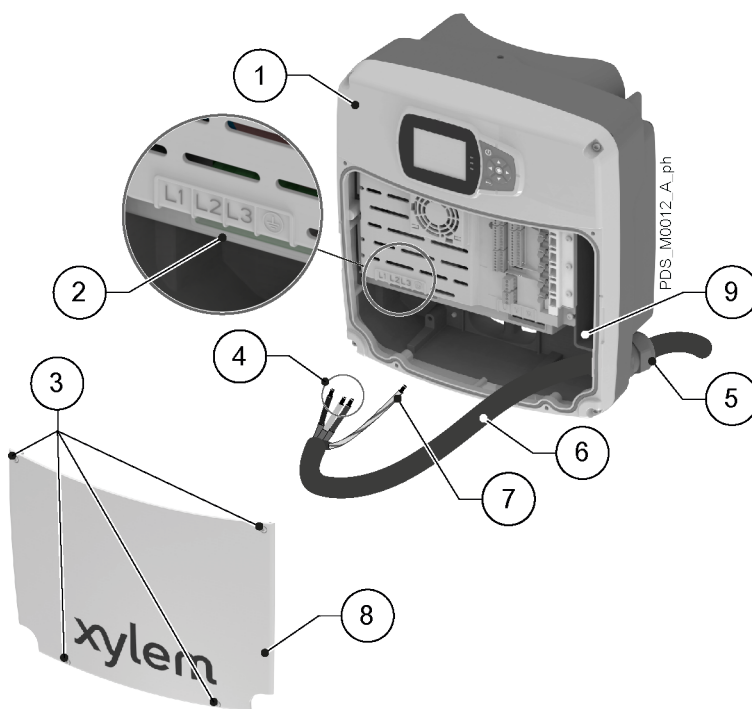

1. Drive
2. Terminals
3. Screws of the cover
4. Phase conductors
5. Cable Gland
6. Power supply cord
7. Protection conductor (earth)
8. Cover
9. Additional earth connection

1. Remove the cover and observe the wiring diagrams inside.
2. Insert the power cable in the power supply cable gland:

Model size	Type of cable gland	Cable gland torque, Nm (lbf·in)
B	M20	6 (53)
C	M25	7 (71)
D	M40	12 (106)

3. Tightly connect the conductors, making sure that the protection one is longer than the phase ones. In models size:
 - B and C, open the springs with a slotted screwdriver with a maximum width of 2.5 mm (0.98 in)
 - D, tighten the terminal screws with a Pozidriv screwdriver and tightening torque of 4 Nm (35 lbf·in).

Note: For size D models, it is advisable to use cable terminals with a plastic sheath.

4. Tighten the cable gland.
Torque: see the table in point 2.
5. Fit the cover and tighten the screws.
Tightening torque: 3 Nm (27 lbf·in) ± 15%.

Cable input characteristics

Type of cable gland	Cable diameter, mm (in)	Tightening torque on the support plate, Nm (lbf·in)	Cable gland torque, Nm (lbf·in)	Number of inputs according to model size		
				B	C	D
M12	3-6.5 (0.1-0.26)	2.7 (24)	1.5 (13)	3	3	-
M16	5-10 (0.2-0.4)	5 (44)	3 (27)	3	3	5
M20	8-13 (0.3-0.5)	7 (62)	6 (53)	1	-	3
M25	11-17 (0.4-0.7)	7.5 (66)	7 (62)	-	1	-
M40	19-28 (0.7-1.1)	14 (124)	12 (106)	-	-	1

NOTE:

During installation, check that the cable glands on the support plate are tightened correctly, according to the values in the table.

NOTE:

When replacing cable glands and/or installing adapters, use suitable approved components to maintain degrees of protection IP55 and NEMA 4.

Characteristics of power terminals and conductors

Model size	Connection type	Type and cross-section of installable conductors	Stripping length, mm (in)
B and C	Spring	<ul style="list-style-type: none"> • Rigid: 1.5-10 mm² • Flexible: 1.5-6 mm² • Cable terminals without plastic sheath: 1.5-6 mm² • Cable terminals with plastic sheath: 1.5-4 mm² • UL/CSA compliant: AWG 16-8 	15 (0.6)
D	With screw	<ul style="list-style-type: none"> • Rigid: 2.5-35 mm² • Flexible: 2.5-25 mm² • Cable terminals without plastic sheath: 2.5-25 mm² • Cable terminals with plastic sheath: 2.5-25 mm² • UL/CSA compliant: AWG 14-2 	

5 Control

Introduction



DANGER: Electrical hazard

If the drive display is damaged, contact Xylem or the Authorised Distributor.



DANGER: Risk of falling from heights

When working at heights, use appropriate personal protective equipment.



WARNING: Hot surface hazard

Only touch the drive display buttons. Pay attention to the high temperature released by the electric pump.

5.1 Description of the drive display

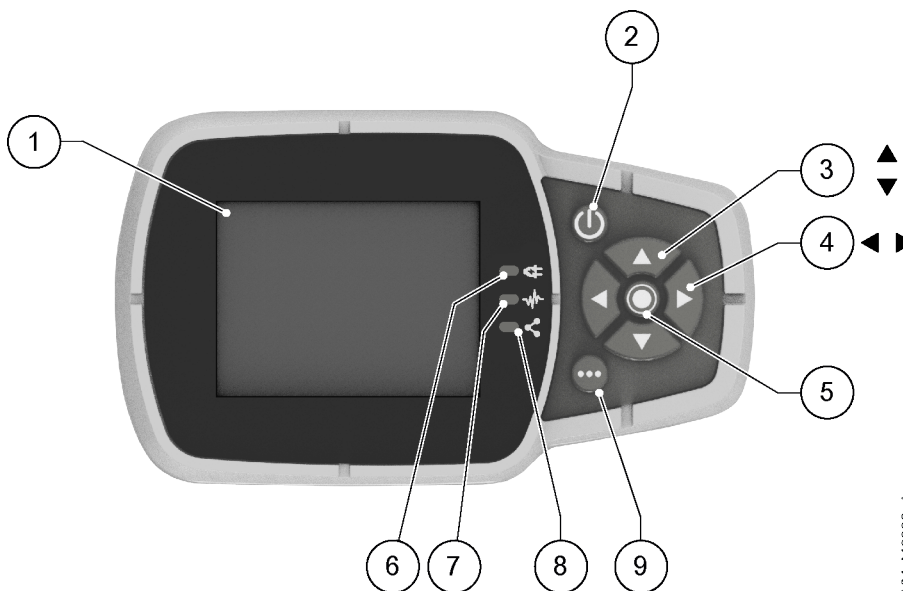



XW_M0002_A_sc

Position number	Name	Function
1	Display	
2	ON/OFF button	<ul style="list-style-type: none"> Start and stop the electric pump Reset the errors by pressing for 5 seconds.
3	UP and DOWN arrow keys	<ul style="list-style-type: none"> Move vertically between menu options Perform a manual switch-over on a multi-pump system by pressing the DOWN arrow (extended pressure) Rotate the display 180° by simultaneously pressing ENTER and the UP arrow (extended pressure).
4	RIGHT and LEFT arrow keys	<ul style="list-style-type: none"> Move horizontally to navigate home screens and menus Lock and unlock the display by simultaneously pressing the RIGHT and LEFT arrows (extended pressure).

Position number	Name	Function
5	SEND button	<ul style="list-style-type: none"> Advancing through the menu levels Confirm the selection of a parameter Confirm the value of a parameter.
6	Unit LED on	Indicate that the electric pump is powered.
7	Unit status LED	Indicate: <ul style="list-style-type: none"> Motor not powered (off) Alarm active and motor stopped (yellow) Electric pump error and motor stopped (red) Motor started (green) Alarm active and motor started (yellow alternating green).
8	Connection status LED	Indicate: <ul style="list-style-type: none"> BMS communication disabled (off) BMS communication active (green) Wireless communication with mobile device established (fixed blue) Wireless communication with mobile device being established (flashing blue) Wireless communication and BMS communication active (blue alternating green).
9	Multifunction button	<ul style="list-style-type: none"> Access the parameter menu or additional functions according to the screen on the display. Enable the unit to a mobile device (extended pressure)

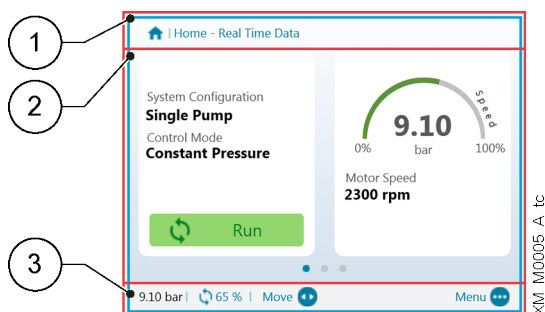
5.1.1 Graphic display



Position number	Name	Description
1	Header bar	It shows static information and messages relating to the operating conditions, such as: <ul style="list-style-type: none"> Alarms Errors Multi-pump operation.
2	Main screen	It shows the main information and allows the operating parameters to be changed. There are up to 5 screens, which can be navigated by pressing the RIGHT and LEFT arrow keys. The symbol  next to an entry indicates an editable parameter.
3	Lower bar	Show: <ul style="list-style-type: none"> On the left, the essential operating information, such as the actual adjustment value and the speed percentage at which the electric pump is operating On the right, the buttons available for interaction in the main screen.

5.1.2 Parameters menu

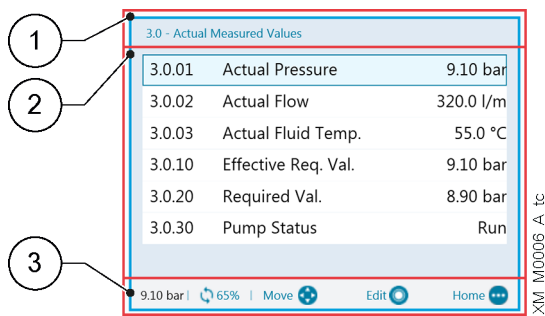

Position number	Name	Description
1	Header bar	It shows the parameter path at menu and submenu level.
2	Parameter list	Show: <ul style="list-style-type: none"> • The index, • The name, • The preview of the value of the parameters for the current menu level. To advance a level or change the value, press SEND or the RIGHT arrow key.
3	Lower bar	Show: <ul style="list-style-type: none"> • On the left, the essential operating information, such as the actual adjustment value and the speed percentage at which the electric pump is operating • On the right, the buttons available for interaction in the main screen.

The menu is split into 3 levels:

- Main
- Submenu
- Parameters.

To display or change a parameter:

1. Press the function button in the main screen.
2. Enter the password using the arrow keys.
3. Press SEND.
 Note: after 10 minutes of inactivity, the password must be re-entered.
4. Press the RIGHT arrow key or SEND to advance between levels, or the LEFT arrow key to return.

5.1.3 Electric pump start using the drive display

1. Check the connection between the START/STOP and GND inputs on the terminal board.
2. Press ON/OFF to start the electric pump.
 Note: if parameter 1.0.45 Autostart is configured to "Yes", it will not be necessary to press ON/OFF again at the next start.
3. With the electric pump in operation, the working setpoint can be changed by switching to the second screen.

5.1.4 Operating mode change

The electric pump parameters are set at the factory and the pump is ready for use. To change parameters and advanced features, access the configuration menu.

1. Press the multi-function button.
2. Enter the password using the arrow keys.
3. Press SEND.
4. Navigate through the menus to locate the parameter or function to be changed.

5.1.5 Error reset

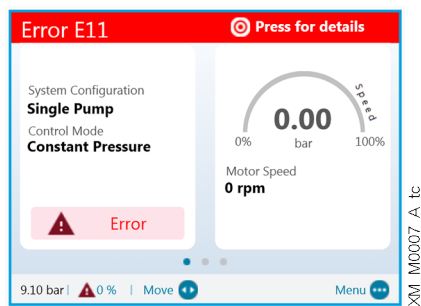

In the event of an error, the unit automatically makes several attempts to reset itself, where permitted: if the attempts are unsuccessful, the electric pump stops and the display shows the error code.

To eliminate the error:

1. Open the first main screen by pressing SEND.
2. Read the description of the error in the screen.
3. Identify the cause and follow the troubleshooting instructions
4. Reset the error by pressing and holding down ON/OFF for 3 seconds: the electric pump returns to the status before the error.

5.2 Xylem X App

Introduction

Available for mobile devices with wireless technology operating system.

Use the App to:

- Check the status of the electric pump
- Configure parameters
- Interact with the electric pump and obtain data during installation and maintenance
- Generate a work report
- Contact the assistance service.

Download the App and connect the mobile device with the electric pump

1. Download the Xylem X App to the mobile device from App Store¹ or Google Play² by scanning the QR code:



¹ Compatible with iOS® operating systems with version 11.0 and above

² Compatible with Android operating systems with version 8.0 and above

2. Complete the registration.

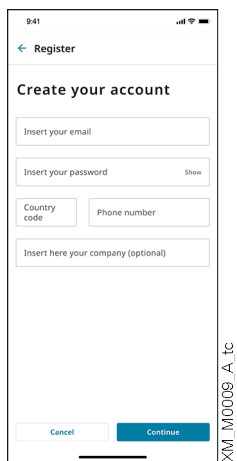

- 3. On the drive display, press the wireless communication button.
- 4. Add the electric pump to the user profile.

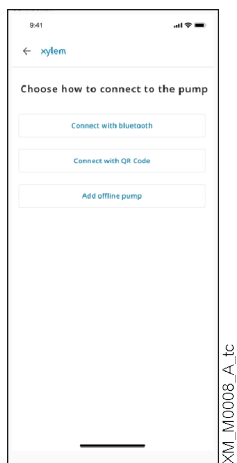

- 5. When the connection has been established, the connection light turns blue steady: it is now possible to control the electric pump using the mobile device.

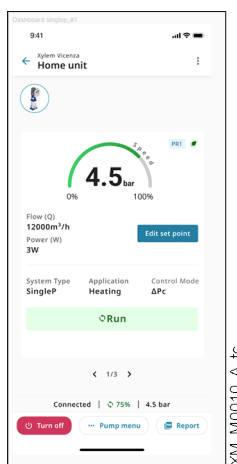

6 Use and Operation

6.1 Precautions



WARNING: Injuries hazard

Check that the protection devices of the coupling are installed, when applicable: risk of physical injury.



WARNING:

Make sure that the drained liquid cannot cause damage or injuries.



WARNING: Injuries hazard

In the case of liquids that are excessively hot or cold, pay attention to the risk of injury.



WARNING: Electrical hazard

Check that the pump set is properly connected to the mains power supply.



WARNING: Hot surface hazard

Be aware of the extreme heat generated by the pump set.



WARNING:

It is prohibited to place flammable materials near the pump set.

NOTE:

Check that the shaft can turn smoothly.

NOTE:

It is prohibited to operate the pump set when dry, not primed and below or above the flow rate range.

NOTE:

It is prohibited to operate the pump set with the on-off valves closed.

NOTE:

It is prohibited to use the pump set in the case of cavitation.

NOTE:

Bleed the pump set properly before starting it.

NOTE:

The maximum pressure delivered by the pump set at the discharge side, determined by the pressure available on the suction side, must not exceed the maximum pressure (PN).

6.2 Filling and priming

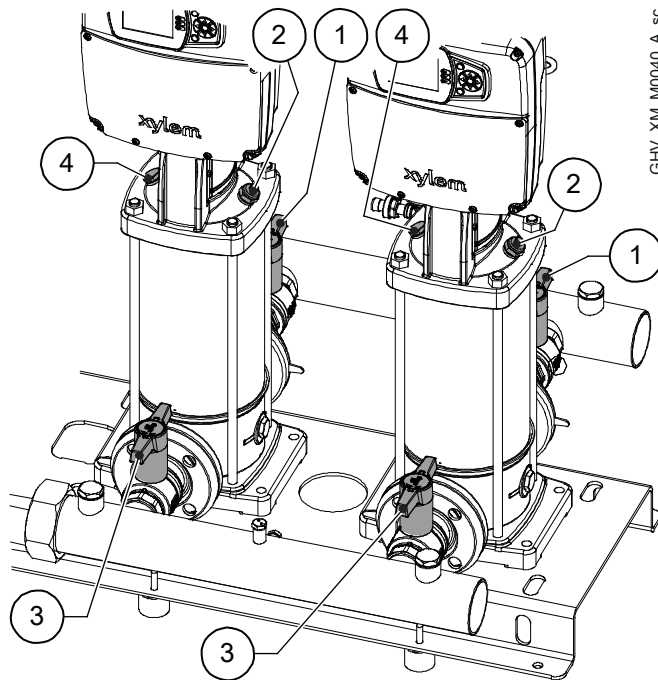

1. On-off valve on discharge line
2. Filler cap and relief valve
3. On-off valve on suction line
4. Drain plug

Positive suction head installation

1. Shut off the suction and discharge on-off valves of all the electric pumps.
2. On 3 and 5SV model electric pumps only, loosen the drain plug screw.
3. Loosen the relief valve and the filler cap.
4. Slowly open the suction valve until the liquid regularly comes out from the relief valve of the electric pump; if necessary, keep loosening it.
5. On models 3 and 5SV only, tighten the drain plug screw.
6. Tighten the relief valve.
7. Repeat steps 2 to 6 for each electric pump.
8. Slowly and fully open the on-off valve.

Suction lift installation

1. Open the suction on-off valve and shut off the discharge valve of all the electric pumps.
2. On 3 and 5SV model electric pumps only, loosen the drain plug screw.
3. Remove the filler cap.
4. Fill the electric pump.
5. On models 3 and 5SV only, tighten the drain plug screw.
6. Close the filler cap.
7. Repeat steps 2 to 6 for each electric pump.
8. Slowly fully open the valve on the discharge side.

6.3 First commissioning

NOTE:

If there is a risk of the pump set running at a flow rate below the minimum expected, install a bypass circuit.

Preliminary operations

1. Check that all the operations indicated **Filling and priming** on page 40 have been carried out correctly.
2. On the control panel, turn the main switch to OFF.
3. Open the control panel.
4. Check that all switches are on I-ON.
5. Close the control panel.
6. Turn the switch to I-ON.
7. Completely open the suction and discharge on-off valves of the pump set and, if present, the main valve of the system.

Check that the expansion vessel is pre-charged correctly.

1. Check that the pressure of the system is zero, to avoid affecting the reading of the pressure gauge.
2. Unscrew the valve cap.

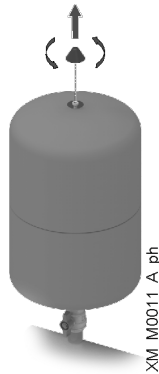

3. Apply the pressure gauge to the valve and check the pressure.
Pre-charge pressure = 90% of Pstart.

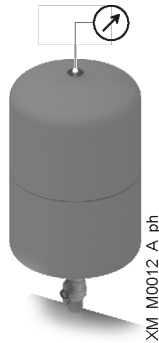

4. Remove the pressure gauge and screw the cap.

Startup

1. Shut off the discharge on-off valve of one electric pump almost completely.
2. Fully open the suction on-off valve.
3. Start the electric pump by pressing the ON/OFF button on the drive display.
4. Gradually open the discharge valve until half open.
5. Wait a few minutes and then fully open the discharge on-off valve.
6. Press ON/OFF to stop the electric pump.
7. Repeat steps 1 to 6 on all electric pumps.
8. Start all electric pumps by pressing the ON/OFF button on the drive display.

Final checks

With the pump set in operation, check that:

- No liquid is leaking from the pump set or pipes
- The maximum pressure of the pump set at the discharge, determined by the available suction pressure, is lower than the maximum pressure (PN)
- The pressure indicated in the drive display of each electric pump is the same as that of the discharge pressure gauge
- There is no unwanted noise or vibrations
- No vortices can occur at the end of the suction pipe, at the point of the foot check valve (suction lift installation)
- The devices to prevent the absence of liquid (float or probes), or the minimum pressure devices work correctly
- When the main valve is closed and the flow rate is zero, the pump set stops automatically.

NOTE:

If the pump set does not deliver the required pressure, repeat the operations in **Filling and priming**.



WARNING:

After the start, run the pump set for a few minutes with several users open in order to wash the inside of the system.

Settling of the mechanical seal

The pumped liquid lubricates the seal faces of the mechanical seal; under normal conditions, a small amount of liquid may leak out. When the electric pump is run for the first time or immediately after the seal is replaced, more liquid may leak out temporarily. To help the seal settle and to reduce leaking:

1. Close and open the on-off valve on the discharge side two or three times with the electric pump running.
2. Stop and start the electric pump two or three times.

6.4 Manual stop

Press the ON/OFF button on the drive display or open the provided enable contact (if used).

7 Maintenance

7.1 Precautions

Before starting, make sure that the safety instructions shown in **Introduction and Safety** on page 5 have been fully read and understood.



DANGER: Electrical hazard

Before starting work, check that the electric power supply is disconnected and locked out, to avoid unintentional restart of the pump set, the control panel and the auxiliary control circuit.



DANGER: Electrical hazard

After disconnecting the system from the power supply, wait 2 min for the discharge of the residual current.



WARNING:

Maintenance must be done by a technician possessing the technical-professional requirements outlined in the current regulations.



DANGER: Risk of falling from heights

When working at heights, use appropriate personal protective equipment.



WARNING:

Always wear personal protective equipment.



WARNING:

Always use suitable working tools.



WARNING:

In the case of liquids that are excessively hot or cold, pay attention to the risk of injury.



WARNING:

It is forbidden to leave the system unattended during maintenance.



WARNING:

It is mandatory to segregate the workplace with a red/white chain and to display appropriate danger and prohibition signs notifying that work is being carried out.

The disassembly or installation of the rotor in the motor casing generates a strong magnetic field:



DANGER: Magnetic hazard

The magnetic field may be dangerous for anyone wearing pacemakers, or any other medical devices sensitive to magnetic fields.

NOTE:

The magnetic field may attract metal debris on the rotor surface, causing damage to the same.

7.2 Maintenance every 3 months

Check that the expansion vessel is pre-charged correctly, see **First commissioning** on page 40.

7.3 Maintenance every 4000 hours of operation, or every year

Perform maintenance when one of the two limits is reached.

Maintenance with pump set running

Check:

1. That the pump set does not produce abnormal noises or vibrations.
2. That no liquid is leaking from the pump set and the piping system.
3. The tightening of all bolts.
4. The correspondence between the pressure shown by the gauges and that of the displays.

Maintenance with pump set off

1. Check:
 - The status of the cables
 - The tightness of the terminals in the control panel and the drive
 - That there are no signs of overheating and electric arcs on the terminal boxes and traces of humidity in the control panel and the drive.
 - Manually, the tripping of the control panel switches
 - The connection to the ground
 - The status of the fuses, if present
 - The status of the valves
 - The closing and opening of the valves
 - The status of the anti-vibration joints.
2. Clean:
 - The ventilation grilles of the control panel, if present
 - The fan cover
 - The drive dissipator
 - The stator casingand check the status of the cooling fan.
3. If the system has a ground protection device, press the test button.

7.4 Maintenance every 10000 hours of operation or every 2 years

When the first of the two limits is reached, replace the mechanical seal.

7.5 Maintenance every 17500 hours of operation or every 5 years

When the first of the two limits has been reached, replace the permanently lubricated bearings of the motor, if present.

7.6 Long periods of inactivity

1. Shut the on-off valve located on the discharge line.
2. Comply with the instructions on **Storage** page 14.
3. Before restarting the pump set:
 - Clean the filter
 - Check the status of the connections of the electric conductors on the pump set and the control panel.
4. Start the pump set complying with the instructions on **Use and operation** on page 39.

7.7 Identification of spare parts

Identify the spare parts with the product codes directly on the site spark.xylem.com. Contact Xylem or the Authorised Distributor for further technical information.

8 Troubleshooting



WARNING:

Maintenance must be done by a technician possessing the technical-professional requirements outlined in the current regulations.



WARNING:

If a fault cannot be corrected or is not mentioned, contact Xylem or the Authorised Distributor.

8.1 The control panel does not switch on

Cause	Solution
Main switch set to 0-OFF	Turn the switch to I-ON.
Electric power supply absent	Reset the power supply
Power supply cord is damaged	Replace the cable
Control panel ground protection device, if fitted, set to 0-OFF	Set the switch to I-ON: if it trips, identify the cause

8.2 The control panel protection device trips

The control panel ground protection device, if present, trips.

Cause	Solution
Protection device faulty	Replace the device
Power cable of the drive faulty or worn	Replace the cable
Pump set faulty	Contact Xylem or the Authorised Distributor, or send the pump set to an authorised workshop

8.3 The protection device has tripped

The ground protection device upstream of the control panel trips.

Cause	Solution
Protection device unsuitable or faulty	Check or repair the device
Power cable of the drive faulty or worn	Replace the cable
Differential current too high	Contact a qualified technician to have the electrical system modified
Pump set faulty	Contact Xylem or the Authorised Distributor, or send the pump set to an authorised workshop

8.4 The drive display does not switch on

Cause	Solution
Main control panel switch set to 0-OFF	Turn the switch to I-ON.
The drive switch in the control panel is set to 0-OFF	Turn the switch to I-ON.
Power supply cord is damaged	Replace the cable
Pump set faulty	Contact Xylem or the Authorised Distributor, or send the pump set to an authorised workshop
Electric power supply absent	Reset the power supply

8.5 The electric pump does not start automatically

Cause	Solution
Electric pump faulty	Contact Xylem or the Authorised Distributor, or send the electric pump to an authorised workshop

8.6 The pump set starts and stops too frequently

Cause	Solution
Expansion vessel damaged or defective	Repair or replace the expansion vessel
Expansion vessel incorrectly pre-charged	Set the new pressure pre-charge value according to the electric pump and setpoint
The expansion vessel pre-charge pressure is zero	Pre-charge the expansion vessel

8.7 The motor speed varies frequently but the liquid is not pumped

The motor speed varies frequently, the motor never stops and the liquid is not pumped

Cause	Solution
Loss of liquid from the non-return valve	Check the hydraulic system and the valve
Expansion vessel damaged or undersized	Repair or replace the expansion vessel

8.8 The electric pump works but the liquid is not pumped

Cause	Solution
No liquid at the suction or inside the electric pump	<ol style="list-style-type: none"> 1. Fill and prime the electric pump or the suction pipe 2. Open the on-off valves
Air inside the suction pipe or electric pump	<ol style="list-style-type: none"> 1. Vent the electric pump 2. Check the suction connections
Loss of pressure on the suction side	Check the NPSH and, if necessary, modify the system
Check valve blocked	Clean the valve
Clogged pipe	Clean the pipe
Foot valve blocked	Check the valve
Clogged foot valve filter	Clean the filter

8.9 The electric pumps are leaking

Cause	Solution
Mechanical seal worn or damaged	Replace the mechanical seal
Undue mechanical stress on the electric pumps	Support the piping system

8.10 The pump set produces excessive noise and/or vibrations

Cause	Solution
Plant resonance	Check the installation
Foreign bodies inside the pump set	Contact Xylem or the Authorised Distributor, or send the pump set to an authorised workshop
Cavitation	Check the suction conditions of the system
Pump tie rods not tight enough	Tighten the tie rod nuts
Air inside the pump set	<ul style="list-style-type: none"> • Bleed the pump set • Increase the liquid level in the suction tank • Remove any turbulences of the liquid in the suction area • Check the suction conditions
Return of liquid when the electric pump is not running	Check the non-return valve
Rotation of electric pump hindered	Check for undue mechanical stress on the electric pump
Motor-pump coupling incorrectly adjusted	Adjust the coupling
Anti-vibration joints on the piping system not suitable or absent	Install or replace the anti-vibration joints
Pump set faulty	Contact Xylem or the Authorised Distributor, or send the pump set to an authorised workshop

8.11 The electric pump is leaking at the mechanical seal

Cause	Solution
Mechanical seal damaged or worn	Contact Xylem or the Authorised Distributor, or send the pump set to an authorised workshop

8.12 The electric pump does not stop when the setpoint is reached

Cause	Solution
Check valve at the discharge blocked or clogged	Replace the valve
Expansion vessel damaged, not installed, undersized or incorrectly pre-charged	Install, replace or pre-charge the expansion vessel
Electric pump incorrectly set	Check the settings

8.13 The pump set does not generate the required pressure

Cause	Solution
On-off valves closed	Open the valves
Air in the suction pipe	<ol style="list-style-type: none"> 1. Eliminate the air 2. Prime the electric pumps
Undersized pump set	Contact Xylem or the Authorised Distributor, or send the pump set to an authorised workshop
The liquid requirements of the pump set are greater than the flow rate provided by the supply source	Increase the flow rate
Excessive negative suction head	Decrease the negative suction head
Excessive loss of pressure on the suction side	Modify the suction system and increase the diameter of the pipes
Foot check valve damaged	Replace the valve
Excessive loss of pressure in the delivery pipes and/or in the valve	Reduce the loss of liquid

8.14 The electric pump runs at maximum speed without stopping

Cause	Solution
Pressure setpoint not suitable for the system, the value is higher than the pressure that the electric pump can deliver	Set the new setpoint according to the performance of the electric pump
Sensor not connected or damaged	Check the hydraulic and electrical connection of the sensor, or replace it.

8.15 Only one electric pump of the multi-pump set is working

Cause	Solution
Electric pumps set differently from each other	Check: <ol style="list-style-type: none"> 1. The drive settings 2. The serial connection between the drives

8.16 The electric pump does not start with the liquid demand

Cause	Solution
The setpoint is set at zero	<ol style="list-style-type: none"> 1. Check the drive settings 2. Set the setpoint
Open float switch	Check: <ul style="list-style-type: none"> • The float switch: replace if faulty • The level of the liquid in the tank
Minimum pressure switch open	Check: <ul style="list-style-type: none"> • The pressure switch: replace if faulty • The presence of pressure at the suction • The contact connection • The calibrations

8.17 The piping system does not prime

Cause	Solution
Suction pipe of insufficient diameter and/or with too many changes in direction	Check the installation
Trapped distribution pipe effect	Check the installation
Clogged piping system	Remove the clogging
Air in the suction pipe	Complete a pressure test and check the tightness of the connections, joints and piping system
Foot valve clogged	Remove the clogging
Foot valve locked in closed or partially closed position	Replace the valve
On-off valves partially closed	Fully open the valves

8.18 Pump set error or alarm

Cause	Solution
Miscellaneous	See the Drive and Programming Manual

9 Specifications

9.1 Operating environment

Non-aggressive and non-explosive atmosphere.

NOTE:

Contact Xylem or the Authorised Distributor in case of:

- Dust and/or sand
 - Sea salt
 - Vibrations
 - Strong magnetic fields
 - Chemical pollution
 - Ionizing radiations.
-

Temperature

From 5 to 40°C (41-104°F), unless otherwise indicated on the data plate of the electric motor and the electric pump.

Relative air humidity

< 50% at 40°C (104°F).

NOTE:

If the humidity exceeds the stated limits, contact Xylem or the Authorised Distributor.

Elevation

< 1000 m (3280 ft) above sea level.

NOTE: Motor overheating danger

If the pump set is exposed to temperatures or installed at an altitude greater than those stated, reduce the power output of the motors in line with the coefficients indicated in the table.

Otherwise, replace the motors with more powerful ones.

If the pump set is installed at an altitude exceeding 2000 m (6600 ft), contact Xylem or the Authorised Distributor.

Altitude m (ft)	Power reduction coefficient
1000÷1500 (3300÷4900)	0.97
1500÷2000 (4900÷6600)	0.95

9.2 Liquid temperature

From 5 to 60°C (41-140°F), unless otherwise indicated on the data plate of the electric motor and the electric pump.

9.3 Maximum operating pressure of the electric pumps

The maximum operating pressure of some models depends on the temperature of the liquid: please refer to the manuals of the electric pumps.
 Comply with the operating limits of the expansion vessel, if installed: refer to the expansion vessel manual.

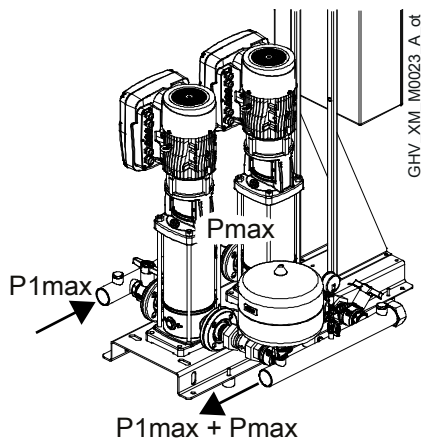

Data	Description
P1max	Maximum input pressure
Pmax	Maximum pressure generated by the electric pumps
PN	Maximum operating pressure

Note: $P1max + Pmax \leq PN$

9.4 Maximum number of starts per hour

$\leq 4/h.$

9.5 Electrical specifications

Features	Description
Permitted tolerances for the pump set power supply voltage	<ul style="list-style-type: none"> • 3x400 Vac $\pm 10\%$ 50/60 Hz • 3x230 Vac $\pm 10\%$ 50/60 Hz Phases: 3 + PE
Permissible tolerance for the power supply voltage of auxiliary circuits	24 Vac $\pm 10\%$
Rated current and maximum power output	See the data plate
Control panel protection class	IP 55 Note: for control panels larger than 1300x600x300 mm the IP 55 rating is the responsibility of the installer
Electric pump protection class	IP 55

9.6 Radio frequency characteristics

Features	Description
Technology	Wireless Low Energy 5.2
Band	2.4 GHz ISM
RF	≤ 4.5 mW (6.5 dBm)

9.7 Characteristics of inputs and outputs

Name	Quantity	Features
Communication port	2	RS-485
Digital input	5	<ul style="list-style-type: none"> Floating/NPN contact, open manifold/drain open, to GND Internal polarisation +24 Vdc, current limited to 6 mA max. Protection from -0.5 Vdc to +30 Vdc, ±15 mA max.
Analog input	4	<ul style="list-style-type: none"> Configurable or 0-20 mA current, or 0-10 V voltage 24V signal for sensor power supply with current limitation 60 mA
Analogue output	1	Configurable as either 0-20 mA current signal or 0-10 V voltage signal
Relay	2	With NC and NO changeover contact: <ul style="list-style-type: none"> Relay 1 up to 240 Vac 0.25 A or 30 Vdc 2 A Relay 2 up to 30 Vac 0.25 A or 30 Vdc 2 A



WARNING:

If relay 1 is connected to a voltage higher than 30 Vac, disconnect and do not use the terminals of relay 2.

9.8 Sound pressure

Measured in free field at a distance of one metre from the pump set, operating without load at 3600 min⁻¹.

Size	Powers, kW	LpA, dB ± 2
B	3, 4, 5.5	< 75
C	5.5, 7.5, 11	< 82
D	11, 15, 18.5	< 82

10 Disposal

10.1 Precautions



WARNING:

The pump set must be disposed of through approved companies specialised in the sorting of the different types of materials: steel, copper, plastic, lithium, ferrite etc...



WARNING:

It is prohibited to dispose of lubricating fluids and other hazardous substances in the environment.

10.2 WEEE (EU/EEA)

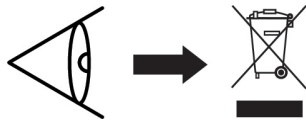

INFORMATION TO USERS pursuant to art. 14 of the Directive 2012/19/EU of the European Parliament and of the Council of 4 July 2012 on waste electrical and electronic equipment (WEEE). The crossed bin symbol on the appliance or on its packaging indicates that the product at the end of its useful life must be collected separately and not disposed of together with other mixed urban waste. Appropriate separate collection for the subsequent start-up of the disused equipment for recycling, treatment and environmentally compatible disposal helps to avoid possible negative effects on the environment and on health and favours the re-use and / or recycling of the materials of which the equipment is composed.

WEEE from users other than private households (classification according to product type, use and current local laws): the separate collection of this equipment at the end of its life is organized and managed by the producer of EEE as per Directive 2012/19/EU.

The user who wants to get rid of this equipment can then contact the producer and follow the system that it has adopted to allow the separate collection of equipment at the end of life or select an organization independently authorized to manage waste.

10.3 WEEE (UK)

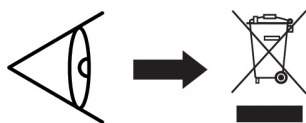

INFORMATION TO USERS pursuant to art. 44 of the The Waste Electrical and Electronic Equipment Regulations 2013 (S. I. 2013 No. 3113). The crossed bin symbol on the appliance or on its packaging indicates that the product at the end of its useful life must be collected separately and not disposed of together with other mixed urban waste. Appropriate separate collection for the subsequent start-up of the disused equipment for recycling, treatment and environmentally compatible disposal helps to avoid possible negative effects on the environment and on health and favours the re-use and / or recycling of the materials of which the equipment is composed.

WEEE from users other than private households (classification according to product type, use and current local laws): the separate collection of this equipment at the end of its life is organized and managed by the producer of EEE as per WEEE Regulations 2013.

The user who wants to get rid of this equipment can then contact the producer and follow the system that it has adopted to allow the separate collection of equipment at the end of life or select an organization independently authorized to manage waste.

11 Declarations

Refer to the specific marking declaration found on the product.



EC Declaration of Conformity (Original)

Xylem Service Italia S.r.l., with headquarters in Via Vittorio Lombardi 14 - 36075 Montecchio Maggiore VI - Italy, hereby declares that the product

GHV... pumping set with SVX electric pumps, in one of the various versions/options as per catalogue (see the label on the first page)

fulfils the relevant provisions of the following European Directives

- Machinery 2006/42/EC and subsequent amendments (ANNEX II - natural or legal person authorised to compile the technical file: Xylem Service Italia S.r.l.)

and the following technical standards

- EN ISO 12100:2010, EN 60204-1:2018.

Montecchio Maggiore, 16/05/2023

Peter Björnsson
Managing Director

rev.00

EU Declaration of Conformity (n. 72)

1. EMC - Apparatus/Product model: GHV... (see the label on the first page)
RoHS - Unique identification of the EEE: GHV...SVX...
2. Name and address of the manufacturer:
Xylem Service Italia S.r.l.
Via Vittorio Lombardi 14
36075 Montecchio Maggiore VI
Italy
3. This declaration of conformity is issued under the sole responsibility of the manufacturer.
4. Object of the declaration:
GHV... pumping set with SVX electric pumps, in one of the various versions/options as per catalogue (see the label on the first page)
5. The object of the declaration described above is in conformity with the relevant Union harmonization legislation:
 - 2014/30/EU Directive of 26 February 2014 and subsequent amendments (electromagnetic compatibility)
 - 2011/65/EU Directive of 8 June 2011 and subsequent amendments, including the 2015/863/EU Directive (restriction of the use of certain hazardous substances in electrical and electronic equipment).

6. References to the relevant harmonized standards used or references to the other technical specifications, in relation to which conformity is declared:
 - EN 61000-6-1:2007, EN IEC 61000-6-1:2019, EN 61000-6-2:2005, EN IEC 61000-6-2:2019, EN 61000-6-3:2007+A1:2011, EN IEC 61000-6-3:2021, EN 61000-6-4:2007+A1:2011, EN IEC 61000-6-4:2019
 - EN IEC 63000:2018.
7. Notified body: -
8. Additional information:
RoHS - Annex III - Applications exempted from the restrictions: lead as an alloying element in steel, aluminium, copper alloys [6 a), 6 b), 6 c)], in solders and in electrical/electronic components [7 a), 7 c)-I].

Signed for and on behalf of:
Xylem Service Italia S.r.l.

Montecchio Maggiore, 16/05/2023

Peter Björnsson
Managing Director

rev.00



Accessories

Optimize™ and CCD 401 (Cloud Connect Device 4G).

Please refer to the specific documentation and the manufacturer's declaration of conformity included in the scope of delivery.

Lowara is a trademark of Xylem Inc. or one of its subsidiaries.

Hydrovar is a trademark of Xylem Inc. or one of its subsidiaries.

Apple, Apple Logo, App Store and iPhone are trademarks of Apple Inc..

IOS® is a registered trademark of Cisco Systems, Inc. and/or its subsidiaries in the United States and in other countries, used by Apple Inc. under licence.

Google Play, Google Play logo and Android are trademarks of Google LLC.



UK Declaration of Conformity (Original)

Xylem Service Italia S.r.l., with headquarters in Via Vittorio Lombardi 14 - 36075 Montecchio Maggiore VI - Italy, hereby declares that the product

GHV... pumping set, with SVX electric pumps, in one of the various versions/options as per catalogue (see the label on the first page)

fulfils the relevant provisions of the UK legislative acts

- S.I. 2008/1597 - Supply of Machinery (Safety) Regulations 2008 and subsequent amendments (Schedule 2 - Part 2 - Annex II - natural or legal person authorised to compile the technical file: Xylem Service Italia S.r.l.)

and the following technical standards

- EN ISO 12100:2010, EN 60204-1:2018.

Montecchio Maggiore, 16/05/2023

Peter Björnsson
Managing Director

rev.00



UK Declaration of Conformity (n. 72)

1. EMC - Apparatus/Product model: GHV... (see the label on the first page)
RoHS - Unique identification of the EEE: GHV...SVX...
2. Name and address of the manufacturer:
Xylem Service Italia S.r.l.
Via Vittorio Lombardi 14
36075 Montecchio Maggiore VI
Italy
3. This declaration of conformity is issued under the sole responsibility of the manufacturer.
4. Object of the declaration:
GHV... pumping set, with SVX electric pumps, in one of the various versions/options as per catalogue (see the label on the first page)
5. The object of the declaration described above is in conformity with the relevant UK legislative acts:
 - S.I. 2016/1091 - The Electromagnetic Compatibility Regulations 2016 and subsequent amendments
 - S.I. 2012/3032 - The Restriction of the Use of Certain Hazardous Substances in Electrical and Electronic Equipment Regulations 2012 and subsequent amendments.
6. References to the relevant designated standards used or references to the other technical specifications, in relation to which conformity is declared:
 - EN 61000-6-1:2007, EN IEC 61000-6-1:2019, EN 61000-6-2:2005, EN IEC 61000-6-2:2019, EN 61000-6-3:2007+A1:2011, EN IEC 61000-6-3:2021, EN 61000-6-4:2007+A1:2011, EN IEC 61000-6-4:2019.
 - EN IEC 63000:2018.
7. Approved body: -
8. Additional information:
RoHS - Annex III of 2011/65/EU - Applications exempted from restrictions: lead as an alloying element in steel, aluminium, copper alloys [6(a), 6(b), 6(c)], in solders and in electrical/electronic components [7(a), 7(c)-I].

Signed for and on behalf of:
Xylem Service Italia S.r.l.

Montecchio Maggiore, 16/05/2023

Peter Björnsson
Managing Director

rev.00

Accessories

Optimize™ and CCD 401 (Cloud Connect Device 4G).

Please refer to the specific documentation and manufacturer's declaration of conformity included in the delivery.

Lowara is a trademark of Xylem Inc. or one of its subsidiaries.

Hydrovar is a trademark of Xylem Inc. or one of its subsidiaries.

Apple, Apple Logo, App Store and iPhone are trademarks of Apple Inc..

IOS® is a registered trademark of Cisco Systems, Inc. and/or its affiliates in the United States and certain other countries, used under license by Apple Inc..

Google Play, Google Play logo and Android are trademarks of Google LLC.

12 Warranty

For information on the warranty refer to the commercial documentation.

Xylem |'zīləm|

- 1) The tissue in plants that brings water upward from the roots;
- 2) A leading global water technology company.

We're a global team unified in a common purpose: creating innovative solutions to meet our world's water needs. Developing new technologies that will improve the way water is used, conserved, and re-used in the future is central to our work. We move, treat, analyze, and return water to the environment, and we help people use water efficiently, in their homes, buildings, factories and farms. In more than 150 countries, we have strong, long-standing relationships with customers who know us for our powerful combination of leading product brands and applications expertise, backed by a legacy of innovation.

For more information on how Xylem can help you, go to www.xylem.com



Xylem Service Italia S.r.l.
Via Vittorio Lombardi 14
36075 - Montecchio Maggiore (VI) - Italy
xylem.com/lowara

Lowara is a trademark of Xylem Inc. or one of its subsidiaries.
© 2023 Xylem, Inc. Cod. 001086158EN rev.B ed.01/2024