

ITEM NO.	PART NUMBER	DESCRIPTION	QTY.
1	VTN80	800L UNDERGROUND TANK	1
2	MCS-012	SQUARE GALVANISED MANHOLE COVER	1

DESIGN DATA	
DESIGN PRESSURE: ATMOSPHERIC	MAXIMUM CAPACITY (LTRS):
DESIGN TEMPERATURE: 40°C	WORKING CAPACITY (LTRS):
WORKING PRESSURE: ATMOSPHERIC	APPROX. WEIGHT FULL (KGS):
WORKING TEMPERATURE: 40°C	APPROX. WEIGHT EMPTY (KGS):
MOULDED LIFTING LUGS: 4 - 0°, 90°, 180° & 270°	
METHOD OF SUPPORT: FIRM, FLAT, FULLY SUPPORTING BASE OF CONCRETE OR OTHER SUITABLE MATERIAL	

MATERIAL DATA
MATERIALS OF CONSTRUCTION: MATRIX REVOLVE N-307. REVOLVE IS A HIGH DENSITY (0.939 g/cm3), LOW MELT (3.5 g/ 10 min) HEXENE POLYETHYLENE GRADE FOR ROTOMOULDING. THE GRADE IS FULLY PROTECTED AGAINST THERMAL AND LIGHT DEGRADATION: N-307 IS UV10 STABILISED.

INSPECTION AND TESTING
WORKS TEST: ALL TANKS ARE THICKNESS TESTED BY ULTRASOUND AFTER DEMOULD. IN ADDITION, AIR SUPPORTED LEAK TEST ARE CARRIED OUT ON FLANGE LINES.

NOTE SECTION

	NAME	SIGNATURE	DATE
DRAWN	LC	L.Crane	10/08/2023
CHECKED			

UNLESS OTHERWISE SPECIFIED:
DIMENSIONS ARE IN MILLIMETERS
SURFACE FINISH: MDPE
TOLERANCES: ±3%



3RD ANGLE PROJECTION

DO NOT SCALE DRAWING REVISION: A

ENDURAMAXX[®]
FLUID MANAGEMENT INNOVATION

DWG TITLE:
800L NON-POTABLE UNDERGROUND TANK

DWG NO: VTR80-A-800L-UNDERGROUND A3

SCALE: 1:17 SHEET 1 OF 1

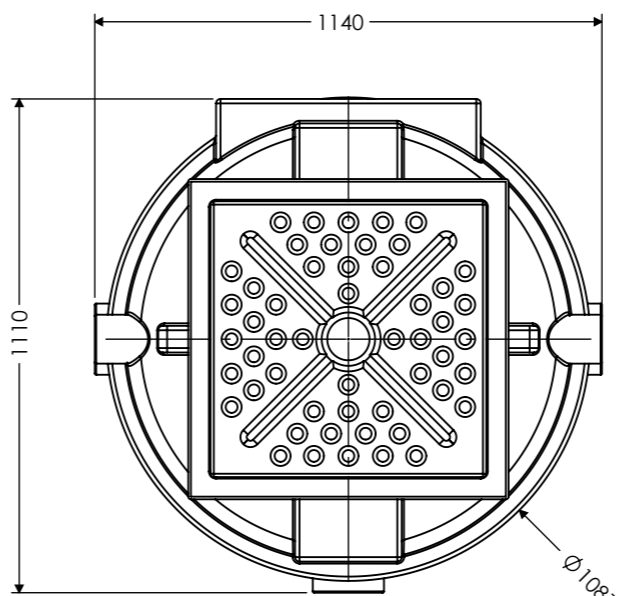

PLAN VIEW

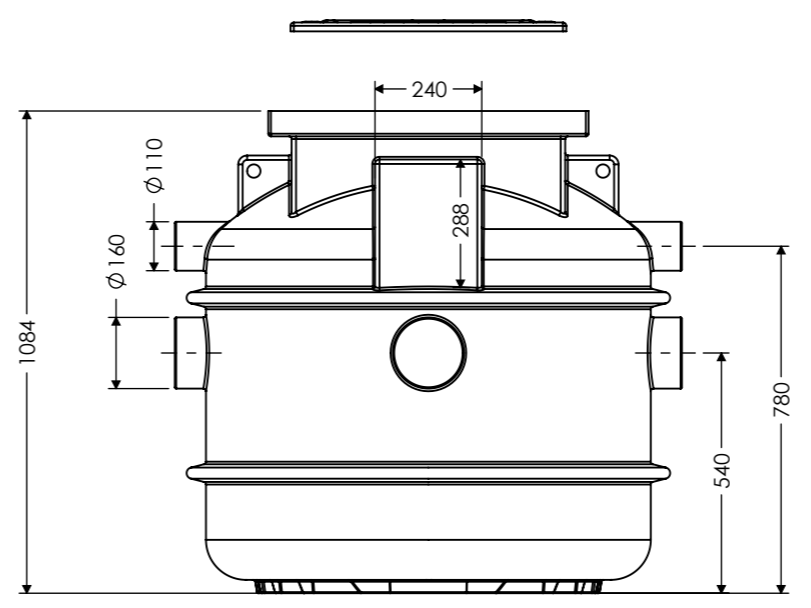

FRONT VIEW

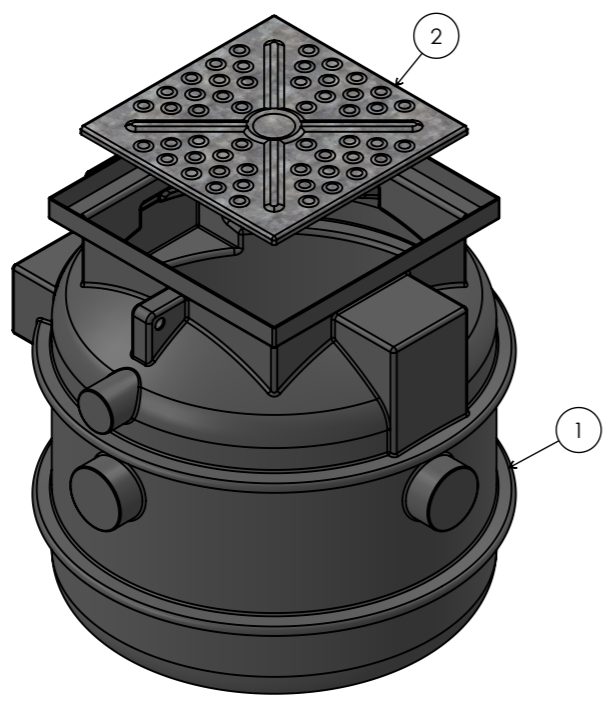

LEFT ISO VIEW