

ITEM NO.	PART NUMBER	DESCRIPTION	QTY.
1	VTN1000	10,000L UNDERGROUND TANK	1
2	-	250mm NON-POTABLE TURRET EXTENSION	1
3	MCS-012	SQUARE GALVANISED MANWAY COVER	1

DESIGN DATA	
DESIGN PRESSURE: ATMOSPHERIC	MAXIMUM CAPACITY (LTRS):
DESIGN TEMPERATURE: 40°C	WORKING CAPACITY (LTRS):
WORKING PRESSURE: ATMOSPHERIC	APPROX. WEIGHT FULL (KGS):
WORKING TEMPERATURE: 40°C	APPROX. WEIGHT EMPTY (KGS):
MOULDED LIFTING LUGS: 4 - 0°, 90°, 180° & 270°	
METHOD OF SUPPORT: FIRM, FLAT, FULLY SUPPORTING BASE OF CONCRETE OR OTHER SUITABLE MATERIAL	

MATERIAL DATA
MATERIALS OF CONSTRUCTION:
MATRIX REVOLVE N-307. REVOLVE IS A HIGH DENSITY (0.939 g/cm <sup>3</sup> ), LOW MELT (3.5 g/ 10 min) HEXENE POLYETHYLENE GRADE FOR ROTOMOULDING. THE GRADE IS FULLY PROTECTED AGAINST THERMAL AND LIGHT DEGRADATION: N-307 IS UV10 STABILISED.

INSPECTION AND TESTING
WORKS TEST: ALL TANKS ARE THICKNESS TESTED BY ULTRASOUND AFTER DEMOULD. IN ADDITION, AIR SUPPORTED LEAK TEST ARE CARRIED OUT ON FLANGE LINES.

NOTE SECTION

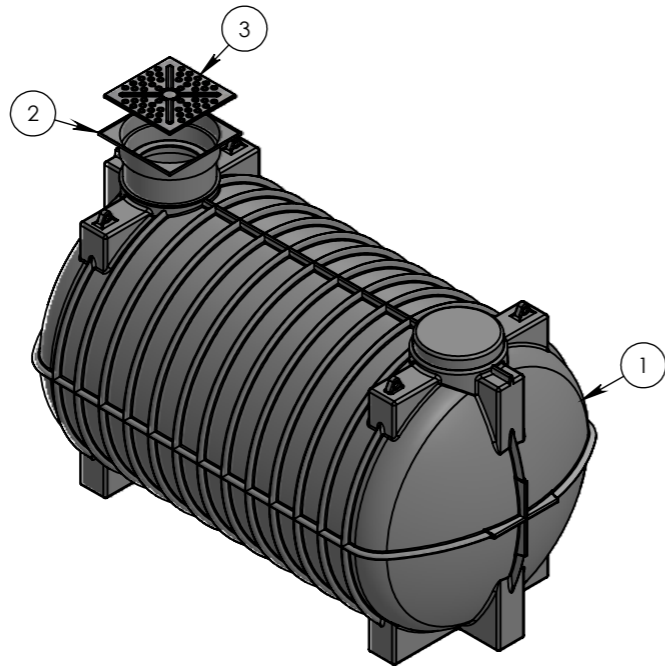

LEFT ISO VIEW

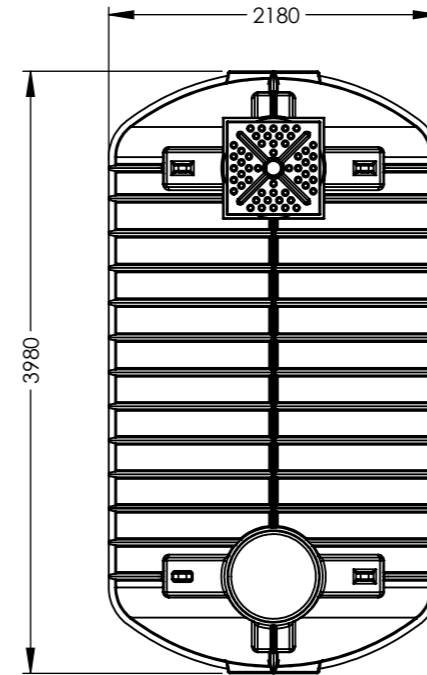

PLAN VIEW

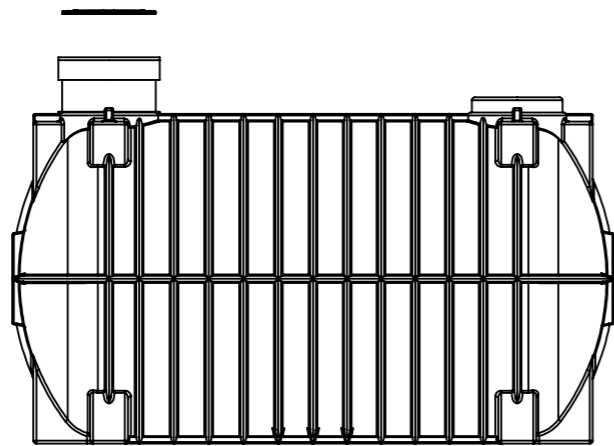

LRFT VIEW

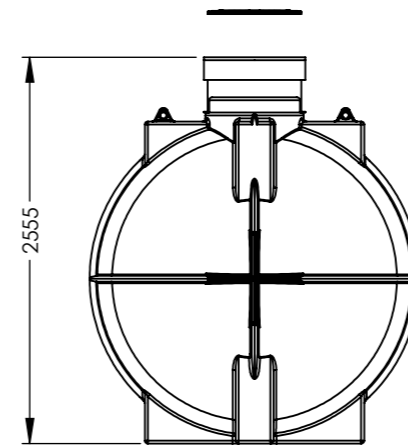

FRONT VIEW

	NAME	SIGNATURE	DATE
DRAWN	LC	L.Crane	19/08/2022
CHECKED			

UNLESS OTHERWISE SPECIFIED: DIMENSIONS ARE IN MILLIMETERS SURFACE FINISH: MDPE TOLERANCES: ±3%	 3RD ANGLE PROJECTION
---	--------------------------

DO NOT SCALE DRAWING	REVISION: -
----------------------	-------------



DWG TITLE:	10,000L NON-POTABLE UNDERGROUND TANK
------------	--------------------------------------

DWG NO: VTR-1000-10000-UNDERGROUND	A3
------------------------------------	----

SCALE: 1:50	SHEET 1 OF 1
-------------	--------------