

Qty.	Description
1	<p data-bbox="199 338 561 369">CM 3-4 A-R-I-E-AQQE C-A-A-N</p> <div data-bbox="236 439 534 607">  </div> <p data-bbox="592 629 1075 654" style="text-align: center;">Note! Product picture may differ from actual product</p> <p data-bbox="199 663 469 687">Product No.: 96961045</p> <p data-bbox="199 719 1452 797">Compact, reliable, horizontal, multistage, end-suction centrifugal pump with axial suction port and radial discharge port. Pump materials in contact with the liquid are in stainless steel. The mechanical shaft seal is a special designed, unbalanced O-ring seal. Pipework connection is via internal Whitworth pipe threads, Rp (ISO 7/1).</p> <p data-bbox="199 864 1094 889">The pump is fitted with a 1-phase, foot-mounted, fan-cooled asynchronous motor.</p> <p data-bbox="199 954 316 978">Controls:</p> <p data-bbox="199 981 638 1008">Frequency converter: NONE</p> <p data-bbox="199 1043 288 1068">Liquid:</p> <p data-bbox="199 1070 778 1189">Pumped liquid: Water Liquid temperature range: -20 .. 120 °C Selected liquid temperature: 20 °C Density at selected liquid temperature: 998.2 kg/m³</p> <p data-bbox="199 1223 328 1247">Technical:</p> <p data-bbox="199 1249 820 1397">Pump speed on which pump data are based: 2900 rpm Rated flow: 3.1 m³/h Rated head: 27.39 m Code for shaft seal: AQQE Curve tolerance: ISO9906:2012 3B</p> <p data-bbox="199 1431 320 1456">Materials:</p> <p data-bbox="199 1458 727 1632">Pump housing: Stainless steel EN 1.4301 AISI 304 Impeller: Stainless steel EN 1.4301 AISI 304</p> <p data-bbox="199 1666 344 1691">Installation:</p> <p data-bbox="199 1693 740 1930">Range of ambient temperature: -20 .. 55 °C Maximum operating pressure: 16 bar Max pressure at stated temp: 16 bar / 90 °C 10 bar / 120 °C Type of connection: Rp Size of inlet connection: 1 inch Size of outlet connection: 1 inch Outlet position: 12</p> <p data-bbox="199 1964 381 1989">Electrical data:</p> <p data-bbox="199 1991 644 2107">Motor standard: IEC Frame size: 71B Rated power - P2: 0.5 kW Mains frequency: 50 Hz</p>

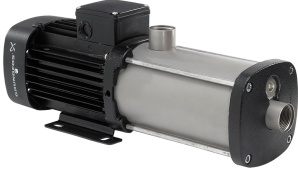

Company name:

Created by:

Phone:

Date: 25/09/2019

Qty.	Description
	<p>Phases: 1 Rated voltage: 220-240 V Service factor: 1.00 Rated current: 3.1-2.8 A Starting current: 530-530 % Rated speed: 2730-2740 rpm Enclosure class (IEC 34-5): IP55 Insulation class (IEC 85): F Built-in motor protection: PTO</p> <p>Others: Terminal box position: 12 Minimum efficiency index, MEI : 0.7 Net weight: 12.8 kg Gross weight: 15.3 kg Approvals: CE,WRAS,ACS,TR,EAC Country of origin: HU Custom tariff no.: 84137075</p>

96961045 CM 3-4 A-R-I-E-AQQE C-A-A-N 50 Hz

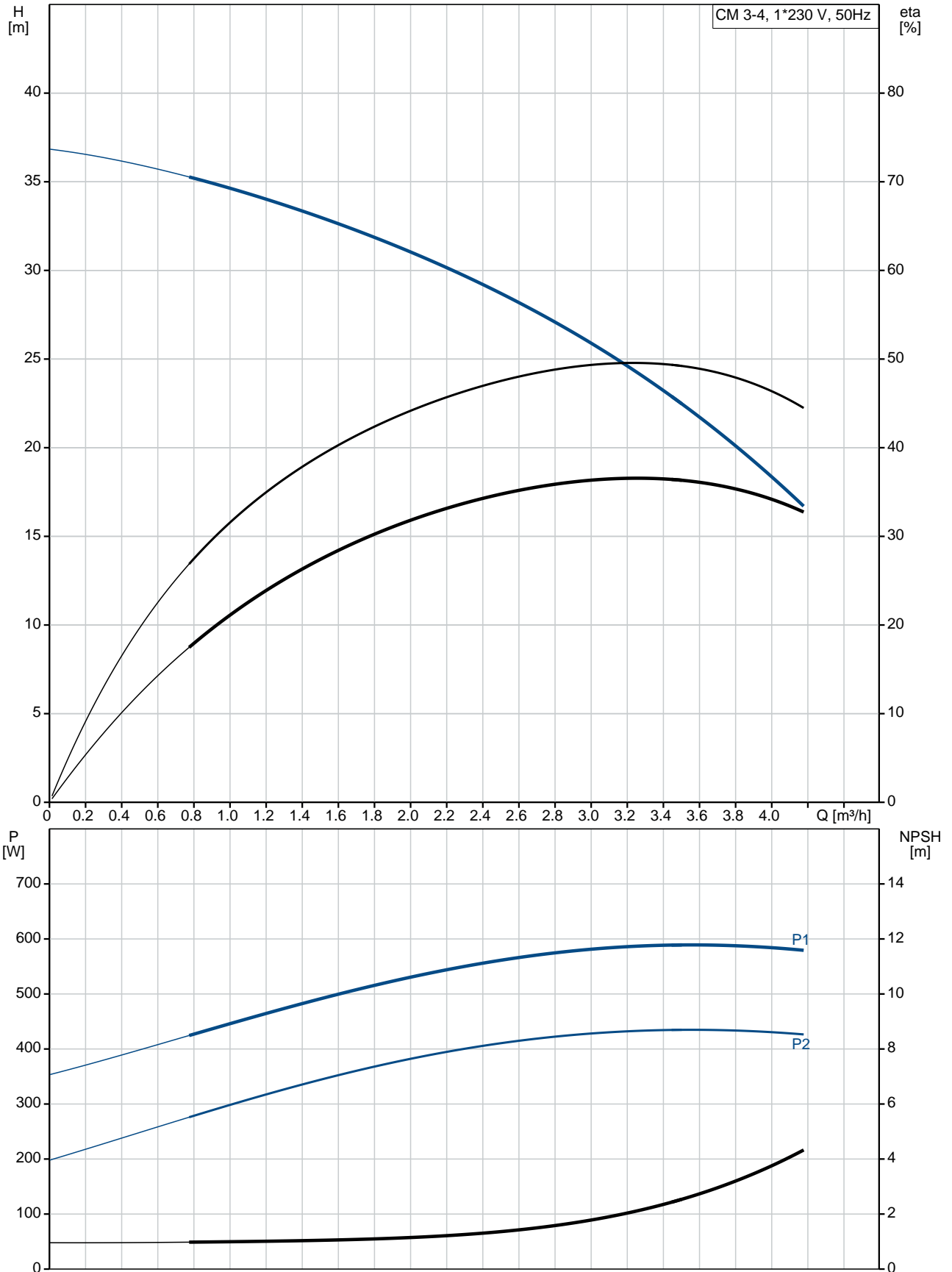

Description	Value
General information:	
Product name:	CM 3-4 A-R-I-E-AQQE C-A-A-N
Product No:	96961045
EAN number:	5700314824006
	5700314824006
Price:	589,00 GBP
Technical:	
Pump speed on which pump data are based:	2900 rpm
Rated flow:	3.1 m ³ /h
Rated head:	27.39 m
Impellers:	4
Code for shaft seal:	AQQE
Curve tolerance:	ISO9906:2012 3B
Pump version:	A
Model:	A
Materials:	
Pump housing:	Stainless steel
	EN 1.4301
	AISI 304
Impeller:	Stainless steel
	EN 1.4301
	AISI 304
Material code:	I
Code for rubber:	E
Installation:	
Range of ambient temperature:	-20 .. 55 °C
Maximum operating pressure:	16 bar
Max pressure at stated temp:	16 bar / 90 °C
	10 bar / 120 °C
Type of connection:	Rp
Size of inlet connection:	1 inch
Size of outlet connection:	1 inch
Outlet position:	12
Connect code:	R
Liquid:	
Pumped liquid:	Water
Liquid temperature range:	-20 .. 120 °C
Selected liquid temperature:	20 °C
Density at selected liquid temperature:	998.2 kg/m ³
Electrical data:	
Motor standard:	IEC
Frame size:	71B
Rated power - P2:	0.5 kW
Mains frequency:	50 Hz
Phases:	1
Rated voltage:	220-240 V
Service factor:	1.00
Rated current:	3.1-2.8 A
Starting current:	530-530 %
Rated speed:	2730-2740 rpm
Enclosure class (IEC 34-5):	IP55
Insulation class (IEC 85):	F
Built-in motor protection:	PTO
Controls:	
Frequency converter:	NONE
Others:	
Terminal box position:	12

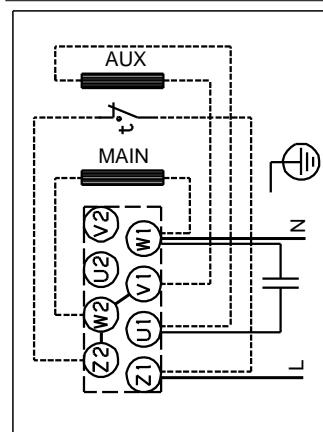
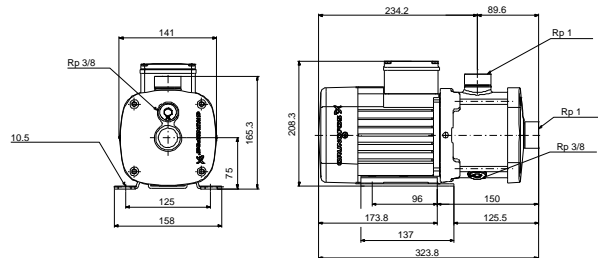
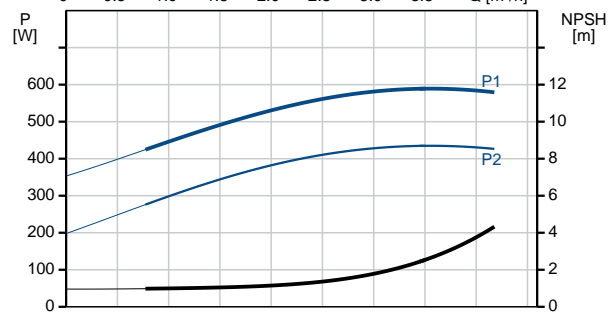
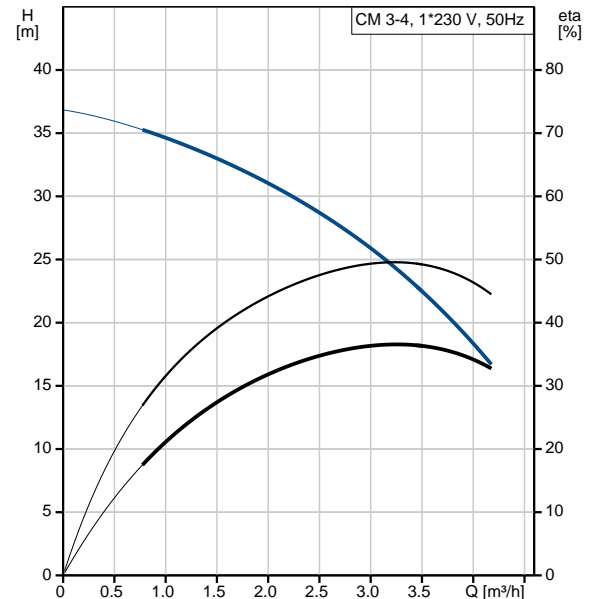



Company name:

Created by:

Phone:

Date:

25/09/2019

Description	Value
Minimum efficiency index, MEI :	0.7
Net weight:	12.8 kg
Gross weight:	15.3 kg
Approvals:	CE,WRAS,ACS,TR,EAC
Country of origin:	HU
Custom tariff no.:	84137075

96961045 CM 3-4 A-R-I-E-AQQE C-A-A-N 50 Hz

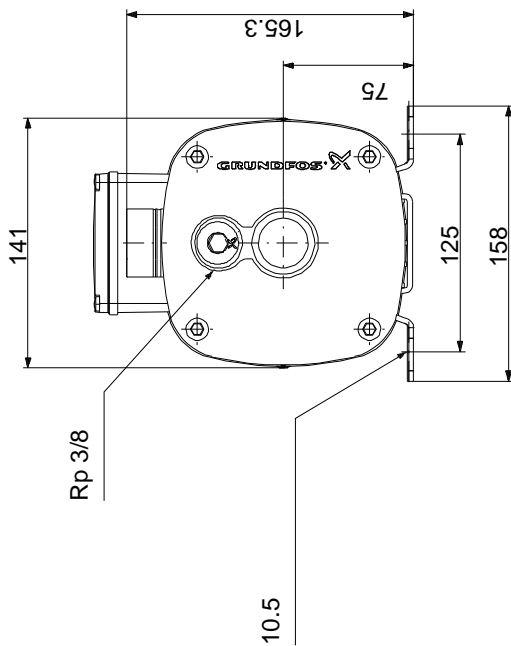
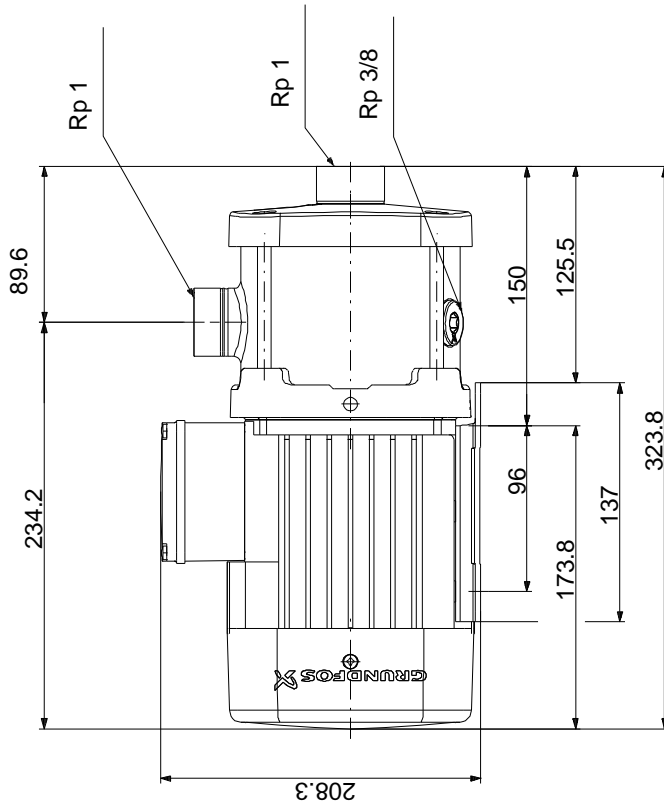

Note! All units are in [mm] unless others are stated.
Disclaimer: This simplified dimensional drawing does not show all details.

96961045 CM 3-4 A-R-I-E-AQQE C-A-A-N 50 Hz

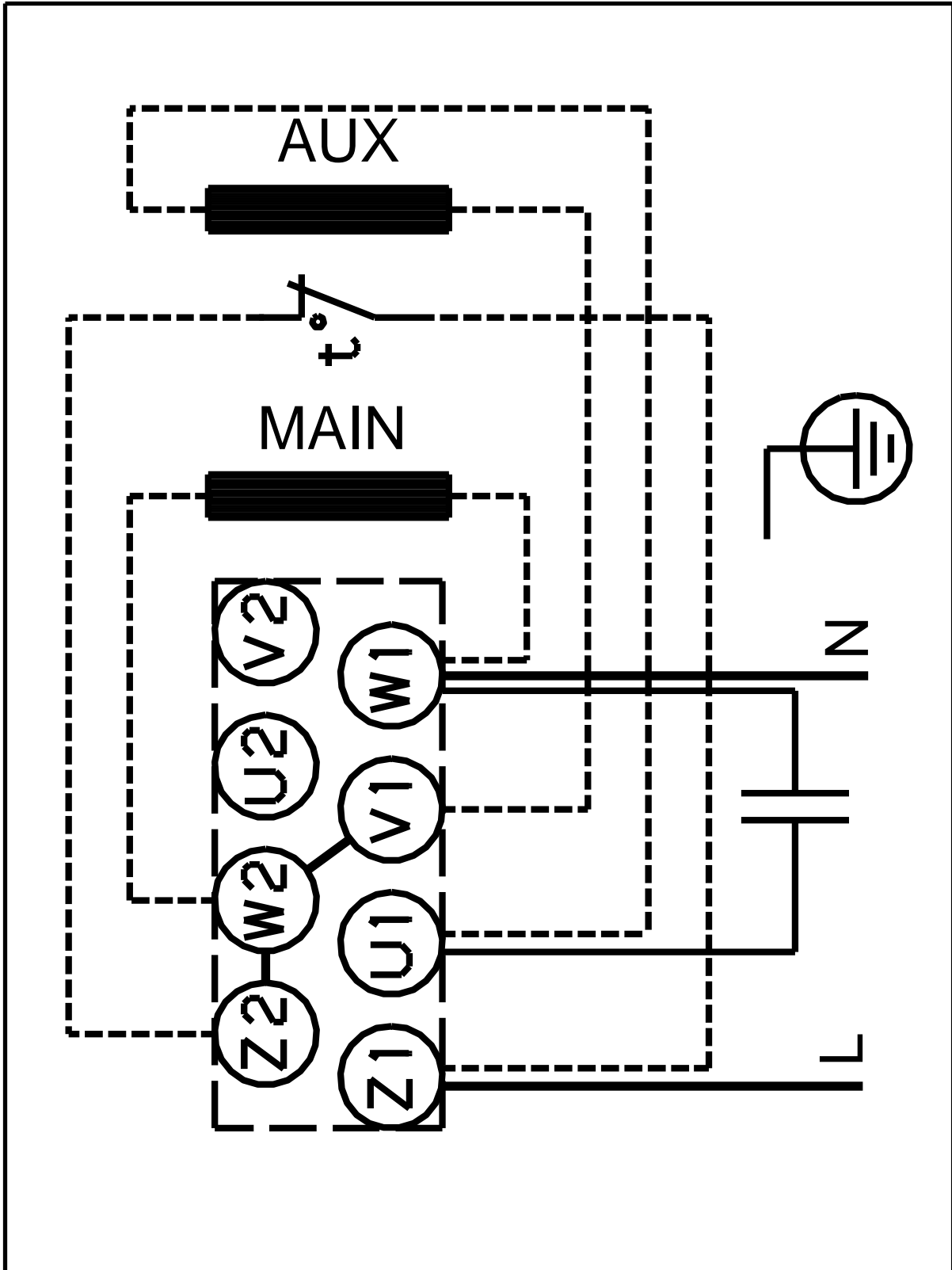

Note! All units are in [mm] unless others are stated.