

Qty.	Description
1	<p data-bbox="199 338 574 369">CM 10-2 A-R-I-E-AQQE C-A-A-N</p> <div data-bbox="236 439 534 607">  </div> <p data-bbox="592 629 1077 654" style="text-align: center;">Note! Product picture may differ from actual product</p> <p data-bbox="199 663 470 687">Product No.: 96946004</p> <p data-bbox="199 719 1452 797">Compact, reliable, horizontal, multistage, end-suction centrifugal pump with axial suction port and radial discharge port. Pump materials in contact with the liquid are in stainless steel. The mechanical shaft seal is a special designed, unbalanced O-ring seal. Pipework connection is via internal Whitworth pipe threads, Rp (ISO 7/1).</p> <p data-bbox="199 864 1093 889">The pump is fitted with a 1-phase, foot-mounted, fan-cooled asynchronous motor.</p> <p data-bbox="199 954 311 978">Controls:</p> <p data-bbox="199 981 638 1008">Frequency converter: NONE</p> <p data-bbox="199 1043 287 1068">Liquid:</p> <p data-bbox="199 1070 638 1097">Pumped liquid: Water</p> <p data-bbox="199 1099 710 1126">Liquid temperature range: -20 .. 120 °C</p> <p data-bbox="199 1128 630 1155">Selected liquid temperature: 20 °C</p> <p data-bbox="199 1158 774 1184">Density at selected liquid temperature: 998.2 kg/m³</p> <p data-bbox="199 1220 327 1245">Technical:</p> <p data-bbox="199 1247 821 1274">Pump speed on which pump data are based: 2900 rpm</p> <p data-bbox="199 1276 654 1303">Rated flow: 10 m³/h</p> <p data-bbox="199 1305 662 1332">Rated head: 24.61 m</p> <p data-bbox="199 1335 638 1361">Code for shaft seal: AQQE</p> <p data-bbox="199 1364 766 1391">Curve tolerance: ISO9906:2012 3B</p> <p data-bbox="199 1426 319 1451">Materials:</p> <p data-bbox="199 1453 726 1541">Pump housing: Stainless steel EN 1.4301 AISI 304</p> <p data-bbox="199 1543 726 1630">Impeller: Stainless steel EN 1.4301 AISI 304</p> <p data-bbox="199 1666 343 1691">Installation:</p> <p data-bbox="199 1693 694 1720">Range of ambient temperature: -20 .. 55 °C</p> <p data-bbox="199 1722 638 1749">Maximum operating pressure: 16 bar</p> <p data-bbox="199 1751 742 1812">Max pressure at stated temp: 16 bar / 90 °C 10 bar / 120 °C</p> <p data-bbox="199 1814 678 1930">Type of connection: Rp Size of inlet connection: 1 1/2 inch Size of outlet connection: 1 1/2 inch Outlet position: 12</p> <p data-bbox="199 1966 375 1991">Electrical data:</p> <p data-bbox="199 1993 614 2020">Motor standard: IEC</p> <p data-bbox="199 2022 614 2049">Frame size: 90A</p> <p data-bbox="199 2051 646 2078">Rated power - P2: 1.3 kW</p> <p data-bbox="199 2080 630 2107">Mains frequency: 50 Hz</p>

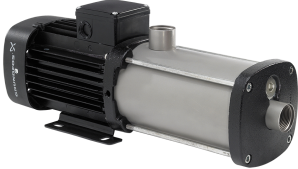

Company name:

Created by:

Phone:

Date:

25/09/2019

Qty.	Description
------	-------------

	Phases: 1
	Rated voltage: 220-240 V
	Service factor: 1.00
	Rated current: 8.4-8.0 A
	Starting current: 340-340 %
	Rated speed: 2710 rpm
	Enclosure class (IEC 34-5): IP55
	Insulation class (IEC 85): F
	Built-in motor protection: PTO
	Others:
	Terminal box position: 12
	Minimum efficiency index, MEI : 0.52
	Net weight: 24.8 kg
	Gross weight: 27.3 kg
	Approvals: CE,WRAS,ACS,TR,EAC
	Country of origin: HU
	Custom tariff no.: 84137075

96946004 CM 10-2 A-R-I-E-AQQE C-A-A-N 50 Hz

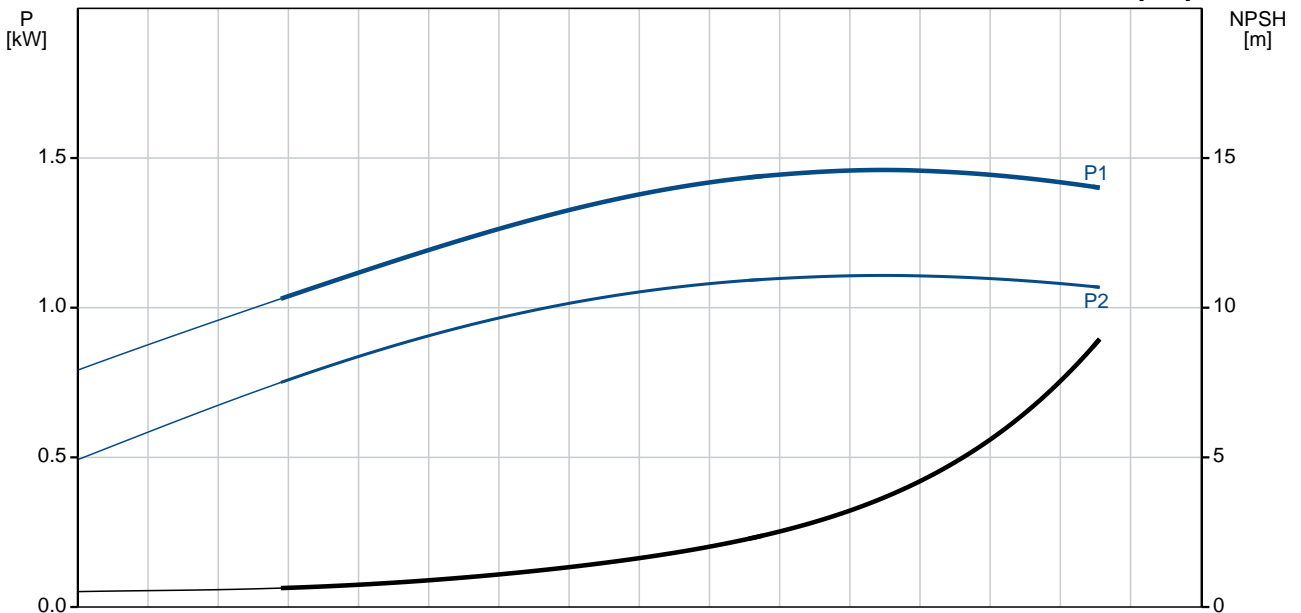
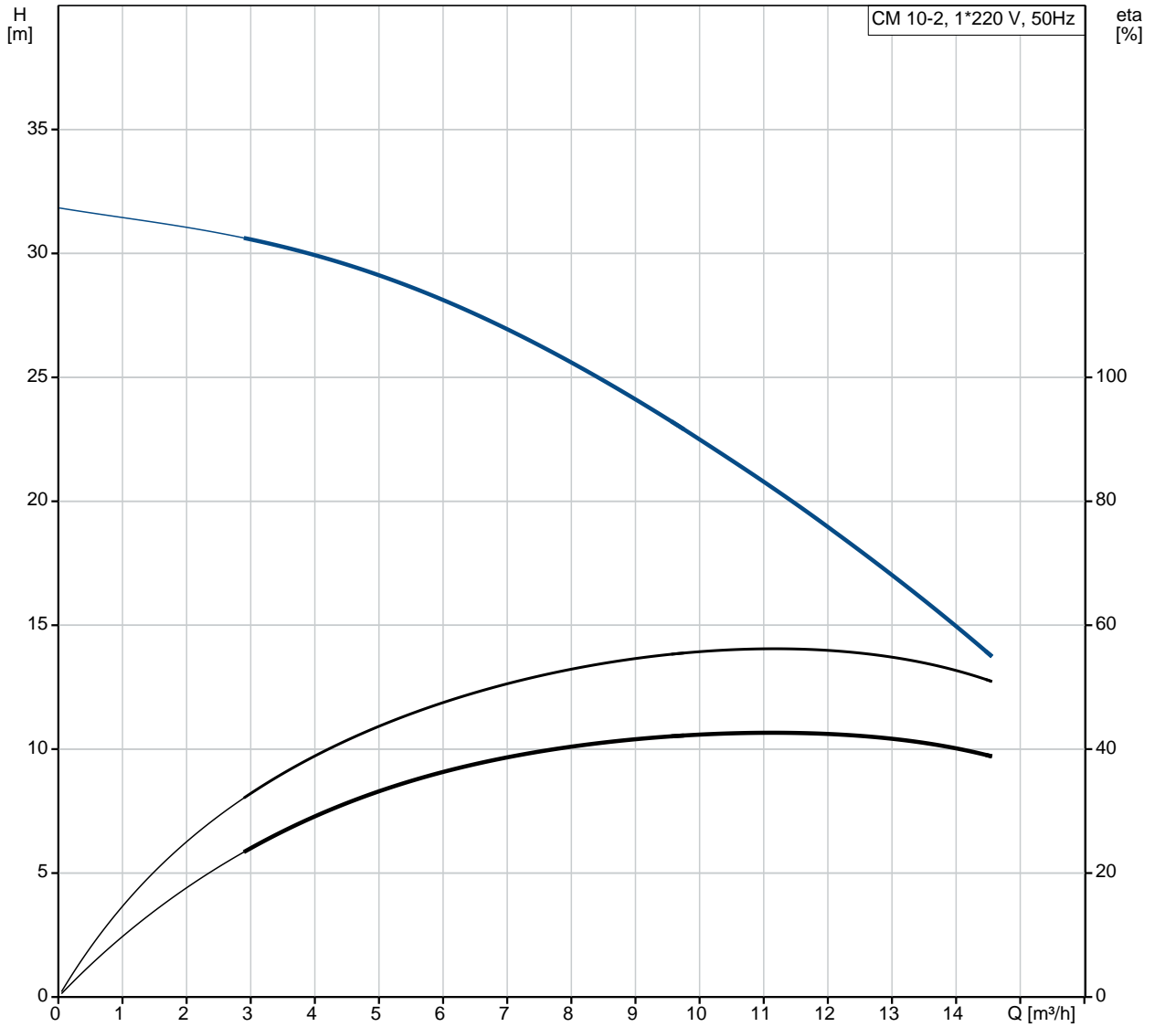

Description	Value
General information:	
Product name:	CM 10-2 A-R-I-E-AQQE C-A-A-N
Product No:	96946004
EAN number:	5700314386443
Price:	5700314386443
	1.003,00 GBP
Technical:	
Pump speed on which pump data are based:	2900 rpm
Rated flow:	10 m ³ /h
Rated head:	24.61 m
Impellers:	2
Code for shaft seal:	AQQE
Curve tolerance:	ISO9906:2012 3B
Pump version:	A
Model:	A
Materials:	
Pump housing:	Stainless steel EN 1.4301 AISI 304
Impeller:	Stainless steel EN 1.4301 AISI 304
Material code:	I
Code for rubber:	E
Installation:	
Range of ambient temperature:	-20 .. 55 °C
Maximum operating pressure:	16 bar
Max pressure at stated temp:	16 bar / 90 °C 10 bar / 120 °C
Type of connection:	Rp
Size of inlet connection:	1 1/2 inch
Size of outlet connection:	1 1/2 inch
Outlet position:	12
Connect code:	R
Liquid:	
Pumped liquid:	Water
Liquid temperature range:	-20 .. 120 °C
Selected liquid temperature:	20 °C
Density at selected liquid temperature:	998.2 kg/m ³
Electrical data:	
Motor standard:	IEC
Frame size:	90A
Rated power - P2:	1.3 kW
Mains frequency:	50 Hz
Phases:	1
Rated voltage:	220-240 V
Service factor:	1.00
Rated current:	8.4-8.0 A
Starting current:	340-340 %
Rated speed:	2710 rpm
Enclosure class (IEC 34-5):	IP55
Insulation class (IEC 85):	F
Built-in motor protection:	PTO
Controls:	
Frequency converter:	NONE
Others:	

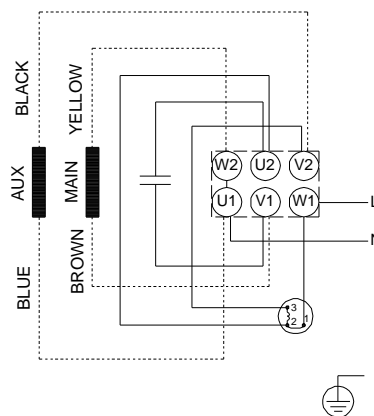
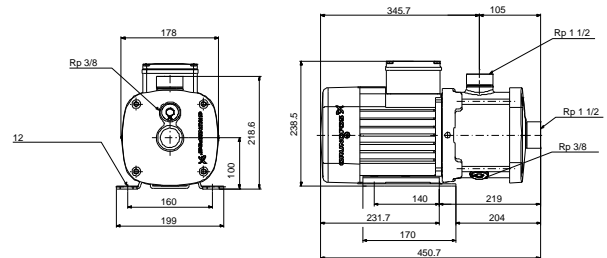
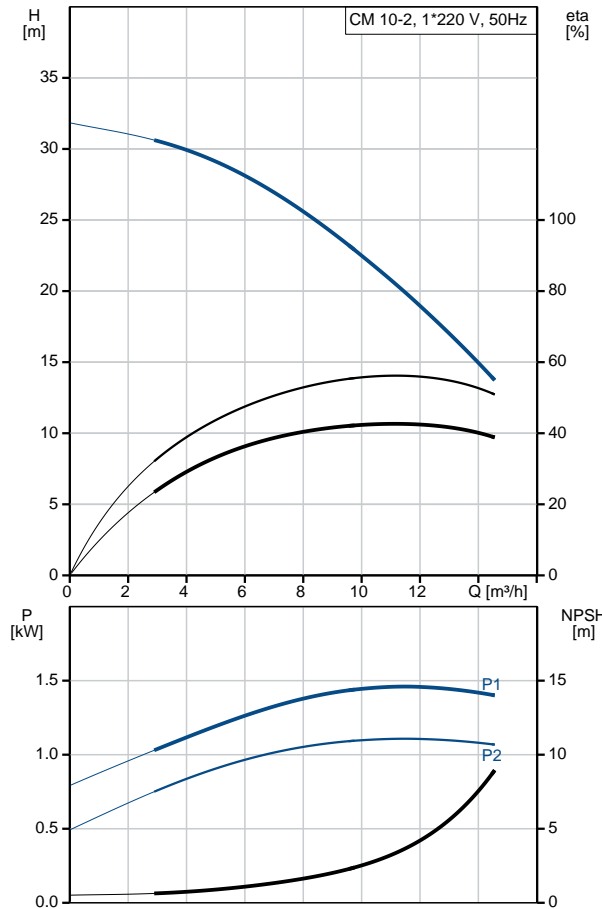



Company name:

Created by:

Phone:

Date:

25/09/2019

Description	Value
Terminal box position:	12
Minimum efficiency index, MEI :	0.52
Net weight:	24.8 kg
Gross weight:	27.3 kg
Approvals:	CE,WRAS,ACS,TR,EAC
Country of origin:	HU
Custom tariff no.:	84137075

96946004 CM 10-2 A-R-I-E-AQQE C-A-A-N 50 Hz

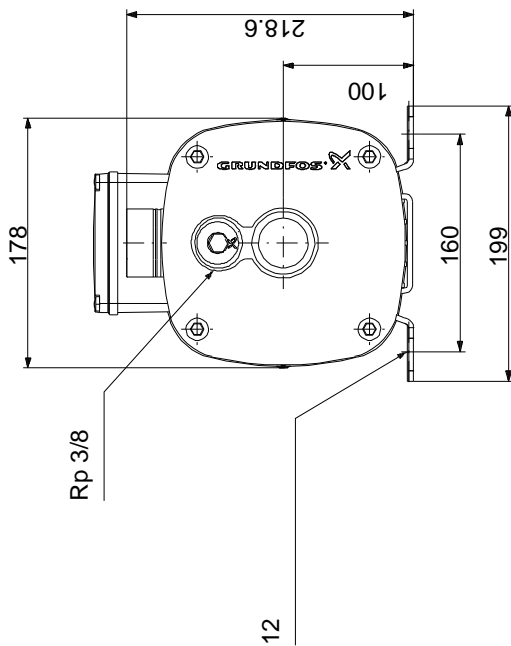
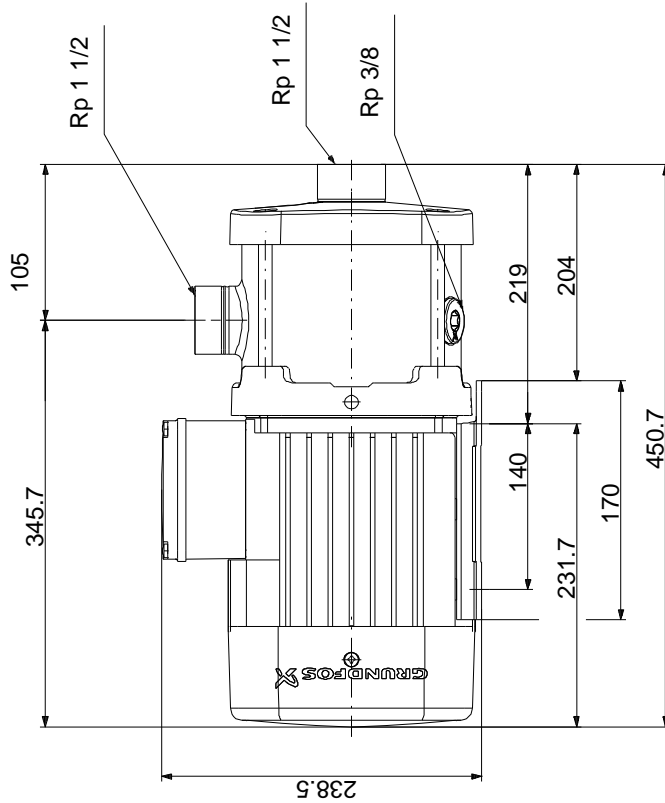

Note! All units are in [mm] unless others are stated.
Disclaimer: This simplified dimensional drawing does not show all details.

96946004 CM 10-2 A-R-I-E-AQQE C-A-A-N 50 Hz

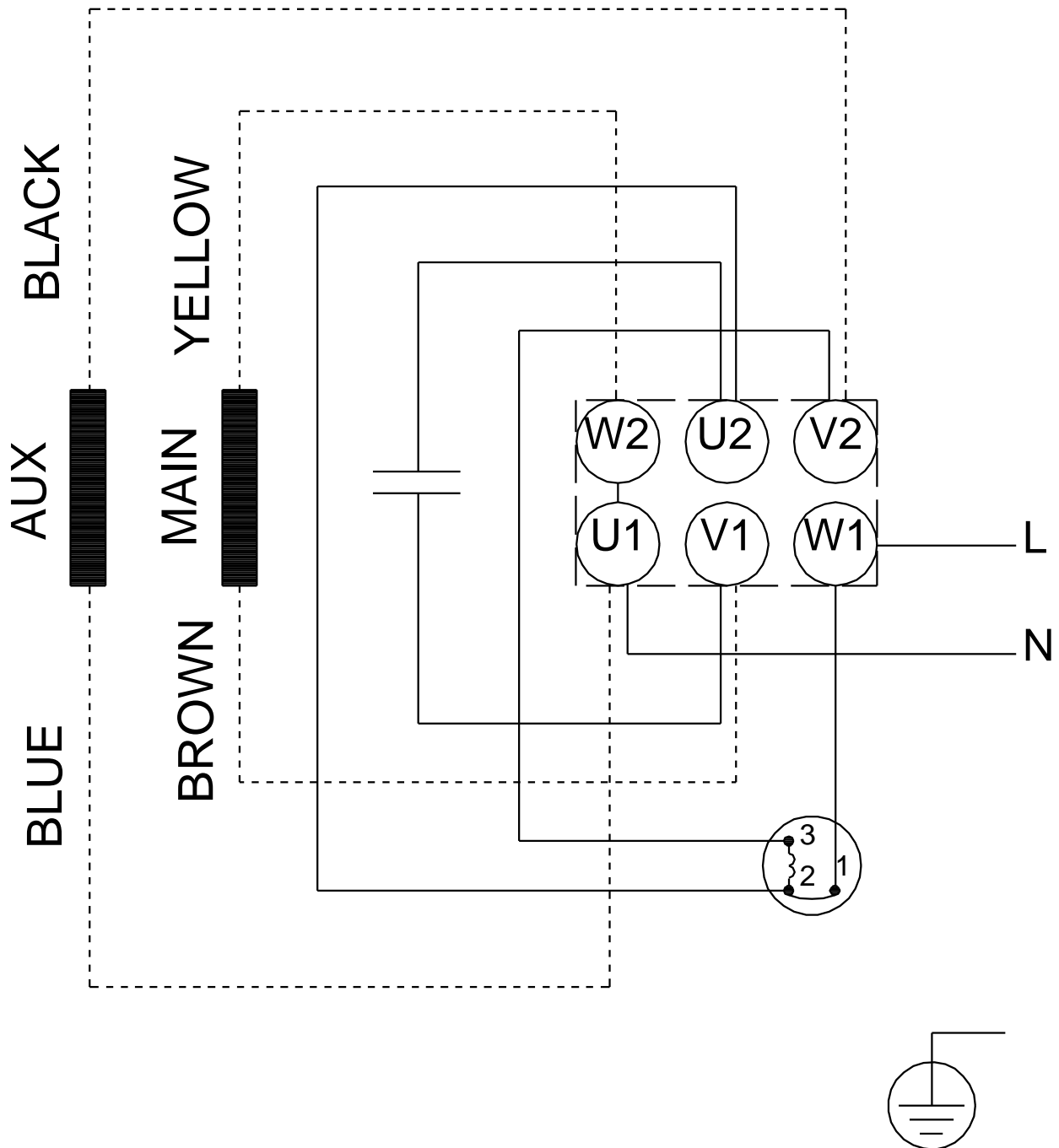

Note! All units are in [mm] unless others are stated.