

Qty. Description

1 **CMBE 1-44 I-U-C-D-D-A**



Note! Product picture may differ from actual product

Product No.: [98374679](#)

The Grundfos CMBE booster is a compact booster system for water supply in domestic applications. The integrated speed controller enables the CMBE booster to keep constant pressure in the pipe system. A pressure sensor monitoring changes in the water consumption signals the speed controller to change motor speed to adapt performance to the new state.

The CMBE booster is very easy to install. When the system has been connected to the pipes, it is all a matter of inserting the plug into a power supply socket, and the system is operational.

The CMBE booster consists of the following:

- CME pump with integrated frequency converter
- Five-way valve
- expansion tank
- pressure gauge

The Grundfos CMBE booster requires no external motor protection.

The MGE motor incorporates thermal protection against slow overloading and blocking (IEC 34.11: TP 211).

The Grundfos CMBE booster is mainly used for domestic and light commercial water supply or booster systems.

NB:

Suction lift: maximum 1 m, including inlet pipe pressure loss at a liquid temperature of 20 °C (not self-priming).

Controls:

Type of connector: No plug

Frequency converter: Built-in

Liquid:

Pumped liquid: Water

Liquid temperature range: 0 .. 60 °C

Selected liquid temperature: 20 °C

Density: 998.2 kg/m³

Technical:

Pump speed on which pump data are based: 3776 rpm

Rated flow: 2.4 m³/h

Rated head: 28.7 m

Code for shaft seal: AVBE

Approvals: CE,EAC,CN ROHS EXE,MORO,UKCA

Approvals for drinking water: WRAS

Curve tolerance: ISO9906:2012 3B

Return valve: YES

Start pressure: Integrated Frequency converter

Tank volume: 2 l

Materials:

Pump housing: Stainless steel

Qty. Description

1	<p>EN 1.4301 AISI 304 Impeller: Stainless steel EN 1.4301 AISI 304</p> <p>Installation: Maximum ambient temperature: 55 °C Maximum operating pressure: 10 bar Pipe connection standard: ISO 228-1 Type of inlet connection: Rp Type of outlet connection: Rp Size of inlet connection: 1 Size of outlet connection: 1 Pressure rating for connection: PN 10</p> <p>Electrical data: Rated power - P2: 0.55 kW Mains frequency: 50 Hz Rated voltage: 1 x 200-240 V Maximum current consumption: 3.45-2.90 A Rated speed: 360-4000 rpm Enclosure class (IEC 34-5): IP55 Insulation class (IEC 85): F Length of cable: 1.5 m Power plug: No plug</p> <p>Others: Net weight: 15.9 kg Gross weight: 26.3 kg Shipping volume: 0.159 m³ Country of origin: HU Custom tariff no.: 84137075 Environmental approvals: WEEE</p>
---	---

Description	Value
General information:	
Product name:	CMBE 1-44 I-U-C-D-D-A
Product No:	98374679
EAN number:	5711493909194
Price:	GBP 2046
Technical:	
Pump speed on which pump data are based:	3776 rpm
Rated flow:	2.4 m³/h
Rated head:	28.7 m
Impellers:	3
Code for shaft seal:	AVBE
Approvals:	CE,EAC,CN ROHS EXE,MORO,UKCA
Approvals for drinking water:	WRAS
Curve tolerance:	ISO9906:2012 3B
Model:	A
Return valve:	YES
Start pressure:	Integrated Frequency converter
Tank volume:	2 l
Materials:	
Pump housing:	Stainless steel
Pump housing:	EN 1.4301
Pump housing:	AISI 304
Impeller:	Stainless steel
Impeller:	EN 1.4301
Impeller:	AISI 304
Code for rubber:	EPDM
Installation:	
Maximum ambient temperature:	55 °C
Maximum operating pressure:	10 bar
Pipe connection standard:	ISO 228-1
Type of inlet connection:	Rp
Type of outlet connection:	Rp
Size of inlet connection:	1
Size of outlet connection:	1
Pressure rating for connection:	PN 10
Liquid:	
Pumped liquid:	Water
Liquid temperature range:	0 .. 60 °C
Selected liquid temperature:	20 °C
Density:	998.2 kg/m³
Electrical data:	
Rated power - P2:	0.55 kW
Mains frequency:	50 Hz
Rated voltage:	1 x 200-240 V
Maximum current consumption:	3.45-2.90 A
Rated speed:	360-4000 rpm
Enclosure class (IEC 34-5):	IP55
Insulation class (IEC 85):	F
Length of cable:	1.5 m
Power plug:	No plug
Controls:	
Type of connector:	No plug
Frequency converter:	Built-in
Others:	
Net weight:	15.9 kg
Gross weight:	26.3 kg

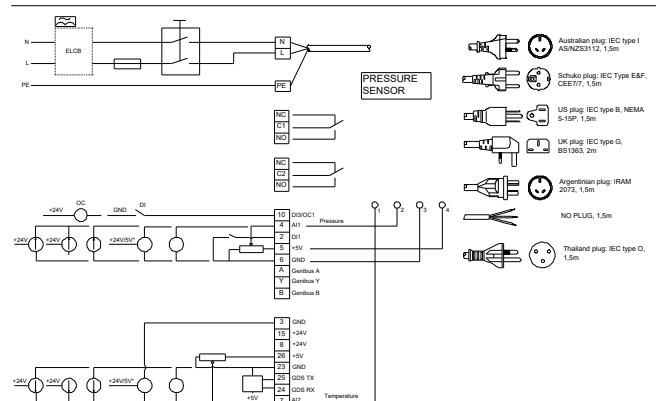
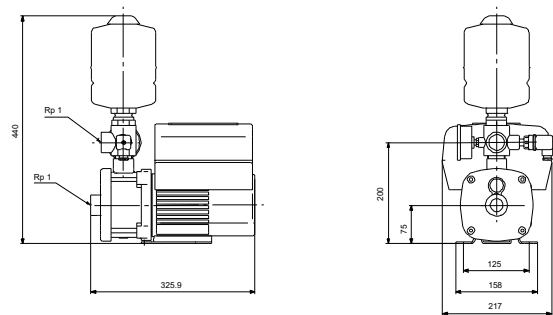
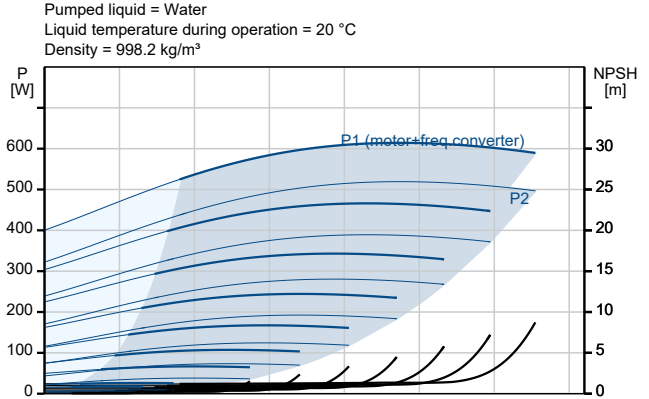
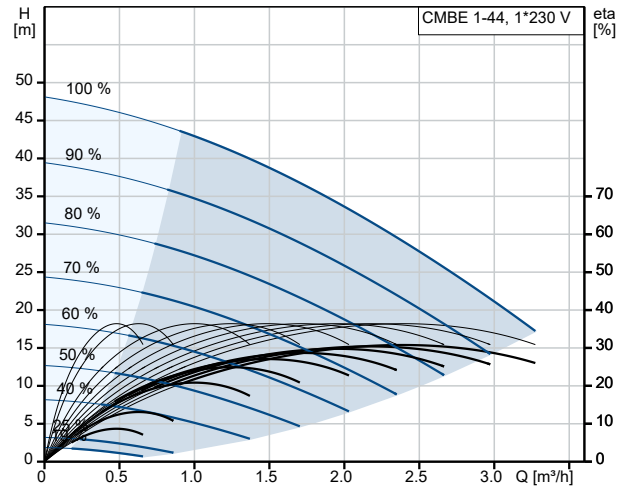



Company name:

Created by:

Phone:

Date:

09/04/2024

Description	Value
Shipping volume:	0.159 m ³
Config. file no:	98390431
Country of origin:	HU
Custom tariff no.:	84137075
Environmental approvals:	WEEE