



Position	Qty.	Description																																
	1	<p><b>CRI 1-9 A-CA-I-V-HQQV</b></p>  <p style="text-align: right;"><b>Note! Product picture may differ from actual product</b></p> <p>Product No.: <a href="#">96532171</a>                      Vertical, non-self-priming, multistage, in-line, centrifugal pump for installation in pipe systems and mounting on a foundation.</p> <p>The pump has the following characteristics:</p> <ul style="list-style-type: none"> <li>- Impellers, intermediate chambers and outer sleeve are made of Stainless steel, DIN W.-Nr. 1.4301.</li> <li>- Pump head cover and base are made of Stainless steel, DIN W.-Nr. 1.4408.</li> <li>- The shaft seal has assembly length according to EN 12756.</li> <li>- Power transmission is via cast iron split coupling.</li> <li>- Pipework connection is via CLAMP flanges/couplings.</li> </ul> <p>The motor is a 1-phase AC motor.</p> <p><b>Liquid:</b></p> <table border="0"> <tr><td>Pumped liquid:</td><td>Water</td></tr> <tr><td>Liquid temperature range:</td><td>-20 .. 90 °C</td></tr> <tr><td>Liquid temp:</td><td>20 °C</td></tr> <tr><td>Density:</td><td>998.2 kg/m<sup>3</sup></td></tr> <tr><td>Kinematic viscosity:</td><td>1 mm<sup>2</sup>/s</td></tr> </table> <p><b>Technical:</b></p> <table border="0"> <tr><td>Speed for pump data:</td><td>2750 rpm</td></tr> <tr><td>Rated flow:</td><td>1.8 m<sup>3</sup>/h</td></tr> <tr><td>Rated head:</td><td>40.7 m</td></tr> <tr><td>Shaft seal:</td><td>HQQV</td></tr> <tr><td>Approvals on nameplate:</td><td>CE</td></tr> </table> <p><b>Materials:</b></p> <table border="0"> <tr><td>Pump housing:</td><td>Stainless steel</td></tr> <tr><td>Pump housing:</td><td>DIN W.-Nr. 1.4408</td></tr> <tr><td>Pump housing:</td><td>ASTM A 351 CF 8M</td></tr> <tr><td>Impeller:</td><td>Stainless steel</td></tr> <tr><td>Impeller:</td><td>DIN W.-Nr. 1.4301</td></tr> <tr><td>Impeller:</td><td>AISI 304</td></tr> </table> <p><b>Installation:</b></p> <p>Maximum ambient temperature: 40 °C</p>	Pumped liquid:	Water	Liquid temperature range:	-20 .. 90 °C	Liquid temp:	20 °C	Density:	998.2 kg/m <sup>3</sup>	Kinematic viscosity:	1 mm <sup>2</sup> /s	Speed for pump data:	2750 rpm	Rated flow:	1.8 m <sup>3</sup> /h	Rated head:	40.7 m	Shaft seal:	HQQV	Approvals on nameplate:	CE	Pump housing:	Stainless steel	Pump housing:	DIN W.-Nr. 1.4408	Pump housing:	ASTM A 351 CF 8M	Impeller:	Stainless steel	Impeller:	DIN W.-Nr. 1.4301	Impeller:	AISI 304
Pumped liquid:	Water																																	
Liquid temperature range:	-20 .. 90 °C																																	
Liquid temp:	20 °C																																	
Density:	998.2 kg/m <sup>3</sup>																																	
Kinematic viscosity:	1 mm <sup>2</sup> /s																																	
Speed for pump data:	2750 rpm																																	
Rated flow:	1.8 m <sup>3</sup> /h																																	
Rated head:	40.7 m																																	
Shaft seal:	HQQV																																	
Approvals on nameplate:	CE																																	
Pump housing:	Stainless steel																																	
Pump housing:	DIN W.-Nr. 1.4408																																	
Pump housing:	ASTM A 351 CF 8M																																	
Impeller:	Stainless steel																																	
Impeller:	DIN W.-Nr. 1.4301																																	
Impeller:	AISI 304																																	



Position	Qty.	Description
		Max pressure at stated temp: 25 bar / 90 °C Max pressure at stated temp: 25 bar / -20 °C Flange standard: CLAMP Pipe connection: 59 mm Flange size for motor: FT100  <b>Electrical data:</b> Motor type: 80A IE Efficiency class: NA Number of poles: 2 Rated power - P2: 0.55 kW Power (P2) required by pump: 0.55 kW Mains frequency: 50 Hz Rated voltage: 1 x 220-230/240 V Rated current: 4,00/3,65 A Starting current: 280 % Cos phi - power factor: 0,99 Rated speed: 2750 rpm Motor efficiency at full load: 66-64 % Enclosure class (IEC 34-5): 55 (Protect. water jets/dust) Insulation class (IEC 85): F  <b>Others:</b> Net weight: 22.2 kg Gross weight: 24.9 kg Shipping volume: 0.05 m3



## 96532171 CRI 1-9 50 Hz

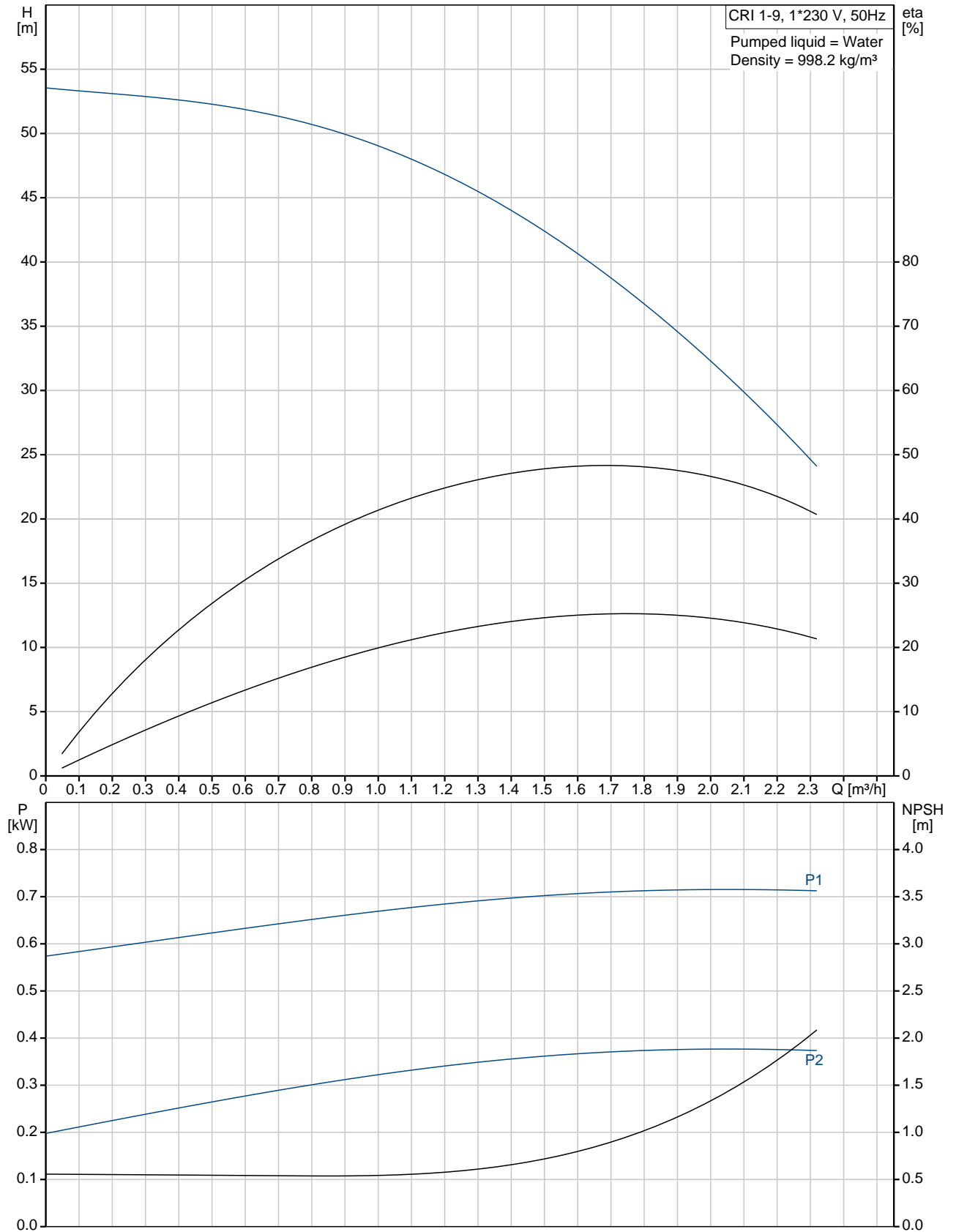

Description	Value
Product name:	CRI 1-9 A-CA-I-V-HQQV
Product No:	96532171
EAN number:	5700397367636
<b>Technical:</b>	
Speed for pump data:	2750 rpm
Rated flow:	1.8 m³/h
Rated head:	40.7 m
Impellers:	9
Shaft seal:	HQQV
Approvals on nameplate:	CE
Stages:	9
Pump version:	A
Model:	A
<b>Materials:</b>	
Pump housing:	Stainless steel DIN W.-Nr. 1.4408
Impeller:	ASTM A 351 CF 8M Stainless steel DIN W.-Nr. 1.4301 AISI 304
Material code:	I
Code for rubber:	V
<b>Installation:</b>	
Maximum ambient temperature:	40 °C
Max pressure at stated temp:	25 bar / 90 °C 25 bar / -20 °C
Flange standard:	CLAMP
Connect code:	CA
Pipe connection:	59 mm
Flange size for motor:	FT100
<b>Liquid:</b>	
Pumped liquid:	Water
Liquid temperature range:	-20 .. 90 °C
Liquid temp:	20 °C
Density:	998.2 kg/m³
Kinematic viscosity:	1 mm²/s
<b>Electrical data:</b>	
Motor type:	80A
IE Efficiency class:	NA
Number of poles:	2
Rated power - P2:	0.55 kW
Power (P2) required by pump:	0.55 kW
Mains frequency:	50 Hz
Rated voltage:	1 x 220-230/240 V
Rated current:	4,00/3,65 A
Starting current:	280 %
Cos phi - power factor:	0,99
Rated speed:	2750 rpm
Motor efficiency at full load:	66-64 %
Enclosure class (IEC 34-5):	55 (Protect. water jets/dust)
Insulation class (IEC 85):	F
Motor protec:	PTO
Motor No:	85215103
<b>Others:</b>	
Net weight:	22.2 kg
Gross weight:	24.9 kg
Shipping volume:	0.05 m3
Sales region:	GB

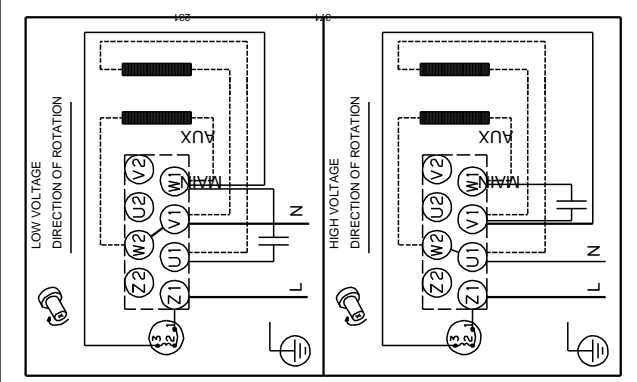
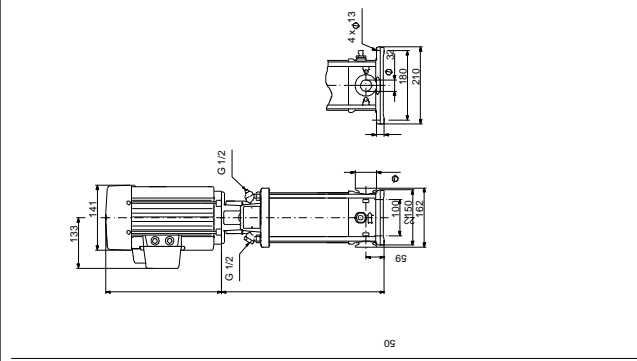
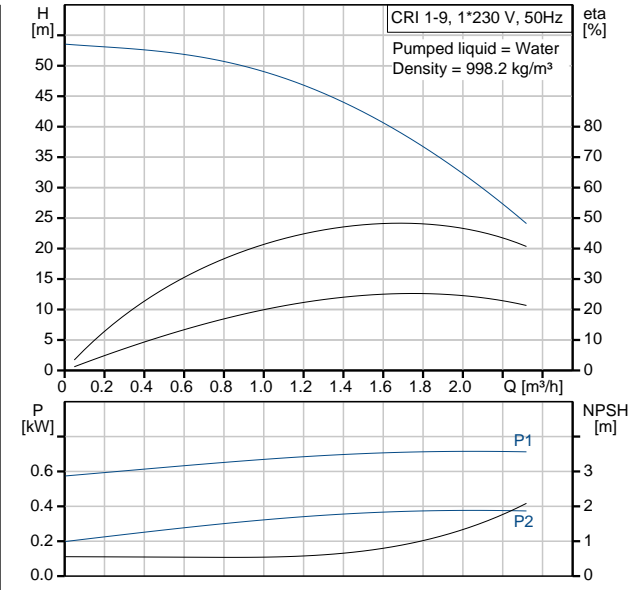



Company name: -  
Created by: -  
Phone: -  
Fax: -  
Date: -

Description	Value
-------------	-------



96532171 CRI 1-9 50 Hz

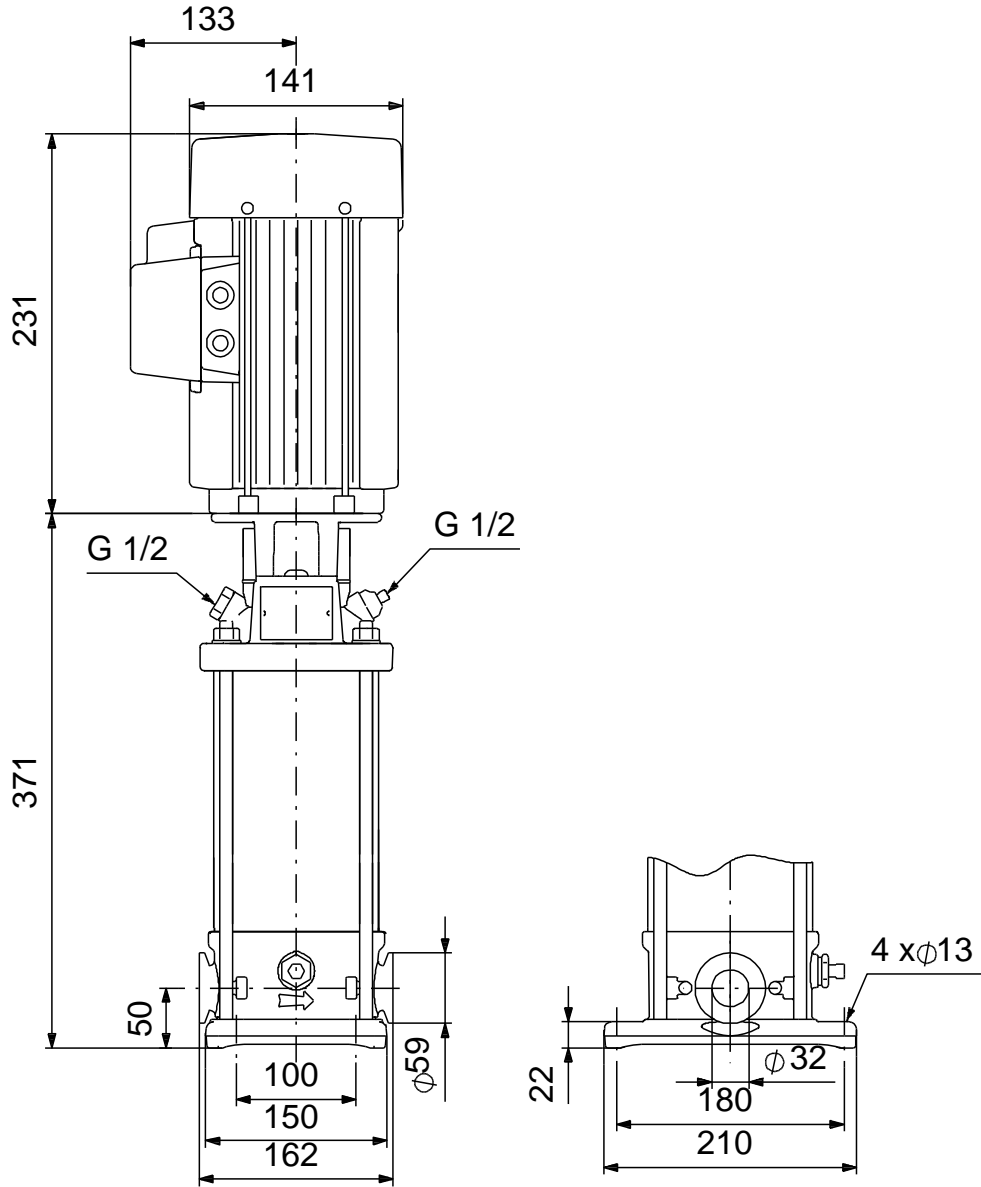

Note! All units are in [mm] unless others are stated.  
Disclaimer: This simplified dimensional drawing does not show all details.