



Position	Qty.	Description
----------	------	-------------

1 CRI 3-9 A-CA-I-V-HQQV



Note! Product picture may differ from actual product

Product No.: [96533217](#)

Vertical, non-self-priming, multistage, in-line, centrifugal pump for installation in pipe systems and mounting on a foundation.

The pump has the following characteristics:

- Impellers, intermediate chambers and outer sleeve are made of Stainless steel, DIN W.-Nr. 1.4301.
- Pump head cover and base are made of Stainless steel, DIN W.-Nr. 1.4408.
- The shaft seal has assembly length according to EN 12756.
- Power transmission is via cast iron split coupling.
- Pipework connection is via CLAMP flanges/couplings.

The motor is a 1-phase AC motor.

**Liquid:**

Pumped liquid:	Water
Liquid temperature range:	-20 .. 90 °C
Liquid temp:	20 °C
Density:	998.2 kg/m <sup>3</sup>
Kinematic viscosity:	1 mm <sup>2</sup> /s

**Technical:**

Speed for pump data:	2759 rpm
Rated flow:	3 m <sup>3</sup> /h
Rated head:	40 m
Shaft seal:	HQQV
Approvals on nameplate:	CE

**Materials:**

Pump housing:	Stainless steel
Pump housing:	DIN W.-Nr. 1.4408
Pump housing:	ASTM A 351 CF 8M
Impeller:	Stainless steel
Impeller:	DIN W.-Nr. 1.4301
Impeller:	AISI 304

**Installation:**

Maximum ambient temperature: 40 °C



Position	Qty.	Description
		Max pressure at stated temp: 25 bar / 90 °C Max pressure at stated temp: 25 bar / -20 °C Flange standard: CLAMP Pipe connection: 59 mm Flange size for motor: FT100  <b>Electrical data:</b> Motor type: 80B IE Efficiency class: NA Number of poles: 2 Rated power - P2: 0.75 kW Power (P2) required by pump: 0.75 kW Mains frequency: 50 Hz Rated voltage: 1 x 220-230/240 V Rated current: 5,10/4,75 A Starting current: 300 % Cos phi - power factor: 0,99 Rated speed: 2780 rpm Motor efficiency at full load: 69-67 % Enclosure class (IEC 34-5): 55 (Protect. water jets/dust) Insulation class (IEC 85): F  <b>Others:</b> Net weight: 23.7 kg Gross weight: 26.4 kg Shipping volume: 0.05 m3



**96533217 CRI 3-9 50 Hz**

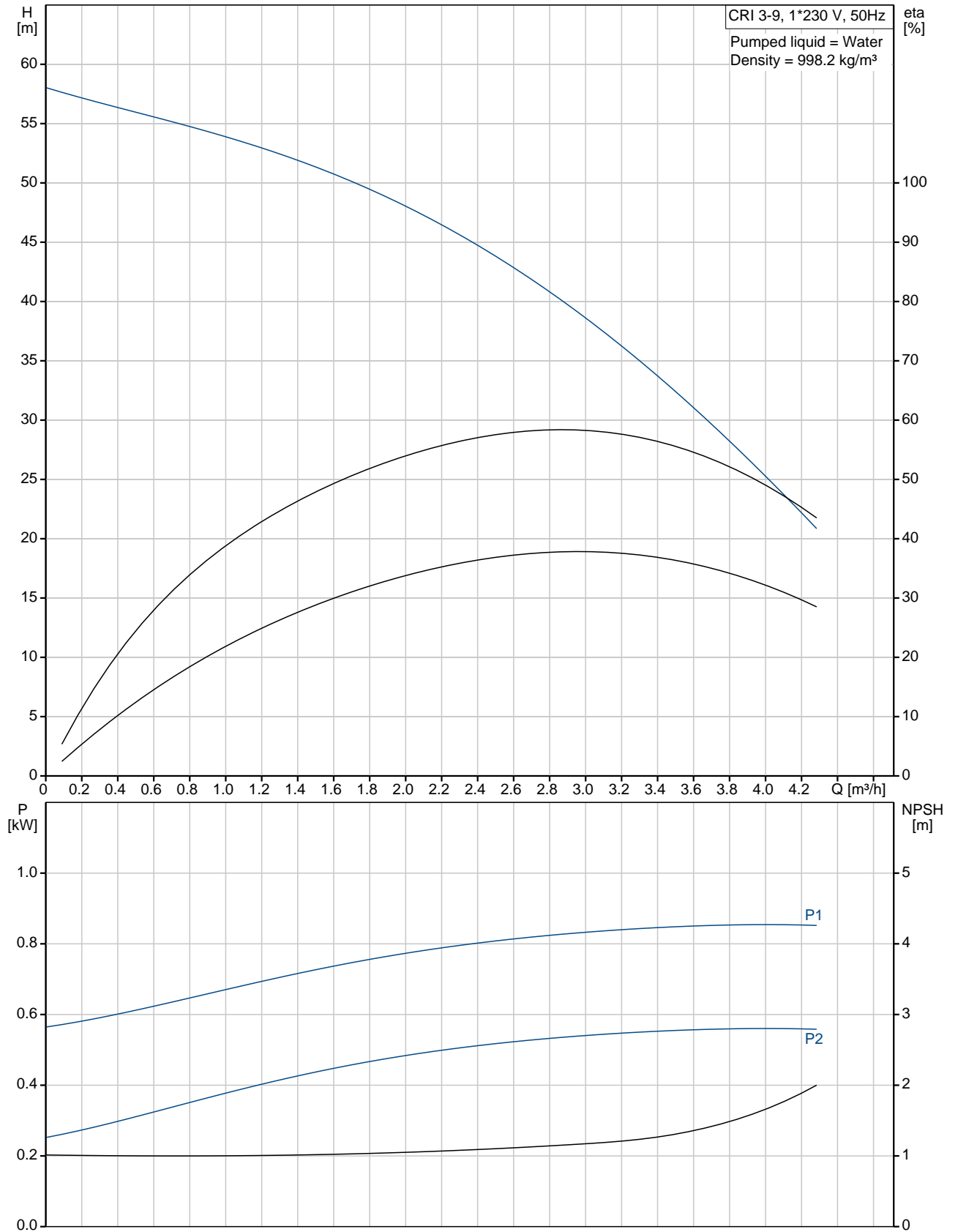

Description	Value
Product name:	CRI 3-9 A-CA-I-V-HQQV
Product No:	96533217
EAN number:	5700397434635
<b>Technical:</b>	
Speed for pump data:	2759 rpm
Rated flow:	3 m³/h
Rated head:	40 m
Impellers:	9
Shaft seal:	HQQV
Approvals on nameplate:	CE
Stages:	9
Pump version:	A
Model:	A
<b>Materials:</b>	
Pump housing:	Stainless steel DIN W.-Nr. 1.4408
Impeller:	Stainless steel ASTM A 351 CF 8M DIN W.-Nr. 1.4301 AISI 304
Material code:	I
Code for rubber:	V
<b>Installation:</b>	
Maximum ambient temperature:	40 °C
Max pressure at stated temp:	25 bar / 90 °C 25 bar / -20 °C
Flange standard:	CLAMP
Connect code:	CA
Pipe connection:	59 mm
Flange size for motor:	FT100
<b>Liquid:</b>	
Pumped liquid:	Water
Liquid temperature range:	-20 .. 90 °C
Liquid temp:	20 °C
Density:	998.2 kg/m³
Kinematic viscosity:	1 mm²/s
<b>Electrical data:</b>	
Motor type:	80B
IE Efficiency class:	NA
Number of poles:	2
Rated power - P2:	0.75 kW
Power (P2) required by pump:	0.75 kW
Mains frequency:	50 Hz
Rated voltage:	1 x 220-230/240 V
Rated current:	5,10/4,75 A
Starting current:	300 %
Cos phi - power factor:	0,99
Rated speed:	2780 rpm
Motor efficiency at full load:	69-67 %
Enclosure class (IEC 34-5):	55 (Protect. water jets/dust)
Insulation class (IEC 85):	F
Motor protec:	PTO
Motor No:	85215104
<b>Others:</b>	
Net weight:	23.7 kg
Gross weight:	26.4 kg
Shipping volume:	0.05 m3
Sales region:	GB

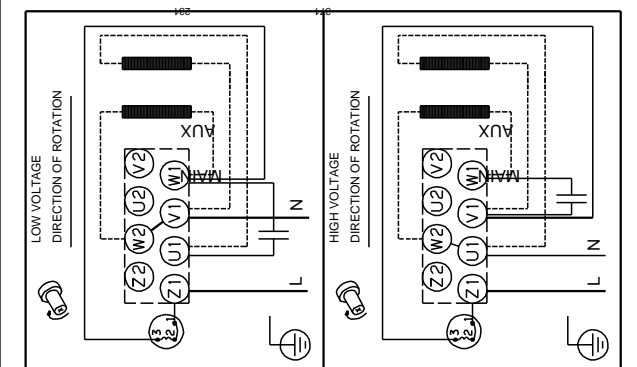
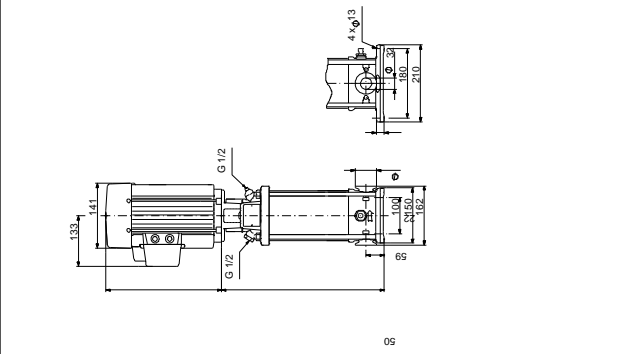
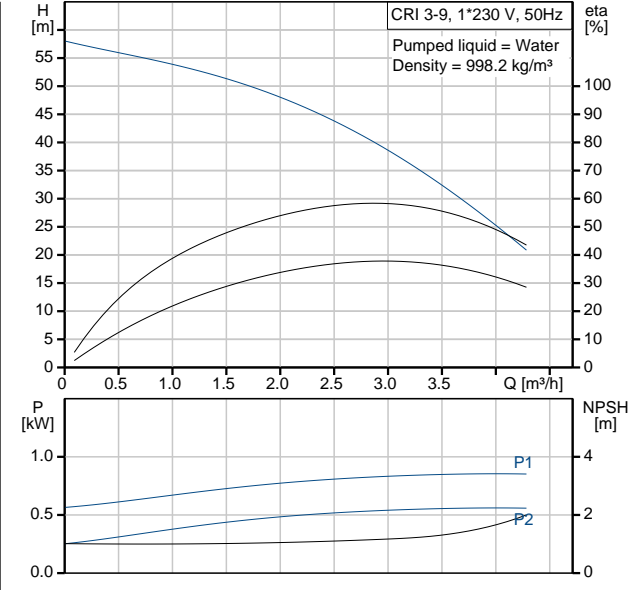



Company name: -  
Created by: -  
Phone: -  
Fax: -  
Date: -

Description	Value
-------------	-------



96533217 CRI 3-9 50 Hz

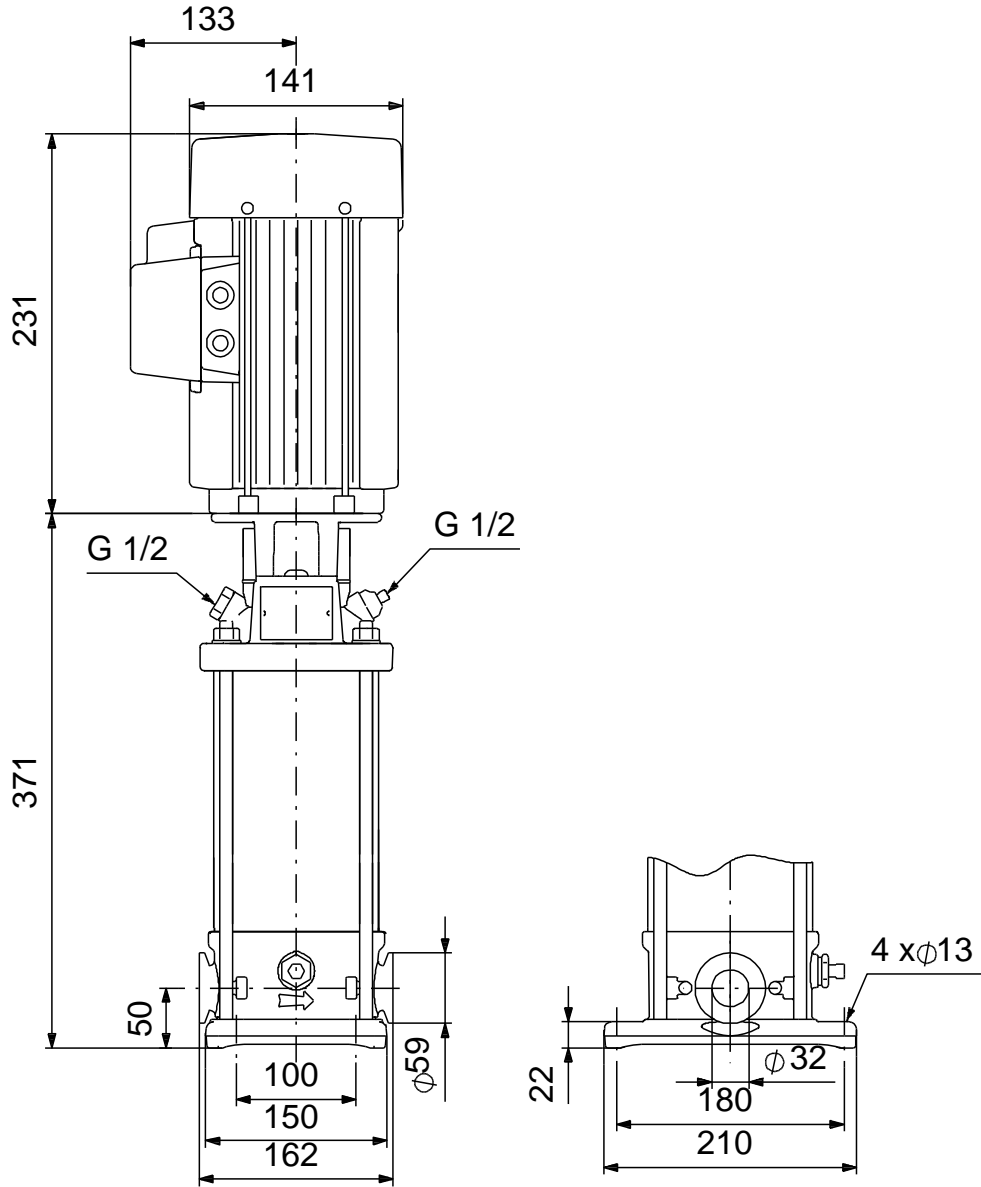

Note! All units are in [mm] unless others are stated.  
Disclaimer: This simplified dimensional drawing does not show all details.