

Qty.	Description
1	<p data-bbox="199 338 686 369"><b>Product name:</b> SB 3-45 A</p> <div data-bbox="240 389 545 1142">  </div> <p data-bbox="592 1182 1075 1209"><b>Note! Product picture may differ from actual product</b></p> <p data-bbox="199 1216 481 1243">Product No.: On request</p> <p data-bbox="564 1305 1426 1429">Grundfos SB 3-45 A is a submersible pump designed for the pumping of clean water for domestic and rainwater applications. It is silent when submerged and therefore a noiseless alternative to surface-mounted pumps. The pump is built from high quality composite and stainless steel materials that are resistant to corrosion.</p> <p data-bbox="199 1473 1453 1552"><b>Max liquid temp:</b> The SB 3-45 A is equipped with a 15 m supply cable, and the maximum installation depth is 10 m below the water level, with a liquid temperature ranging from 0 °C to 40 °C °C.</p> <p data-bbox="199 1592 1465 1644"><b>Product name:</b> The SB 3-45 A is ideal for operation in a well or ground tanks, as it easily prevents solid particles from entering the pump. The maximum particle size is 1 mm.</p> <p data-bbox="199 1706 1401 1785"><b>Flow switch:</b> The pump features a float switch, which promises the user a convenient experience with automatic start/stop operation of the pump and provides dry running protection.</p> <p data-bbox="199 1850 1398 1877">The single-phase model is effectively protected against any accidental overload by built-in thermal protection.</p> <p data-bbox="199 1912 1437 1964">The pump has built-in thermal protection, which immediately stops the pump if it overheats. Having cooled down, the pump automatically restarts when it reaches a normal temperature.</p> <p data-bbox="199 2029 635 2085"><b>Liquid:</b> <b>Pumped liquid:</b> Water</p>

Qty.	Description
	Liquid temperature range: 0 .. 40 °C °C Selected liquid temperature: 20 °C Density: 998.2 kg/m <sup>3</sup>  Technical: Rated flow: 2.83 m <sup>3</sup> /h Rated head: 30.1 m Max. Particle: 1 mm Approvals: CE,WEEE Curve tolerance: ISO9906:2012 3B Return valve: NO Rated driver speed: 2800 rpm  Materials: Pump housing: Composite Impeller: Composite  Installation: Range of ambient temperature: -10 .. 50 °C Type of inlet connection: STRAINER Pump outlet: G 1" Maximum installation depth: 10 m  Electrical data: Power input P1: 1.05 kW Rated power - P2: 0.62 kW Mains frequency: 50 Hz Rated voltage: 1 x 220-240 V Rated current: 4.8 A Starting current: 12 A Cos phi: 0.94 Capacitor size - run: 13 µF/450 V Enclosure class (IEC 34-5): IP68 Insulation class (IEC 85): F Built-in motor protection: YES Length of cable: 15 m Cable type: H07RN-F 3G1 Type of cable plug: SCHUKO  Others: Net weight: 9.69 kg Gross weight: 10.4 kg Shipping volume: 0.022 m <sup>3</sup> Danish VVS No.: 391361045 Swedish RSK No.: 5850350 Finnish LVI No.: 4822540 Norwegian NRF no.: 9041868

## On request SB 3-45 A 50 Hz

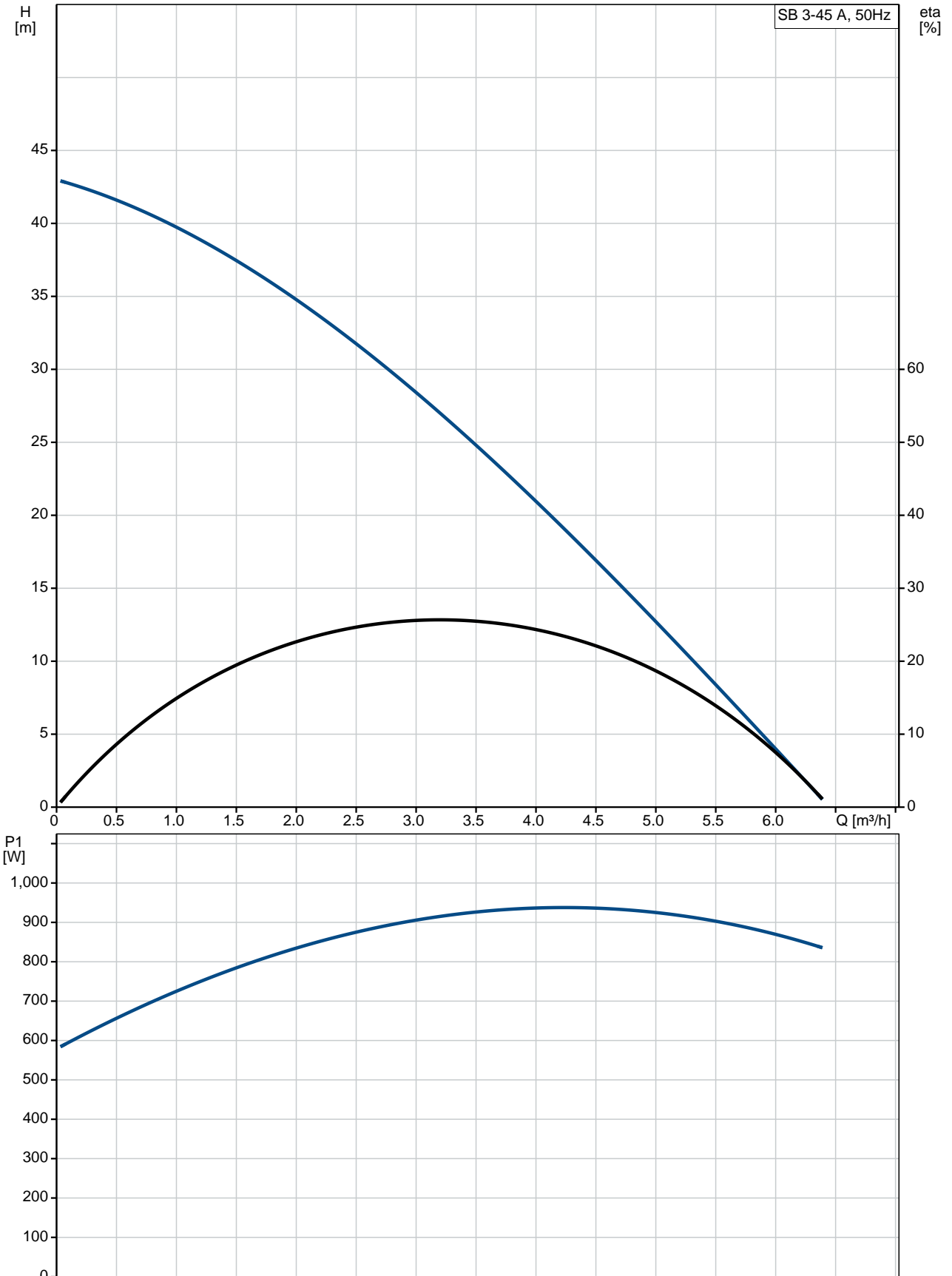

Description	Value
<b>General information:</b>	
Product name:	SB 3-45 A
Product No:	On request
EAN number:	On request
Price:	
<b>Technical:</b>	
Rated flow:	2.83 m <sup>3</sup> /h
Rated head:	30.1 m
Maximum head:	45 m
Impellers:	4
Max. Particle:	1 mm
Approvals:	CE, WEEE
Curve tolerance:	ISO9906:2012 3B
Return valve:	NO
Rated driver speed:	2800 rpm
<b>Materials:</b>	
Pump housing:	Composite
Impeller:	Composite
<b>Installation:</b>	
Range of ambient temperature:	-10 .. 50 °C
Type of inlet connection:	STRAINER
Pump outlet:	G 1"
Maximum installation depth:	10 m
<b>Liquid:</b>	
Pumped liquid:	Water
Liquid temperature range:	0 .. 40 °C °C
Selected liquid temperature:	20 °C
Density:	998.2 kg/m <sup>3</sup>
pH-value range:	4-9
<b>Electrical data:</b>	
Power input P1:	1.05 kW
Rated power - P2:	0.62 kW
Mains frequency:	50 Hz
Rated voltage:	1 x 220-240 V
Rated current:	4.8 A
Starting current:	12 A
Cos phi:	0.94
Capacitor size - run:	13 µF/450 V
Enclosure class (IEC 34-5):	IP68
Insulation class (IEC 85):	F
Built-in motor protection:	YES
Length of cable:	15 m
Cable type:	H07RN-F 3G1
Type of cable plug:	SCHUKO
<b>Controls:</b>	
Flow switch:	yes
<b>Others:</b>	
Net weight:	9.69 kg
Gross weight:	10.4 kg
Shipping volume:	0.022 m <sup>3</sup>
Danish VVS No.:	391361045
Swedish RSK No.:	5850350
Finnish LVI No.:	4822540
Norwegian NRF no.:	9041868

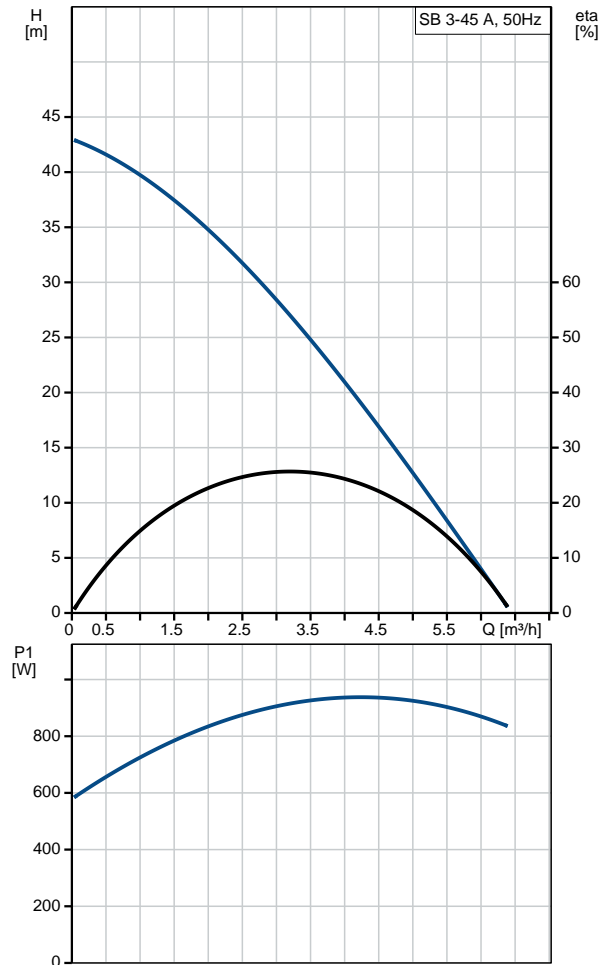

**On request SB 3-45 A 50 Hz**

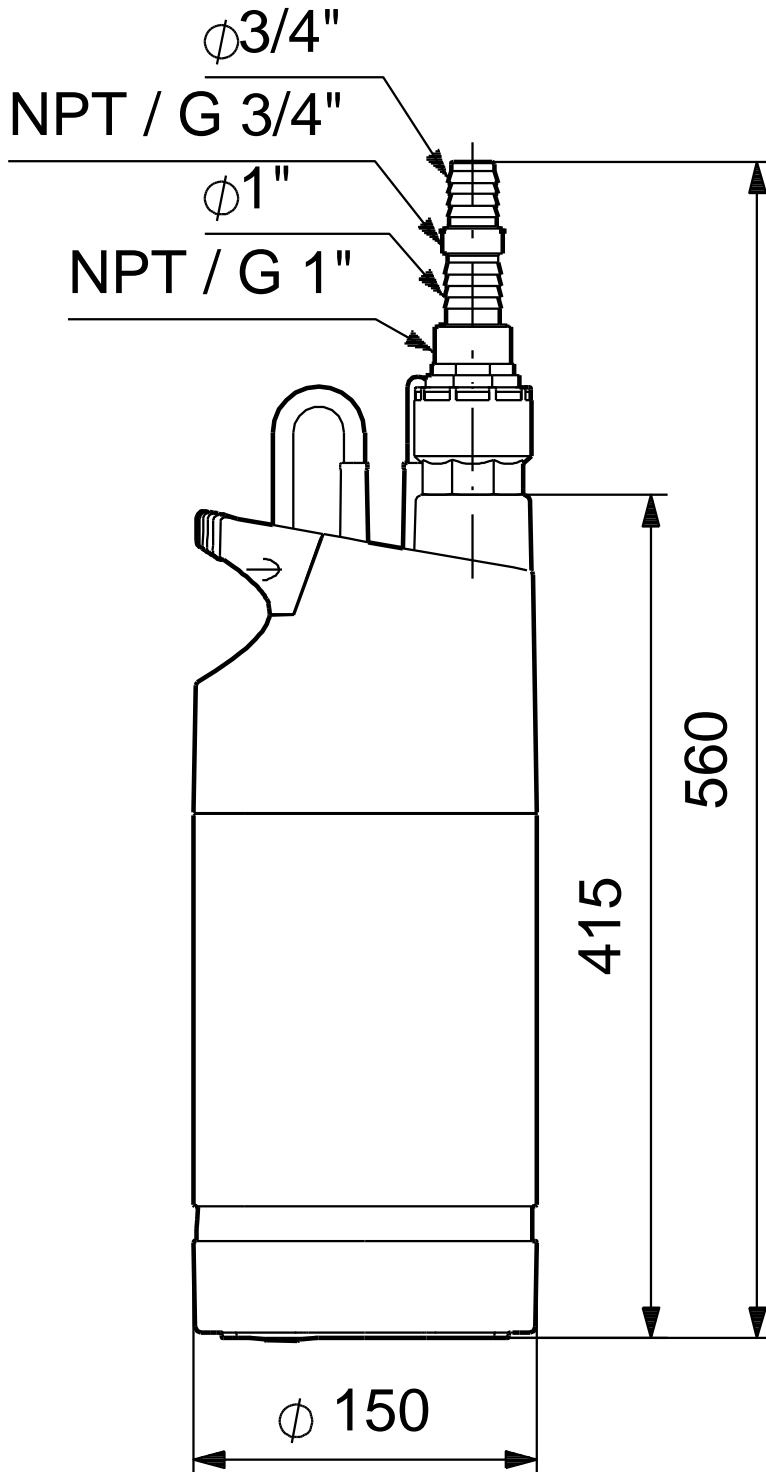

Note! All units are in [mm] unless others are stated.  
Disclaimer: This simplified dimensional drawing does not show all details.