

Qty. Description

1 **Product name:** SBA 3-35 A



Note! Product picture may differ from actual product

Product No.: On request

Grundfos SBA 3-35 A is an all-in-one submersible booster designed for pumping clean water for domestic use. The SBA is built on the proven SB platform and comes with an integrated control unit. This eliminates the need for an external pump controller in the house. It is silent when submerged and therefore a noiseless alternative to surface-mounted pumps. The pump is built from high quality composite and stainless steel materials that are resistant to corrosion.

Max liquid temp:

The SBA 3-35 A is equipped with a 15 m supply cable, and the maximum installation depth is 10 m below the water level, with a liquid temperature ranging from 0 °C to 40 °C.

The pump starts automatically when the pipe pressure falls below 2.2 bar.

Product name:

The SBA 3-35 A is ideal for operation in a well or ground tanks, as it easily prevents solid particles from entering the pump. The maximum particle size is 1 mm.

Qty.	Description
	<p>Flow switch: The pump features a float switch, which promises the user a convenient experience with automatic start/stop operation of the pump and provides dry running protection.</p> <p>The single-phase model is effectively protected against any accidental overload by built-in thermal protection.</p> <p>The pump has built-in thermal protection, which immediately stops the pump if it overheats. Having cooled down, the pump automatically restarts when it reaches a normal temperature.</p> <p>Liquid:</p> <p>Pumped liquid: Water</p> <p>Liquid temperature range: 0 .. 40 °C</p> <p>Selected liquid temperature: 20 °C</p> <p>Density: 998.2 kg/m³</p> <p>Technical:</p> <p>Rated flow: 2.76 m³/h</p> <p>Rated head: 25.2 m</p> <p>Max. Particle: 1 mm</p> <p>Approvals: CE, VDE, WEEE</p> <p>Curve tolerance: ISO9906:2012 3B</p> <p>Return valve: YES</p> <p>Adjustable start pressure: N</p> <p>Start pressure: 1.5 bar</p> <p>Rated driver speed: 2800 rpm</p> <p>Materials:</p> <p>Pump housing: Composite</p> <p>Impeller: Composite</p> <p>Installation:</p> <p>Range of ambient temperature: -10 .. 50 °C</p> <p>Type of inlet connection: STRAINER</p> <p>Pump outlet: G 1"</p> <p>Maximum installation depth: 10 m</p> <p>Electrical data:</p> <p>Power input P1: 0.8 kW</p> <p>Rated power - P2: 0.54 kW</p> <p>Mains frequency: 50 Hz</p> <p>Rated voltage: 1 x 220-240 V</p> <p>Rated current: 3.8 A</p> <p>Starting current: 12 A</p> <p>Cos phi: 0.94</p> <p>Capacitor size - run: 13 µF/450 V</p> <p>Enclosure class (IEC 34-5): IP68</p> <p>Insulation class (IEC 85): F</p> <p>Built-in motor protection: YES</p> <p>Length of cable: 15 m</p> <p>Cable type: H07RN-F 3G1</p> <p>Type of cable plug: SCHUKO</p> <p>Others:</p> <p>Net weight: 9.42 kg</p> <p>Gross weight: 10 kg</p> <p>Shipping volume: 0.022 m³</p>



Company name:

Created by:

Phone:

Date:

19/01/2021

Qty.	Description
------	-------------

	Danish VVS No.: 391367035
	Swedish RSK No.: 5850417
	Finnish LVI No.: 4822596
	Norwegian NRF no.: 9041873

On request SBA 3-35 A 50 Hz

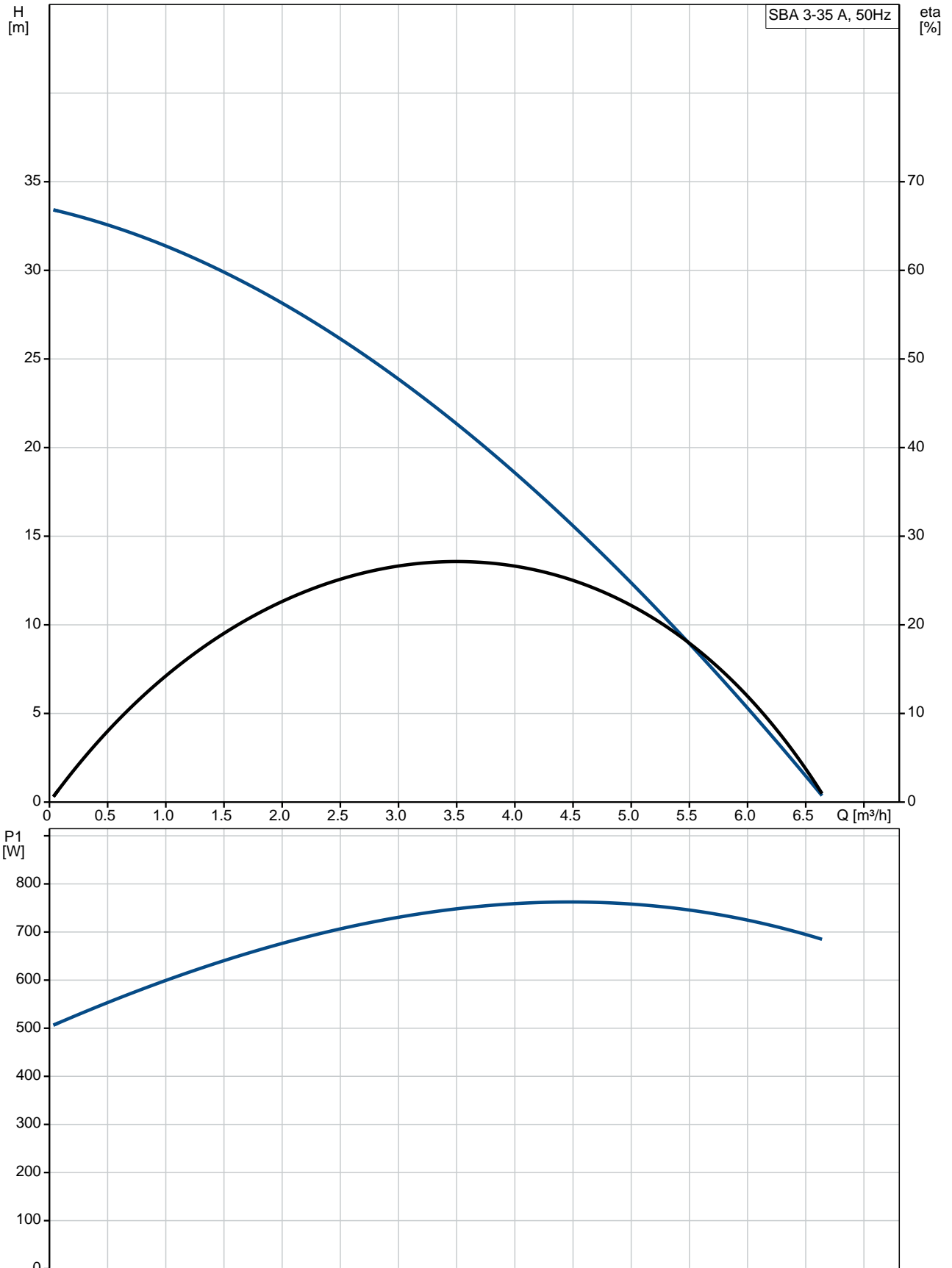

Description	Value
General information:	
Product name:	SBA 3-35 A
Product No:	On request
EAN number:	On request
Price:	
Technical:	
Rated flow:	2.76 m ³ /h
Rated head:	25.2 m
Maximum head:	34 m
Impellers:	3
Max. Particle:	1 mm
Approvals:	CE,VDE,WEEE
Curve tolerance:	ISO9906:2012 3B
Return valve:	YES
Adjustable start pressure:	N
Start pressure:	1.5 bar
Rated driver speed:	2800 rpm
Materials:	
Pump housing:	Composite
Impeller:	Composite
Installation:	
Range of ambient temperature:	-10 .. 50 °C
Type of inlet connection:	STRAINER
Pump outlet:	G 1"
Maximum installation depth:	10 m
Liquid:	
Pumped liquid:	Water
Liquid temperature range:	0 .. 40 °C
Selected liquid temperature:	20 °C
Density:	998.2 kg/m ³
pH-value range:	4-9
Electrical data:	
Power input P1:	0.8 kW
Rated power - P2:	0.54 kW
Mains frequency:	50 Hz
Rated voltage:	1 x 220-240 V
Rated current:	3.8 A
Starting current:	12 A
Cos phi:	0.94
Capacitor size - run:	13 µF/450 V
Enclosure class (IEC 34-5):	IP68
Insulation class (IEC 85):	F
Built-in motor protection:	YES
Length of cable:	15 m
Cable type:	H07RN-F 3G1
Type of cable plug:	SCHUKO
Controls:	
Flow switch:	yes
Others:	
Net weight:	9.42 kg
Gross weight:	10 kg
Shipping volume:	0.022 m ³
Danish VVS No.:	391367035
Swedish RSK No.:	5850417
Finnish LVI No.:	4822596
Norwegian NRF no.:	9041873

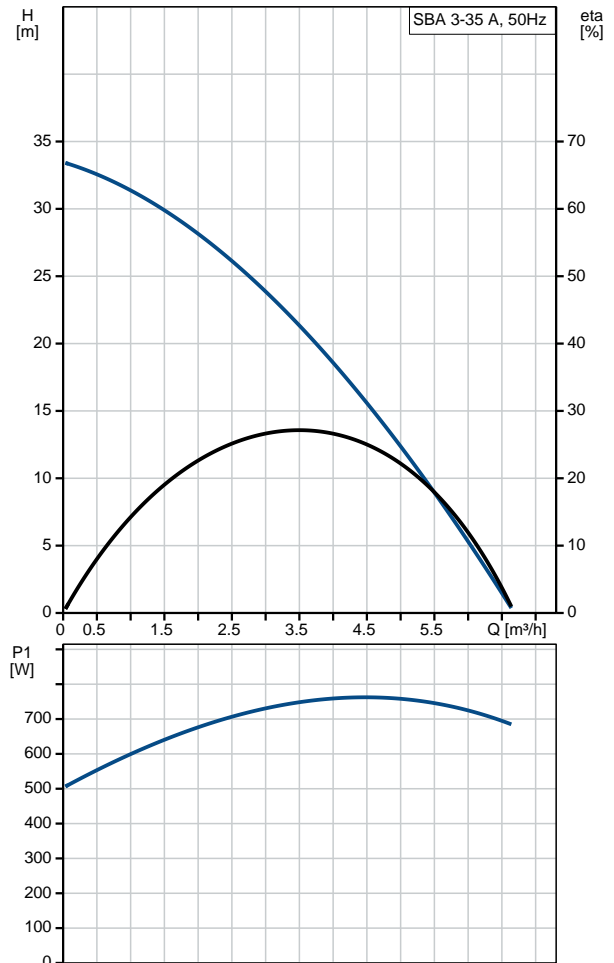

On request SBA 3-35 A 50 Hz

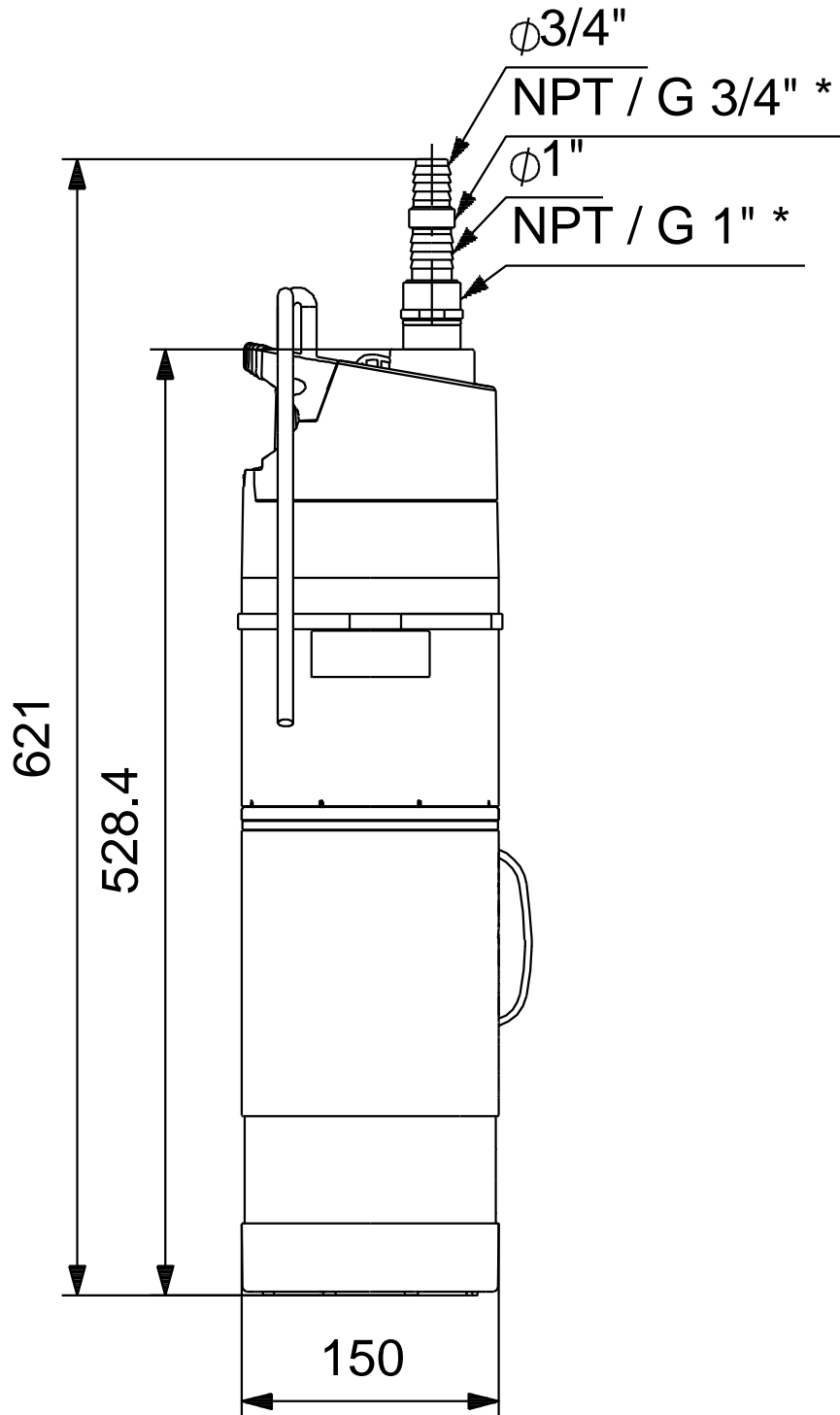

Note! All units are in [mm] unless others are stated.
Disclaimer: This simplified dimensional drawing does not show all details.